



Code	
9828093470	00
Edition 01/2021	

INSTRUCTION AND MAINTENANCE MANUAL

SILENCED SCREW ROTARY COMPRESSOR UNITS

HP 3 - 4 - 5,5 - 7,5 - 10
KW 2,2 - 3 - 4 - 5,5 - 7,5

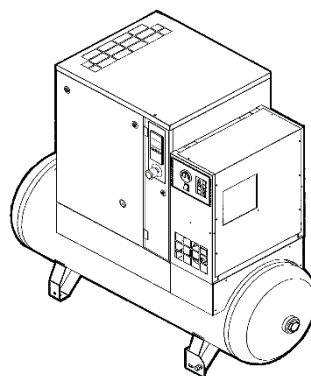

THIS MACHINE MUST BE CONNECTED TO TWO DIFFERENT POWER SUPPLIES: THREE-PHASE OR SINGLE-PHASE SUPPLY FOR THE COMPRESSOR AND SINGLE-PHASE SUPPLY FOR THE DRYER

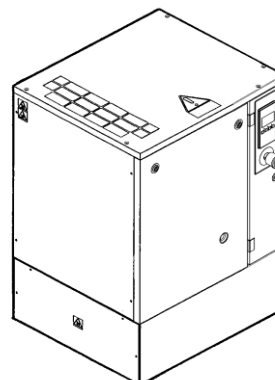
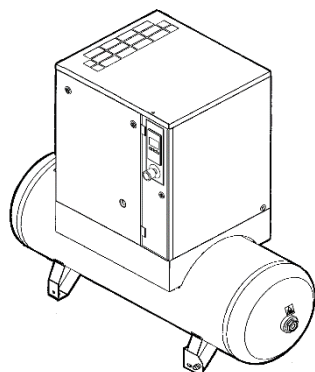

READ THIS MANUAL CAREFULLY BEFORE CARRYING OUT ANY OPERATIONS ON THE COMPRESSOR UNIT.



THIS MACHINE IS DESIGNED FOR BOTH CONTINUOUS AND INTERMITTENT WORKING, HOWEVER TO AVOID CONDENSATION PROBLEMS IN THE OIL, THE MACHINE MUST OPERATE CONTINUOUSLY IN LOAD FOR AT LEAST 10% OF THE TIME, CHECK FOR SIGNS OF CONDENSATION IN THE OIL BY FOLLOWING THE INSTRUCTIONS GIVEN IN CHAPTER 15.2

CONTENTS

PART A: INFORMATION FOR THE USER

- 1.0 GENERAL CHARACTERISTICS
- 2.0 INTENDED USE
- 3.0 OPERATION
- 4.0 GENERAL SAFETY STANDARDS
- 5.0 DESCRIPTION OF DANGER SIGNALS
- 6.0 DANGER ZONES
- 7.0 SAFETY DEVICES
- 8.0 POSITION OF PLATES
- 9.0 COMPRESSOR ROOM
- 10.0 TRANSPORT AND HANDLING
- 11.0 UNPACKING
- 12.0 INSTALLATION
- 13.0 DIMENSIONS AND TECHNICAL DATA
- 14.0 MACHINE ILLUSTRATION
- 15.0 ORDINARY MAINTENANCE TO BE DONE BY THE USER
- 16.0 PERIODS OF INACTIVITY
- 17.0 SCRAPPING THE UNIT
- 18.0 LIST OF SPARE PARTS FOR ROUTINE MAINTENANCE
- 19.0 TROUBLE-SHOOTING AND EMERGENCY REMEDIES

PART B: INFORMATION RESERVED FOR TECHNICALLY SKILLED PERSONNEL

- 20.0 STARTING UP
- 21.0 GENERAL ORDINARY MAINTENANCE REQUIRES TRAINED PERSONNEL
- 22.0 CHANGING THE OIL
- 23.0 CHANGING THE OIL SEPARATING FILTER
- 24.0 BELT TENSION
- 25.0 REPLACING THE BELT
- 26.0 FLOW DIAGRAM
- 27.0 CALIBRATIONS FOR DRYER
- WIRING DIAGRAM (ON THE BACK COVER)

IMPORTANT: A COPY OF THE WIRING DIAGRAMS CAN BE FOUND INSIDE THE ELECTRIC BOARD OF THE COMPRESSOR.

SILENCED SCREW ROTARY COMPRESSOR UNITS

HP 3 - 4 - 5,5 - 7,5 - 10
KW 2,2 - 3 - 4 - 5,5 - 7,5

MACHINE AND MANUFACTURER IDENTIFICATION DATA

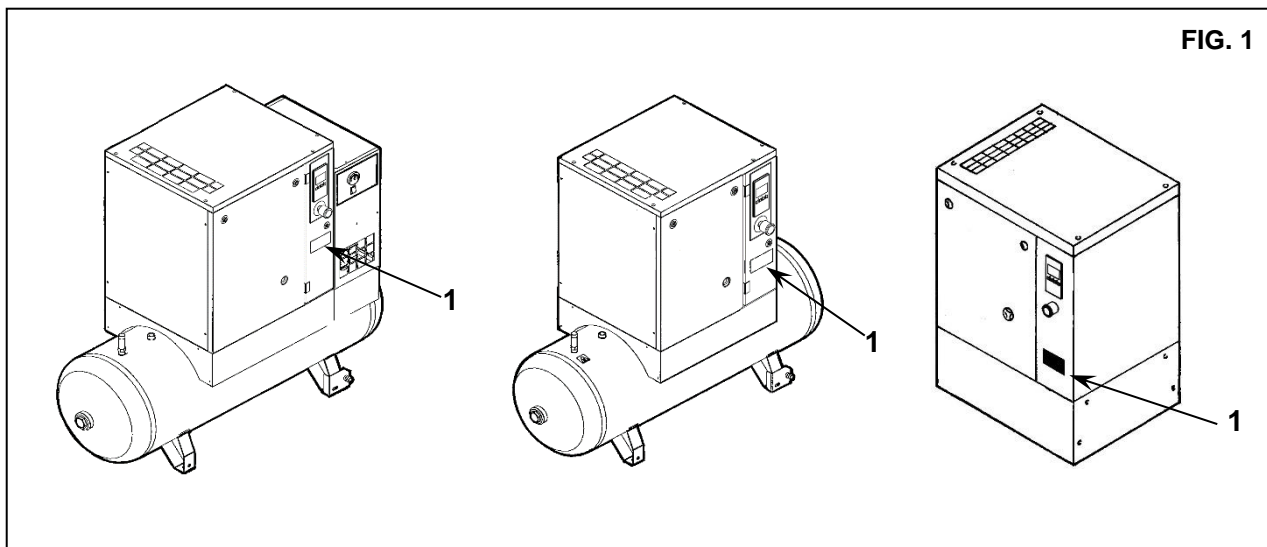

1) Position of the identification plate

ADDRESSES OF ASSISTANCE CENTRES

In the event of breakdown or malfunction of the machine, switch it off and do not tamper with it.
 We remind you that our technical service department is at your complete disposal to help you resolve any problems that may possibly be encountered, or to provide you with any other information necessary.
 The constant and efficient performance of the compressor is ensured only if original spare parts are used.
 We recommend therefore that you strictly observe the indications provided in the MAINTENANCE section and to use EXCLUSIVELY original spare parts.
 The use of NON ORIGINAL spare parts automatically annuls the guarantee.
 Failure to comply with the above may endanger the safety of the machine.

INTRODUCTION

Keep this manual with care for future consultation; the use and maintenance manual is an integral part of the machine. Read this manual carefully before carrying out any operations on the compressor unit.
The installation of the compressor unit and all operations involving it must be performed in conformity with the regulations in force concerning electric plants and personal safety.

CHARACTERISTICS AND SAFETY PRECAUTIONS



MACHINE WITH AUTOMATIC START



BEFORE REMOVING THE PROTECTIVE GUARDS TO CARRY OUT ANY MAINTENANCE ON THE MACHINE, SWITCH OFF THE ELECTRIC POWER SUPPLY AND DISCHARGE THE RESIDUAL PRESSURE INSIDE THE UNIT.

ALL WORK ON THE ELECTRIC PLANT, HOWEVER SLIGHT, MUST BE CARRIED OUT BY PROFESSIONALLY SKILLED PERSONNEL.

THIS MACHINE IS NOT SUITABLE FOR EXTERNAL INSTALLATION

THIS MACHINE CORRESPOND TO THE ESSENTIAL SAFETY REQUIREMENTS FORESEEN FROM THE EUROPEAN STANDARD (2006/42 CE).

THE LUBRICATING LIQUIDS AND OTHER EVENTUAL FLUIDS MUST NOT BE DISCHARGED IN THE ENVIRONMENT. THESE POLLUTING AND HAZARDOUS PRODUCTS MUST COMPULSORY BE DISPOSED BY CHARGING AUTHORISED AND SPECIALISED FIRMS ACCORDING TO THE DIFFERENT TYPOLOGY OF PRODUCT.

DIFFERENTIATE THE COMPRESSOR COMPONENTS ACCORDING TO THE DIFFERENT CONSTRUCTION MATERIALS (PLASTIC, COPPER, IRON, OIL FILTER, AIR FILTER ETC...)

The manufacturer does not accept responsibility for damage caused as a result of negligence or failure to abide by the instructions given above.

AIR RECEIVER AND SAFETY VALVE:

- To limit internal corrosion, which could compromise the safety of the compressed air tank, **the condensation that is produced must be discharged at least once a day.** If an automatic drain fitted to the air receiver is present, it is necessary to check that it is working correctly every week and repair it if necessary.
- **The thickness of the receiver must be checked every year and also in accordance with legislation in force in the country where the receiver is installed.**
- **The tank cannot be used and must be replaced if the thickness falls below the minimum level given in the instruction documents for the tank.**
- The tank can be used within the temperature limits given in the conformity declaration.
- **The safety valves of the air receiver and oil receiver must be checked every year and replaced in accordance with legislation in force.**

NOT RESPECTING THE ABOVE MENTIONED PRESCRIPTION CAN RESULT IN AIR RECEIVER BURSTING HAZARD.

The manufacturer does not accept responsibility for damage caused as a result of negligence or failure to abide by the instructions given above.

1.0 GENERAL CHARACTERISTICS

The compressor units use single-stage screw rotary air compressors with oil injection.
 The system is self-bearing and does not require bolts or other devices to anchor it to the floor.
 The unit is completely assembled in the factory; the necessary connections for setting it up are:

- connection to the power mains (see installation chapter)
- connection to the compressed air network (see installation chapter)

2.0 INTENDED USE

The compressor has been built to supply compressed air for industrial use. The machine cannot be used in premises where there is a risk of fire or explosion, or where the activity performed can release into the environment dangerous substances (for example: solvents, inflammable vapours, alcohol, etc.). In particular the appliance cannot be used to produce air to be breathed by humans or used on direct contact with foodstuffs. These uses are allowed if the compressed air produced is filtered by means of a suitable filtering system (Consult the manufacturer for these special uses.) This appliance must be used only for the purpose for which it was specifically designed. All other uses are to be considered incorrect and therefore unreasonable. The Manufacturer cannot be held responsible for any damage resulting from improper, incorrect or unreasonable use.

3.0 OPERATION

3.1 OPERATION FOR COMPRESSOR

The electric motor and the compressor unit are coupled by means of a belt transmission. The compressor unit takes in the outside air through the suction valve. The intake air is filtered by the filter cartridge fitted upstream from the intake valve. Inside the compressor unit, the air and the lubricating oil are compressed and sent to the oil separating tank where the oil is separated from the compressed air; the air is then filtered again by the oil separating cartridge to reduce the amount of suspended oil particles to a minimum. The machine is fitted with a suitable air-cooling system. The machine is protected by a special safety thermostat: if the oil temperature reaches 120°C the machine cuts out automatically.

3.2 OPERATION FOR DRYER

At the moment of use the air flows from the tank to the drier and is then dried and sent to the distribution network. Dryer operation is described below. The gaseous refrigerant coming from the evaporator (4) is sucked by the refrigeration compressor (1) and it is pumped into the condenser (2). This one allows its condensation, eventually with the help of the fan (3); the condensed refrigerant passes through the dewatering filter (8) and it expands through the capillary tube (7) and goes back to the evaporator where it produces the refrigerating effect. Due to the heat exchange with the compressed air which passes through the evaporator against the stream, the refrigerant evaporates and goes back to the compressor for a new cycle. The circuit is equipped with a bypass system for the refrigerant; this intervenes to adjust the available refrigerating capacity to the actual cooling load. This is achieved by injecting hot gas under the control of the valve (9): this valve keeps constant the pressure of the refrigerant in the evaporator and therefore also the dew point never decreases below 0 °C in order to prevent the condensate from freezing inside the evaporator. The drier runs completely automatically; it is calibrated in the factory for a dew point of ~ 3 °C and therefore no further calibrations are required.

DRYER FLOW DIAGRAM

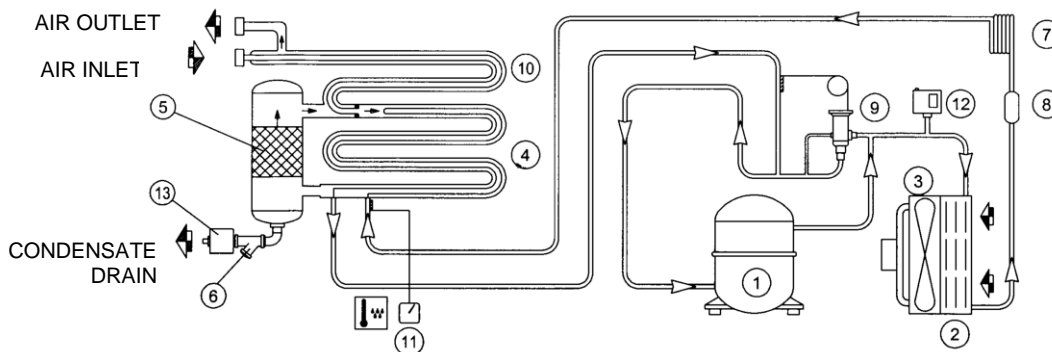

4.0 GENERAL SAFETY STANDARDS

The appliance may be used only by specially trained and authorized personnel. Any tampering with the machine or alterations not approved beforehand by the Manufacturer relieve the latter of responsibility for any damage resulting from the above actions. The removal of or tampering with the safety devices constitutes a violation of the European Standards on safety.











ATTENTION: UPSTREAM OF THE MACHINE INSTALL AN ISOLATOR KNIFE-SWITCH WITH AN AUTOMATIC CUTOUT AGAINST CURRENT SURGES AND EQUIPPED WITH A DIFFERENTIAL DEVICE.



ALL WORK ON THE ELECTRIC PLANT, HOWEVER SLIGHT, MUST BE CARRIED OUT BY PROFESSIONALLY SKILLED PERSONEL.

5.0 DESCRIPTION OF DANGER SIGNALS

FIG. 2

	1) FLUID EJECTION		6) HIGH PRESSURE
	2) DANGEROUS ELECTRIC VOLTAGE		7) HOT PARTS
	3) AIR NOT FIT FOR BREATHING		8) MOVING PARTS
	4) NOISE		9) FAN ROTATING
	5) MACHINE WITH AUTOMATIC START		10) PURGE EVERY DAY

5.1 DESCRIPTION OF COMPULSORY SIGNALS

	11) READ THE USE AND MAINTENANCE INSTRUCTIONS		
---	---	--	--

6.0 DANGERS ZONES

6.1 DANGERS ZONES FOR COMPRESSOR UNIT (FIG. 3)

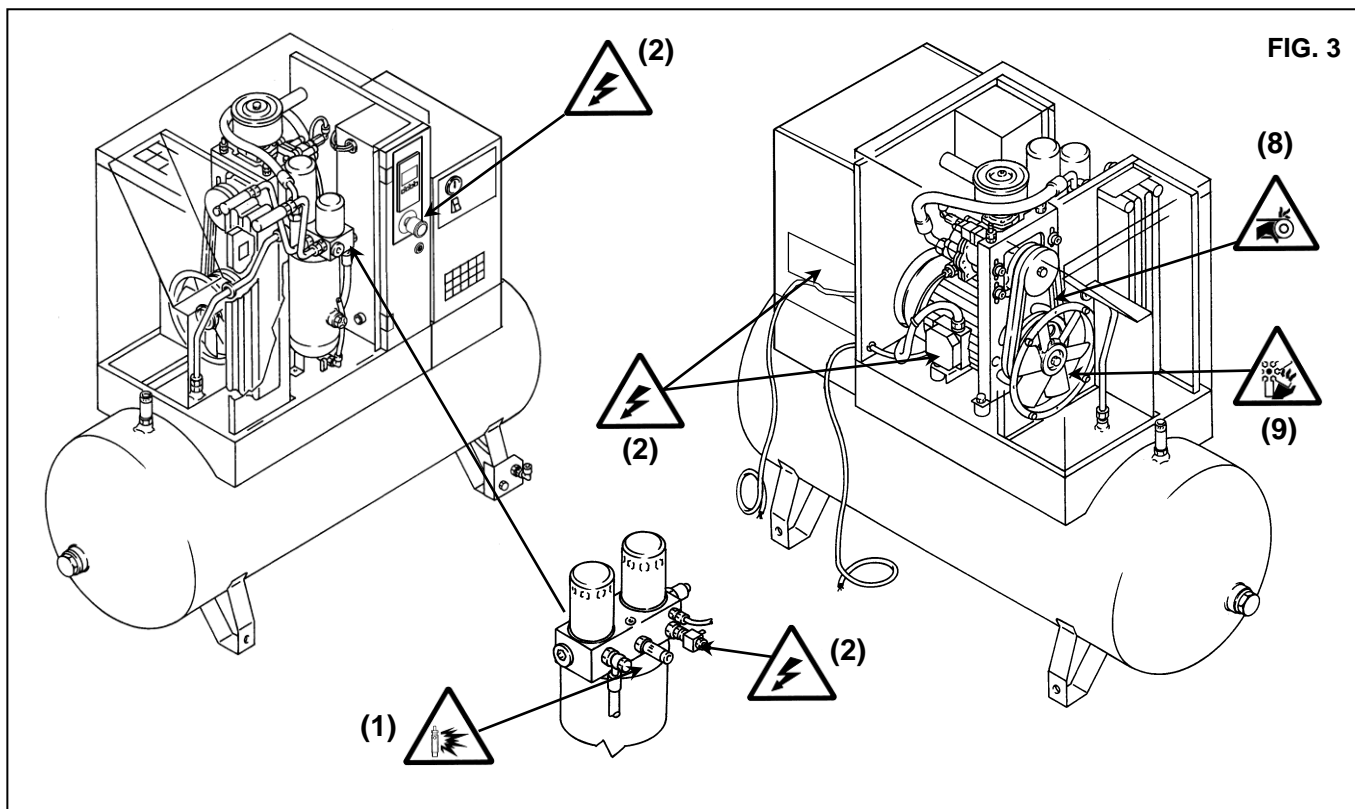
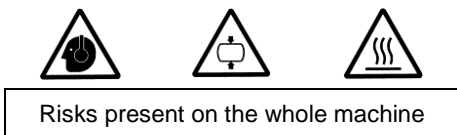

6.2 DANGERS ZONES FOR DRIER UNIT AND TANK (FIG.4)



Risks present on the whole machine

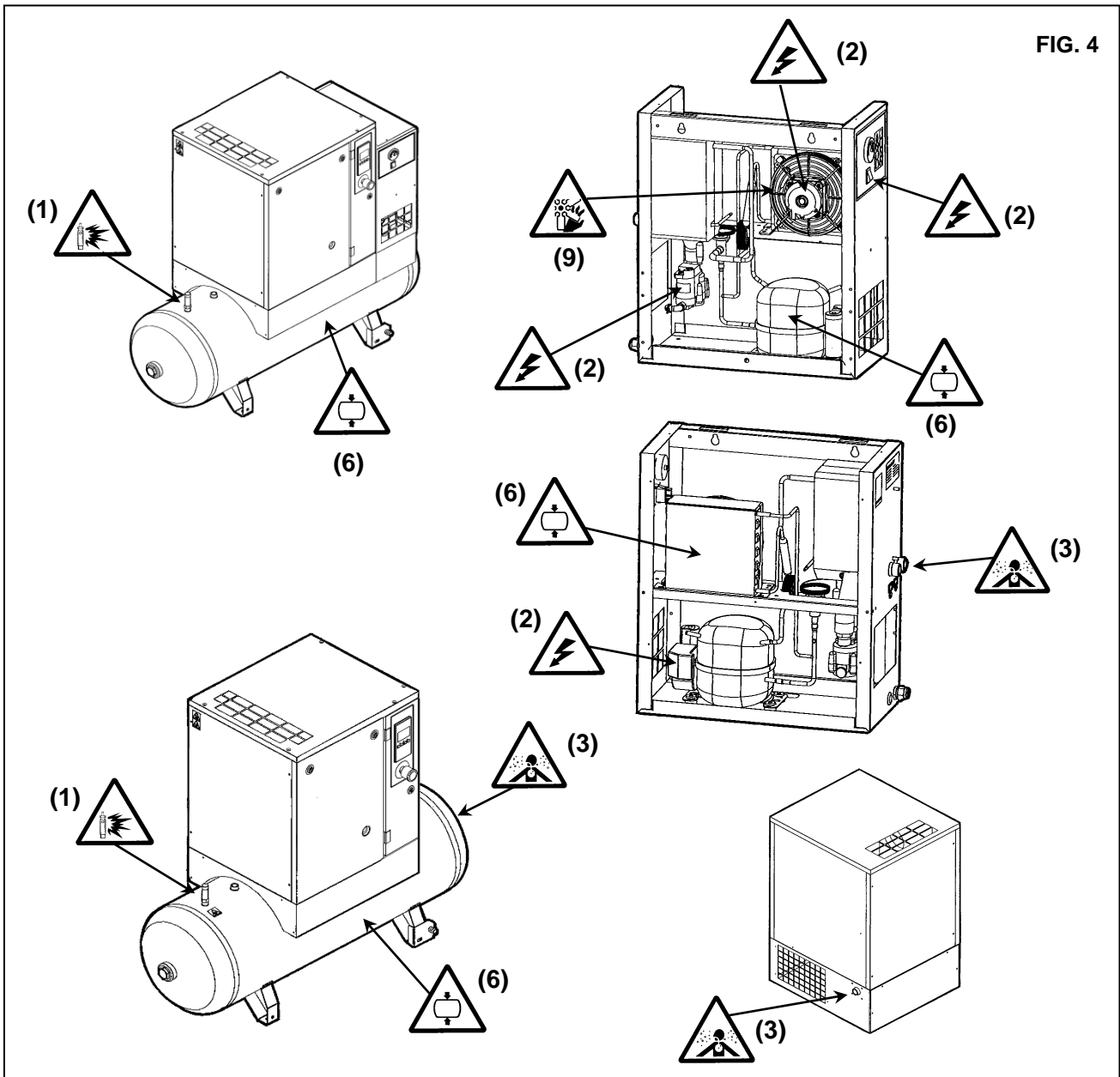
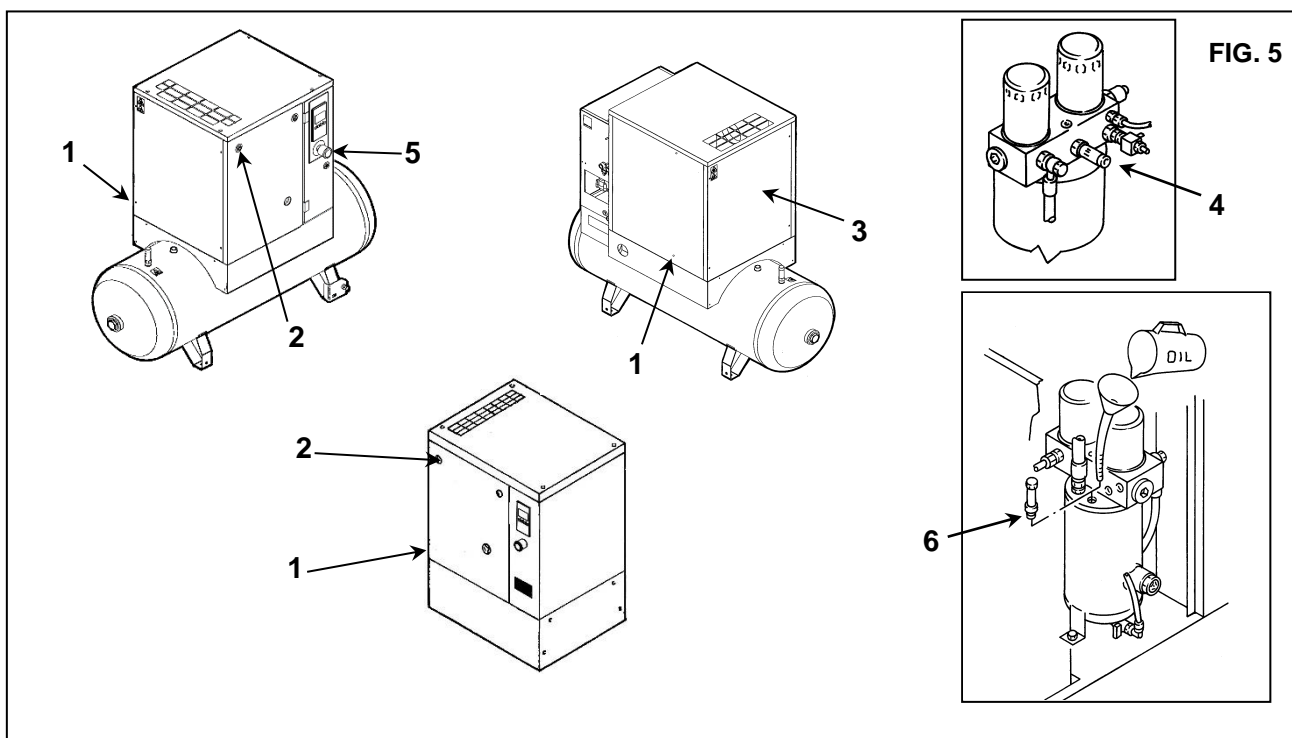

FIG. 4

7.0 SAFETY DEVICES

7.1 SAFETY DEVICES FOR SCREW COMPRESSOR (FIG. 5)

- 1) Safety screws
- 2) The front protection can be opened with a special key
- 3) Fixed protection device - cooling fan / pulley
- 4) Safety valve
- 5) Emergency stop
- 6) Oil filling cap (with safety breather)



7.2 SAFETY DEVICES FOR DRYER UNIT AND TANK (FIG.6)

- 1) Safety valve
- 2) Protective switch cap.
- 3) Relay for compressor (automatic)
- 4) Overload protector for compressor

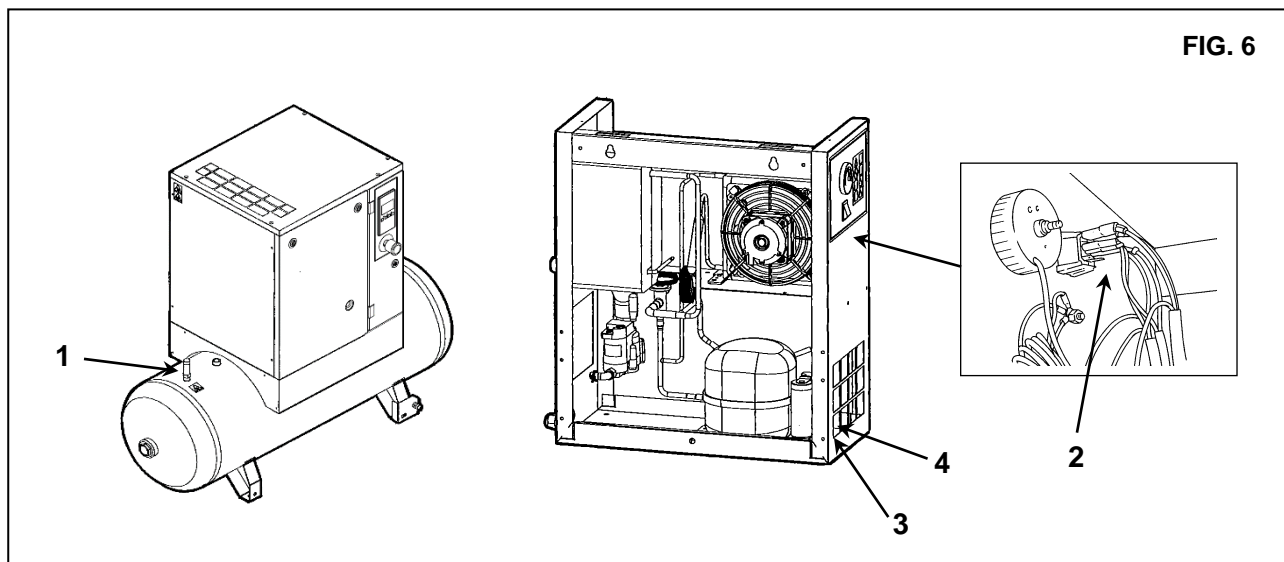

8.0 POSITION OF PLATES

8.1 POSITION OF THE DANGER PLATES FOR COMPRESSOR UNIT (FIG.7)

The plates fitted on the compressor unit are part of the machine; they have been applied for safety purposes and must not be removed or spoiled for any reason.

- 1) Dangers plate Code 2202 2607 90
- 2) Plate "Machine with automatic start" Code 2202 2510 89

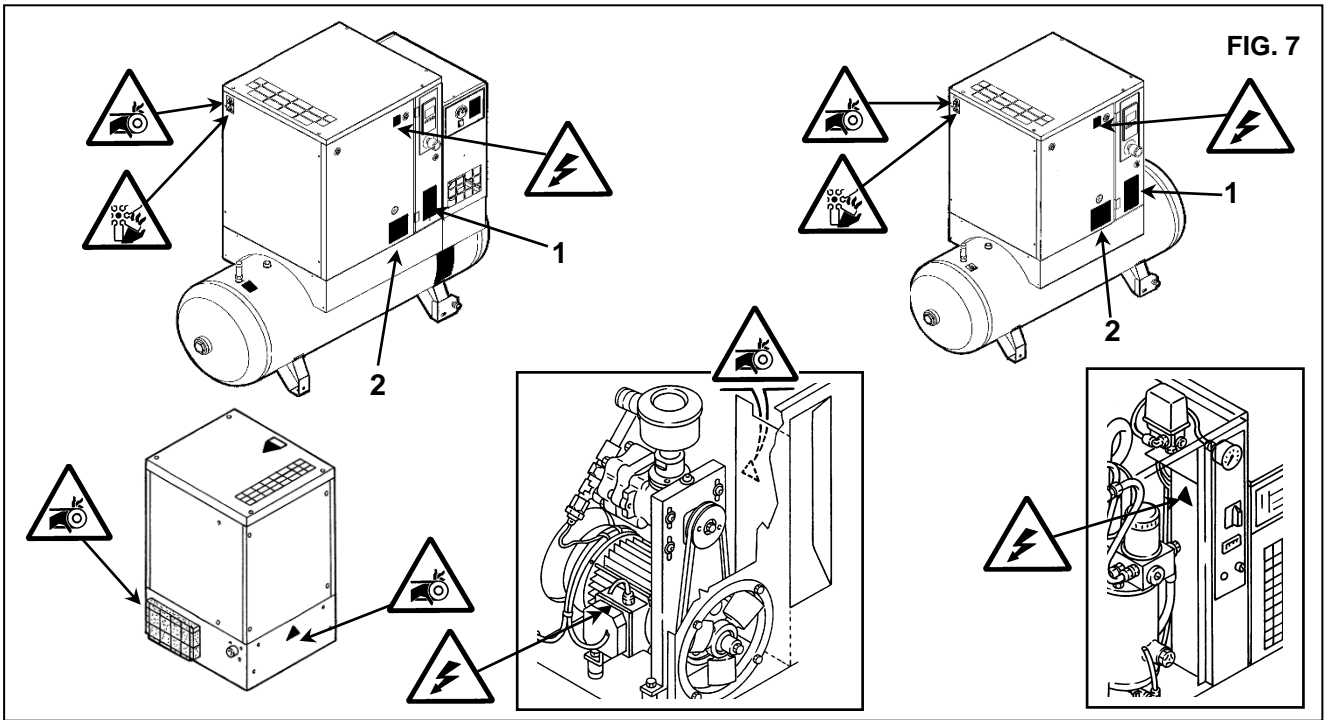

8.2 POSITION OF THE DANGER PLATES FOR DRYER UNIT AND TANK (FIG.8)

The plates fitted on the compressor unit are part of the machine; they have been applied for safety purposes and must not be removed or spoiled for any reason.

- 1) Dangers plate 1079 9926 55

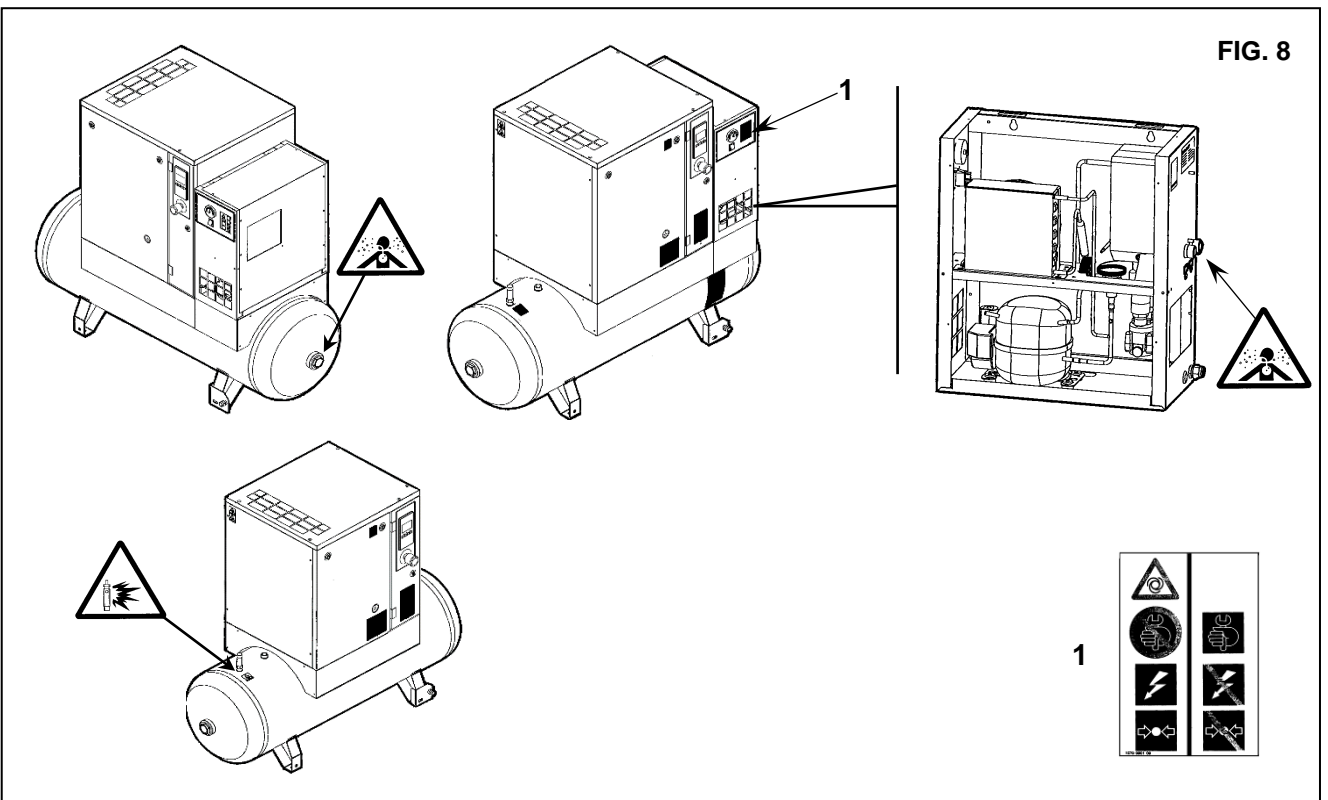

8.3 POSITION OF THE DATA PLATE FOR COMPRESSOR UNIT (FIG.9)

FIG. 9

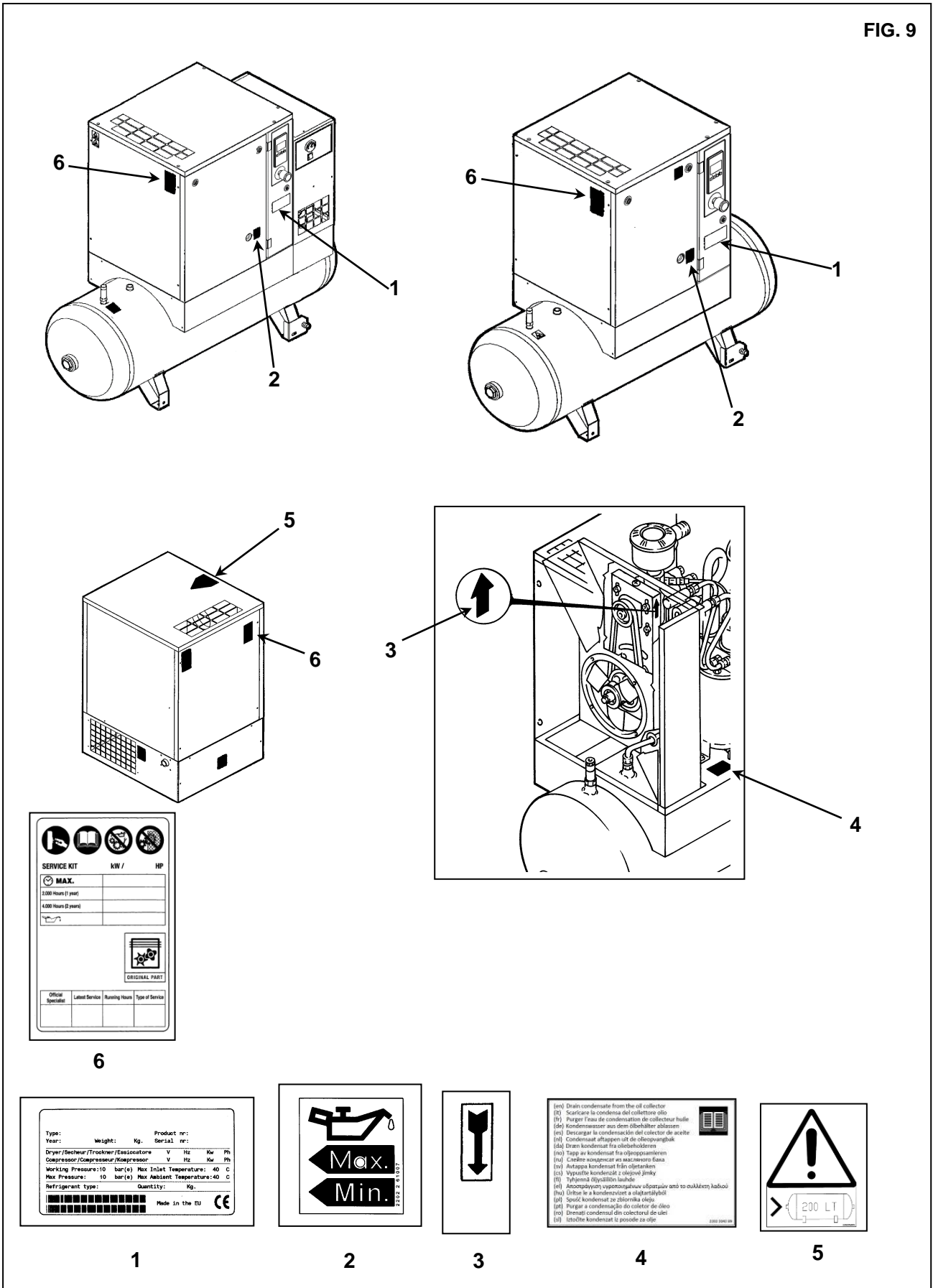

8.4 POSITION OF THE DATA PLATE FOR DRYER – AIR RECEIVER (FIG. 10)

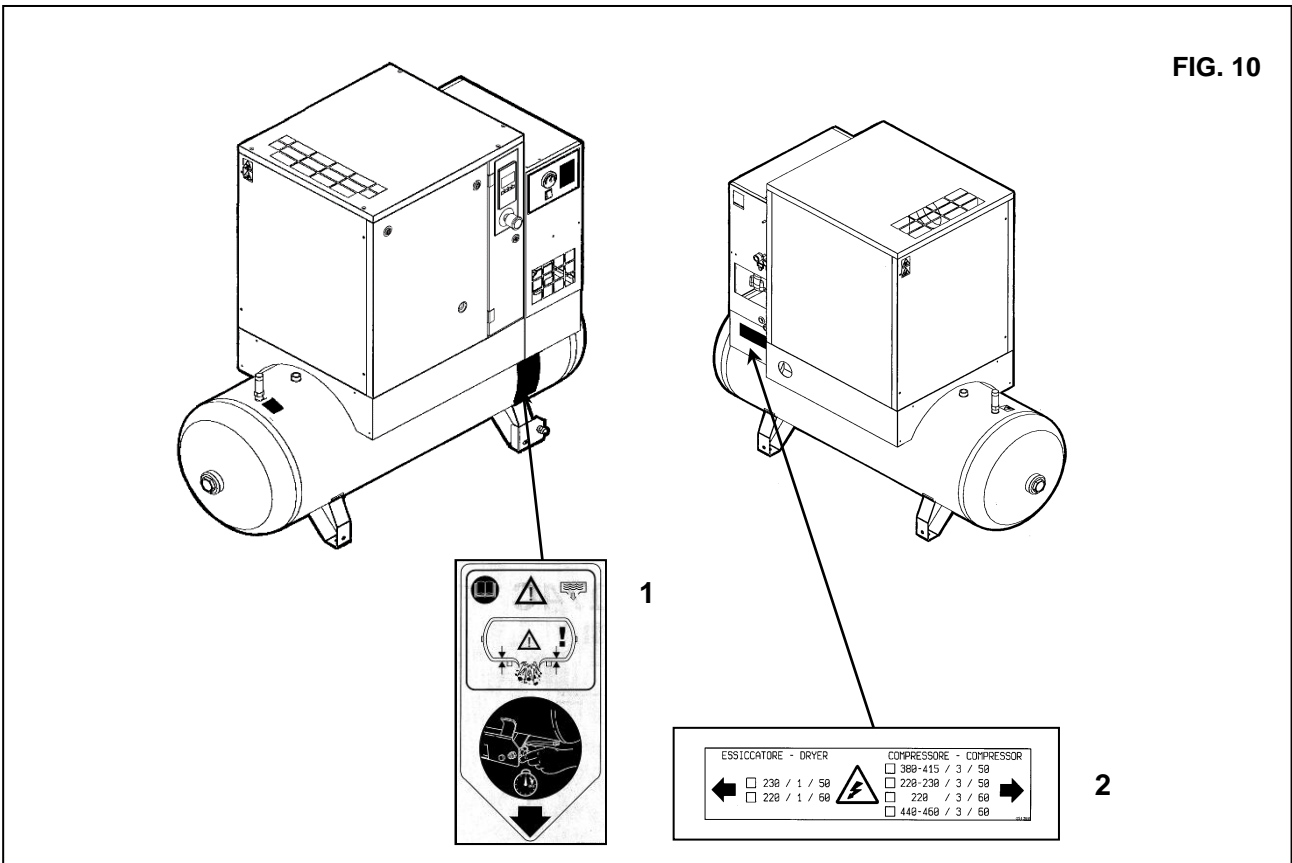

9.0 COMPRESSOR ROOM

9.1 FLOOR

The floor must be even and of industrial type; the total weight of the machine is shown in the Chap. 13.0 Remember the total weight of the machine when positioning it.

9.2 VENTILATION

When the machine is operating, the room temperature must not be higher than **46 °C** or lower than **5 °C**.

The volume of the room must be about **30 m³**

The room must be provided with 2 openings for ventilation with a surface area of about **0,5 m²** each.

The first opening must be in a high position to evacuate the hot air, the second opening must be low to allow the intake of external air for ventilation.

If the environment is dusty it is advisable to fit a filtering panel on this opening.

9.3 EXAMPLES OF VENTILATION OF THE COMPRESSOR ROOM (FIG.11)

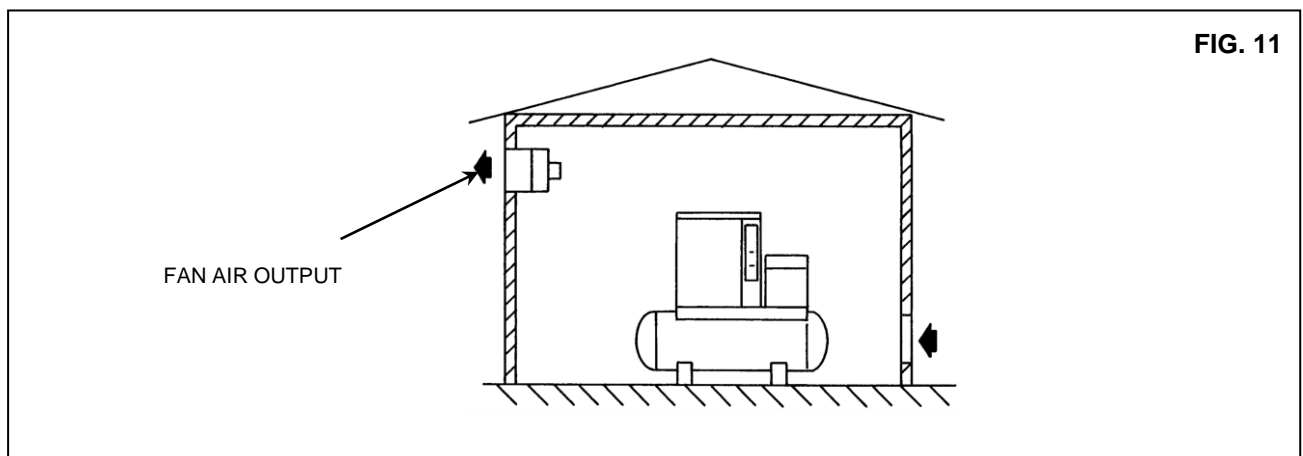

10.0 TRANSPORT AND HANDLING (FIG.12)

The machine must be transported as shown in the following figures.

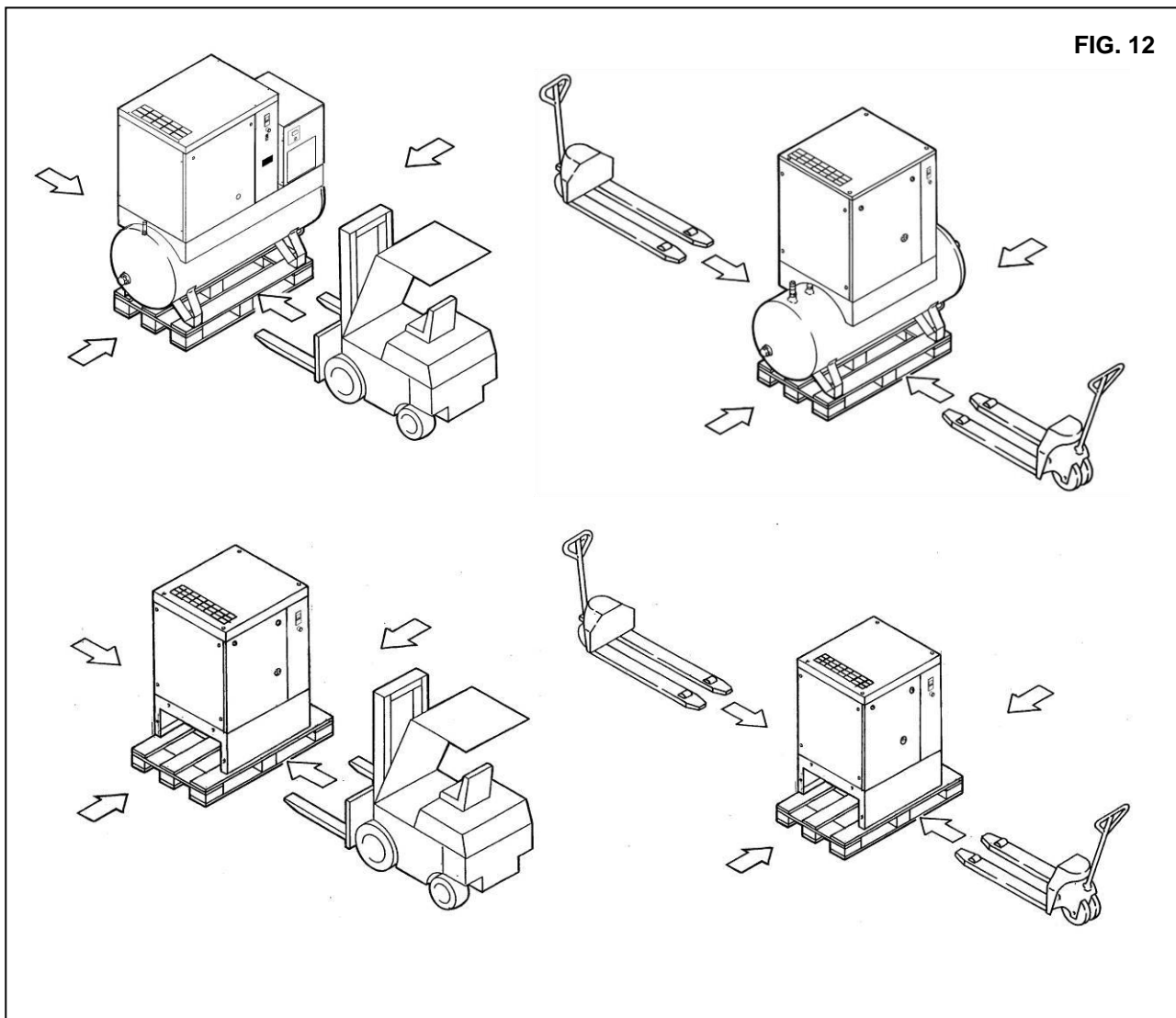
**11.0 UNPACKING**

After removing the packing, ensure that the machine is unbroken and that there are no visibly damaged parts. If you are in doubt, do not use the machine but apply to the manufacturer technical assistance service or to your dealer. The packing material (plastic bags, polystyrene foam, nails, screws, wood, metal strapping, etc..) must not be left within the reach of children or abandoned in the environment, as they are a potential source of danger and pollution. Dispose of these materials in the approved collection centres.

12.0 INSTALLATION

12.1 POSITIONING

After unpacking the equipment and preparing the compressor room, put the machine into position, checking the following items:

- Ensure that there is sufficient space around the machine to allow maintenance (see FIG. 13).
- Check that the compressor is standing on a perfectly flat floor.

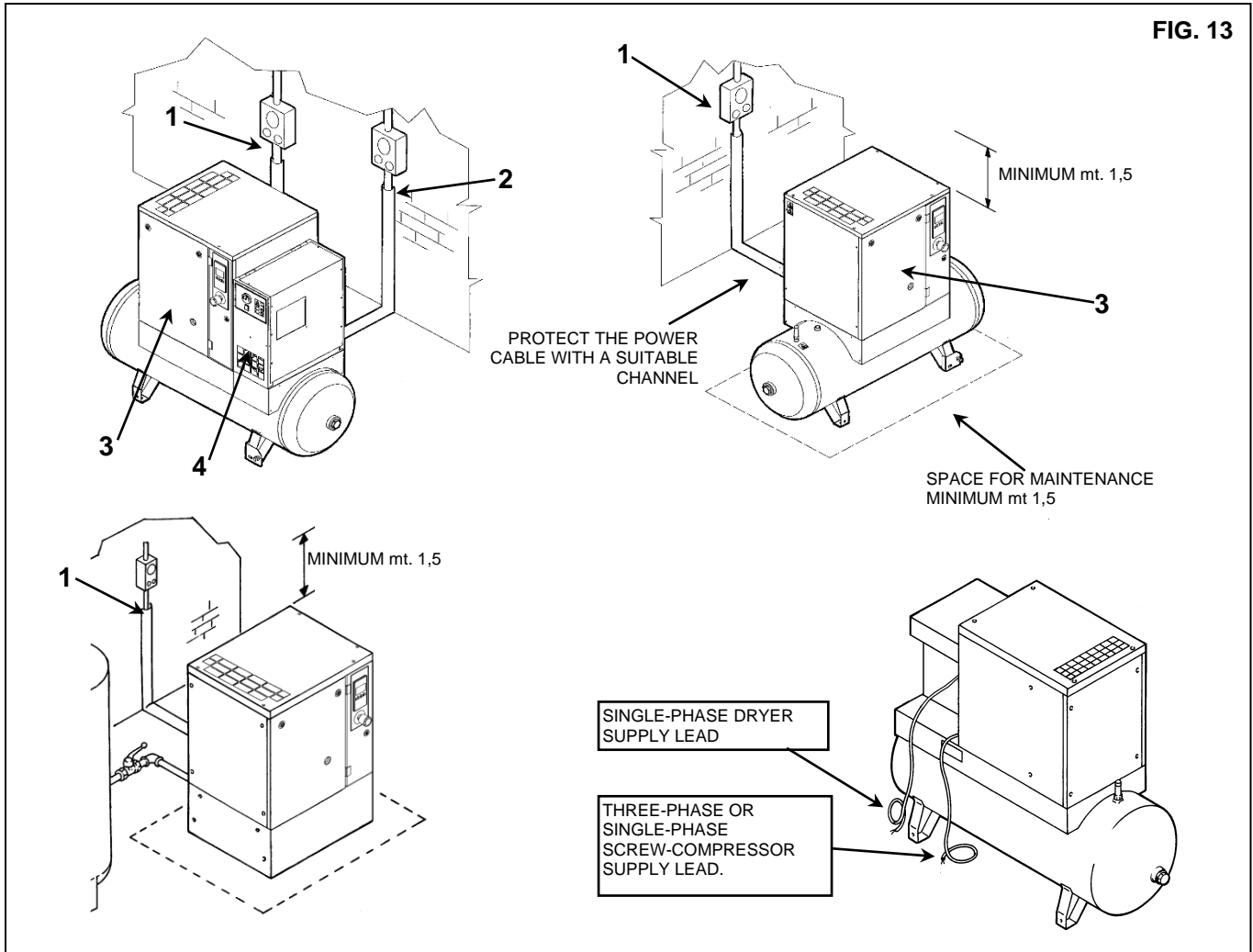

FIG. 13



ENSURE THAT THE OPERATOR CAN SEE THE WHOLE MACHINE FROM THE CONTROL PANEL AND CHECK THE PRESENCE OF ANY UNAUTHORIZED PERSONS IN THE PROXIMITY OF THE MACHINE.

12.2 ELECTRICAL CONNECTION

- Check that the supply voltage is the same as the value indicated on the machine data plate.
CAUTION: the compressor Ref. 3 and the dryer Ref. 4 have two separate supply, respectively three-phase or single-phase and single-phase.
- Check the condition of the line leads and ensure that there is an efficient earth lead.
- Ensure that there is an automatic cut-out device upstream for the machine against overcurrents, with a differential device (see Ref. 1 for compresseur Ref. 2 for dryer) wiring diagram.
- Connect the machine power cables with the greatest care, according to the standards in force. These cables must be as indicated on the machine wiring diagram.



ONLY PROFESSIONALLY SKILLED PERSONNEL MAY HAVE ACCESS TO THE ELECTRIC PANEL. SWITCH OFF THE POWER BEFORE OPENING THE DOOR OF THE ELECTRIC PANEL.

COMPLIANCE WITH THE REGULATIONS IN FORCE CONCERNING ELECTRIC PLANTS IS FUNDAMENTAL FOR OPERATOR SAFETY AND FOR THE PROTECTION OF THE MACHINE.

CABLES, PLUGS AND ALL OTHER TYPE OF ELECTRIC MATERIAL USED FOR THE CONNECTION MUST BE SUITABLE FOR THE USE AND COMPLYING WITH THE REQUIREMENTS STATED BY THE REGULATIONS IN FORCE.

12.3 CONNECTION TO THE COMPRESSED AIR NETWORK

Fit a manual interception valve Ref. 1 between the machine and the compressed air network so that the compressor may be isolated during maintenance operations; (see figure 14).



PIPES, FITTINGS AND CONNECTIONS USED FOR THE CONNECTION OF THE ELECTROCOMPRESSOR TO THE COMPRESSED AIR NETWORK MUST BE SUITABLE TO THE USE ACCORDING TO THE PRESCRIPTIONS OF THE REGULATIONS IN FORCE IN THE COUNTRY OF USE.

ALL DAMAGE DUE TO THE FAILURE TO COMPLY WITH THESE INDICATIONS CANNOT BE ATTRIBUTED TO THE MANUFACTURER AND MAY CAUSE INVALIDITY OF THE GUARANTEE CONDITIONS.

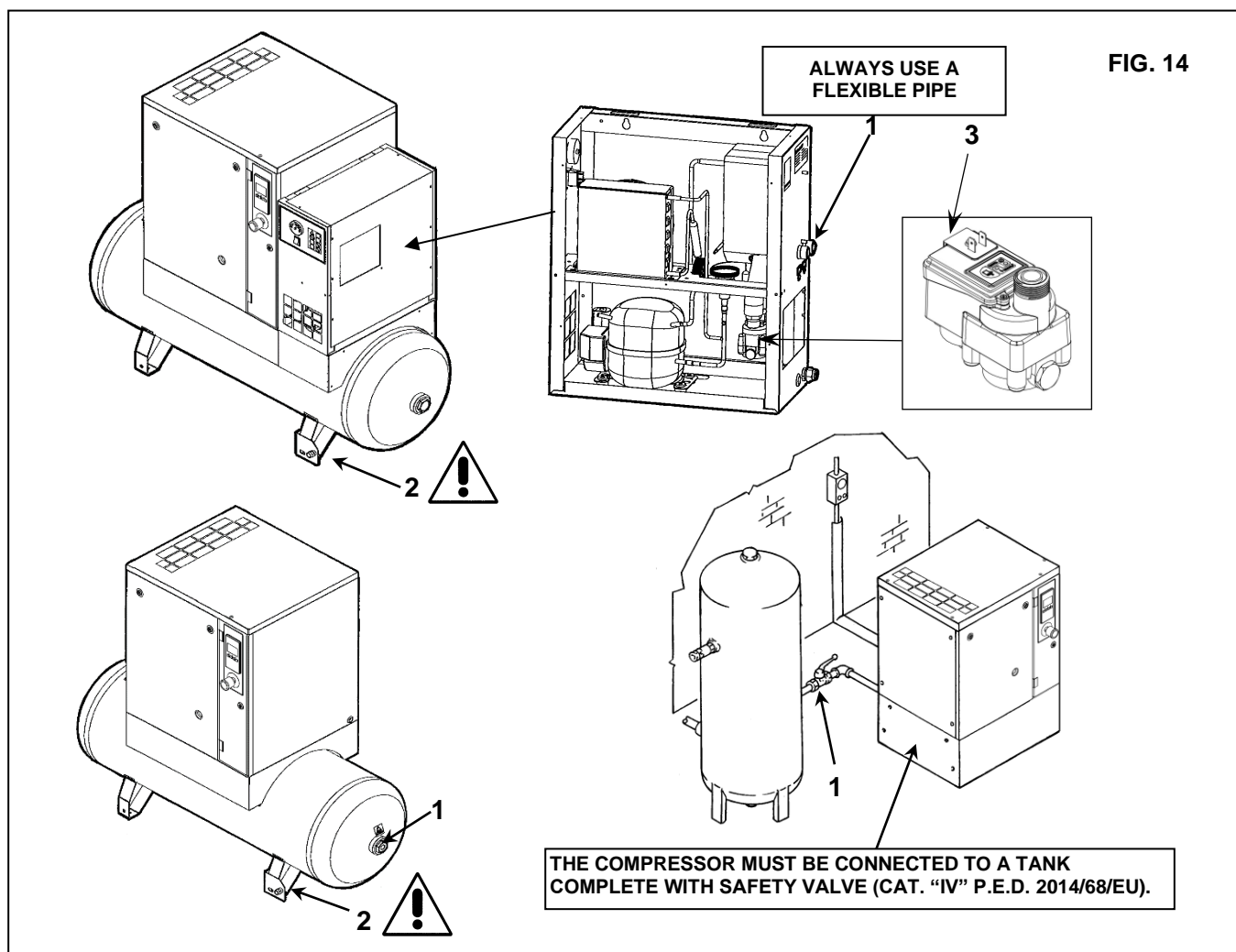

The manual drainage Ref. 2 Fig. 14 the condensate automatic Ref. 3 Fig. 14, are led outside the machine with a flexible pipe that may be inspected. Drainage must comply with the local regulations in force.



ALL DAMAGE DUE TO THE FAILURE TO COMPLY WITH THESE INDICATIONS CANNOT BE ATTRIBUTED TO THE MANUFACTURER AND MAY CAUSE INVALIDITY OF THE GUARANTEE CONDITIONS.

12.4 STARTING UP

See part B of this manual, **Chapter 20.0**

13.0 DIMENSIONS AND TECHNICAL DATA

air receiver 200 Liters

on base

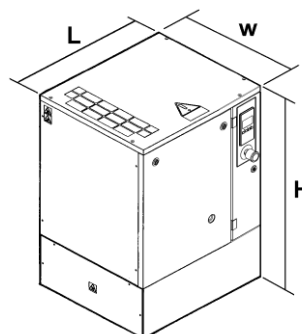
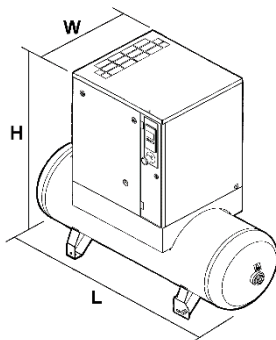
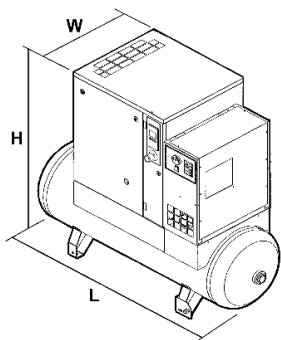

HP 3-4-5,5-7,5-10 KW 2,2-3-4-5,5-7,5	Dimensions mm (inch)				
	L	W (1)	W (2)	H	air connection
On base frame	620 (24,4)	630 (24,8)	665 (26,2)	950 (37,4)	3/4"
Air Receiver 200L	1430 (56,3)	600 (23,6)	665 (26,2)	1260 (49,6)	1/2"
Air Receiver 270L	1540 (60,6)	600 (23,6)	665 (26,2)	1350 (53,1)	1/2"
Air Receiver 500L	1950 (76,8)	600 (23,6)	665 (26,2)	1500 (59,1)	1/2"

W (1) = standard canopy
W (2) = all power V230/1/60Hz ; 7,5HP(5,5kW) 60Hz ; 10HP(7,5kW) 50-60Hz

	HP 3 kW 2,2		HP 4 kW 3		HP 5,5 kW 4		HP 7,5 kW 5,5		HP 10 kW 7,5	
Setting pressure bar(e)	8	10	8	10	8	10	8	10	8	10
Free air delivery l/min.	366	294	474	366	600	516	888	780	1062	984
Approx. weight (no dryer, 200L air receiver) Kg (lb)	165 (364)		170 (375)		175 (386)		185 (408)		195 (430)	
Approx. weight (with dryer, 200L air receiver) Kg (lb)	190 (419)		195 (430)		200 (441)		210 (463)		225 (496)	
Approx. weight (on base frame) Kg (lb)	110 (243)		115 (254)		120 (265)		130 (287)		140 (309)	
Setting controller °C (°F)	110 ÷ 115 (230 ÷ 239)									
Oil capacity L (gal)	~ 2,5 (0,66)						~ 3,2 (0,83)			

The weight above refers to the standard unit IEC V400 / 3 / 50Hz, PED (CE) approval.
The weight may vary according to the voltage variant and approval of the pressure equipment.
Weight air receiver 270L : add 35kg (77lb)
Weight air receiver 500L : add 60kg (133lb)

HP (kW)	Dryer type	Weight Kg. (lb)	Freon R-513A Kg. (lb)			Nominal power W (HP)			Nominal power W (HP)			Nominal power W (HP)			bar (psi) MAX.
			230/50Hz	230/60Hz	115/60Hz	230/50Hz	230/60Hz	115/60Hz	230/50Hz	230/60Hz	115/60Hz	230/50Hz	230/60Hz	115/60Hz	
3-4-5,5 (2,2-3-4)	A1	19 (41,9)	0,170 (0,37)	0,170 (0,37)	0,180 (0,40)	135 (0,18)	125 (0,168)	121 (0,162)	29 (0,038)	42 (0,056)	38 (0,051)	164 (0,220)	167 (0,224)	159 (0,213)	16 (232)
7,5 (5,5)	A2	20 (44,1)	0,290 (0,64)	0,290 (0,64)	0,290 (0,64)	161 (0,22)	173 (0,232)	148 (0,198)	29 (0,038)	49 (0,066)	45 (0,060)	190 (0,255)	222 (0,298)	193 (0,259)	16 (232)
10 (7,5)	A3	25 (55,1)	0,350 (0,77)	0,350 (0,77)	0,350 (0,77)	233 (0,31)	252 (0,338)	251 (0,337)	33 (0,044)	54 (0,072)	50 (0,067)	266 (0,356)	306 (0,410)	301 (0,404)	16 (232)

Reference conditions:
Ambient temperature 25 °C (77 °F)
Inlet air temperature 35 °C (95 °F)
Pressure 7 bar (102 psi)
Dew point in pressure 5 °C (41 °F)

Limit conditions:
Max. ambient temperature 45 °C (113 °F)
Min. ambient temperature 5 °C (41 °F)
Max. inlet air temperature 55 °C (131 °F)
Max. working pressure 16 bar (232 psi)

14.0 MACHINE ILLUSTRATION

14.1 GENERAL LAY-OUT FOR DRYER AND TANK (FIG.15)

- 1 Refrigerant compressor
- 2 Condenser
- 3 Motor fan
- 4 Evaporator
- 5 Condensate drain solenoid valve
- 6 Hot gas bypass valve
- 7 Refrigerant filter
- 8 Expansion capillary tube
- 9 Safety valve (Compressed air tank) *
- 10 Compressed air tank
- 11 Condensate manual drainage

*** IT IS FORBIDDEN TO TAMPER WITH THE SETTING VALUES OF THE SAFETY VALVE**

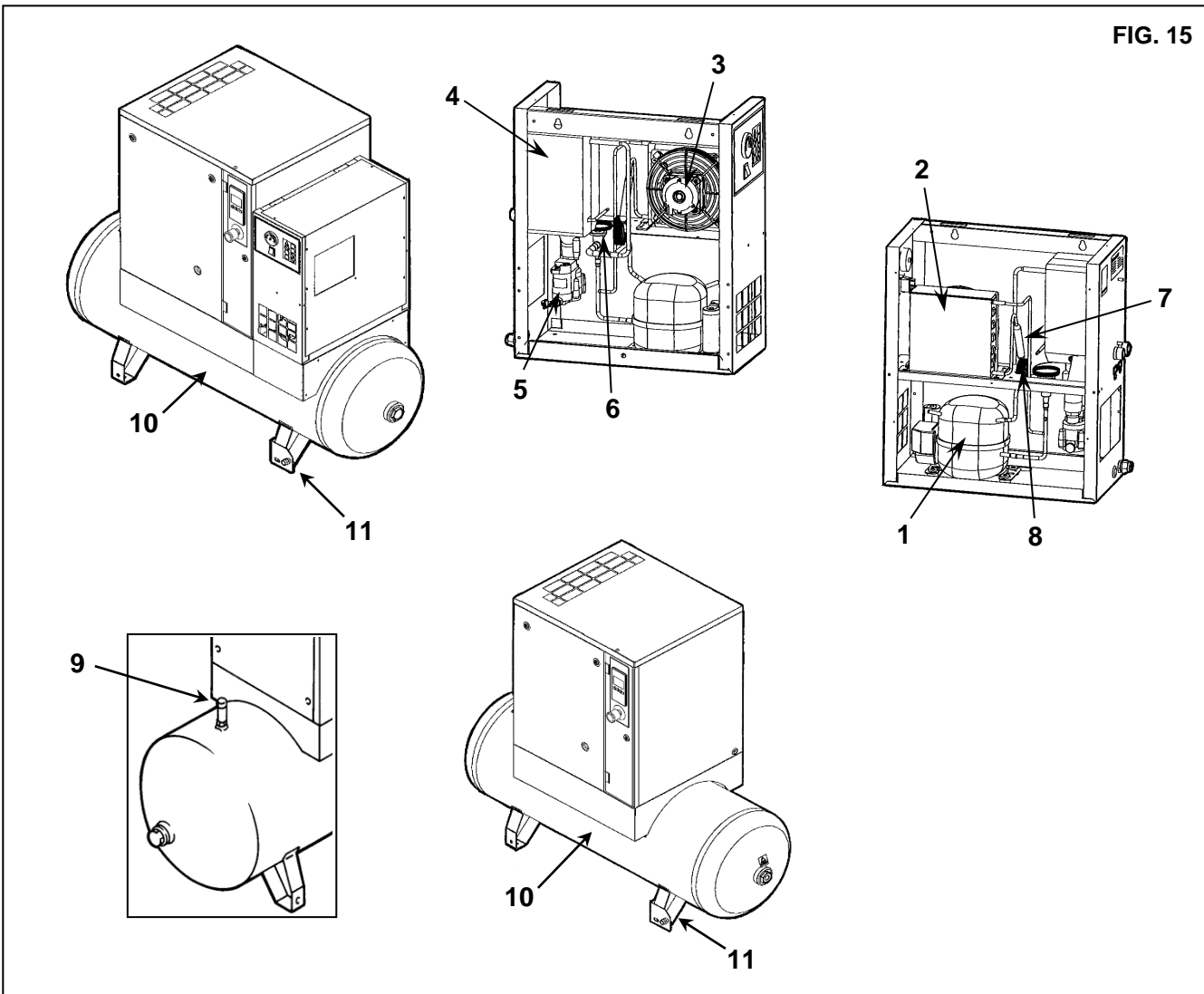

14.2 GENERAL LAY-OUT FOR SCREW COMPRESSOR (FIG.16)

- | | |
|--|--------------------------------------|
| 1 Air suction filter | 12 Oil discharge |
| 2 Thermostatic valve | 13 Oil tank |
| 3 Oil filter | 14 Pressure sensor (Base Controller) |
| 4 No-load running solenoid valve (HP 7,5-10 / kW 5,5-7,5) ** | 15 Safety valve * |
| 5 Blow off solenoid valve (HP 3-4-5,5 / kW 2,2-3-4) | 16 Electric motor |
| 6 Belt tightening system | 17 Screw compressor |
| 7 Minimum pressure valve | 18 Suction unit |
| 8 Air-oil separator filter | 19 Oil cooler |
| 9 Top-up or oil filling cap | |
| 10 Control panel | |
| 11 Oil gauge | |

*** IT IS FORBIDDEN TO TAMPER WITH THE SETTING VALUES OF THE SAFETY VALVE**

** 5,5 / kW 4 1ph 60Hz machines are equipped with unloader

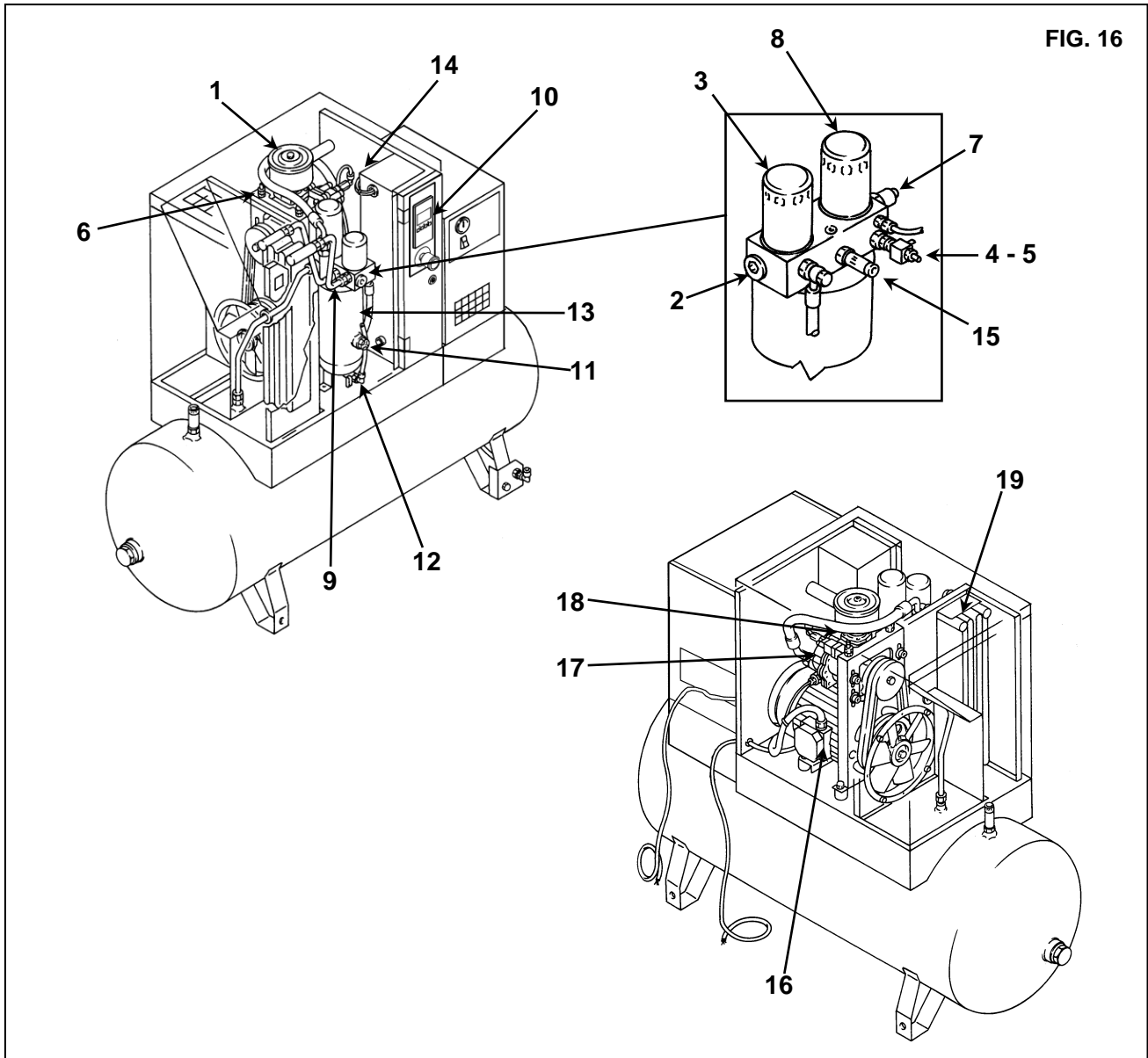
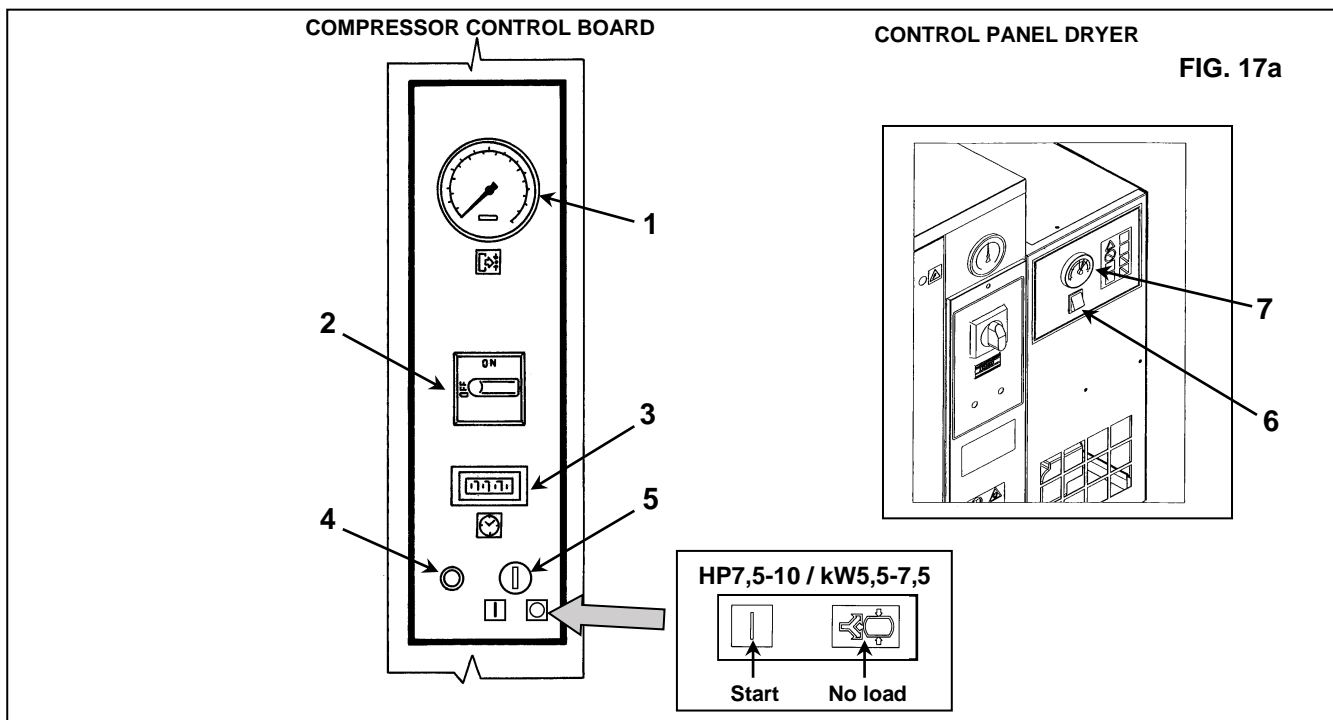

FIG. 16

14.3 COMMAND AND CONTROL PANEL (ELECTRO PNEUMATIC VERSION) (FIG.17a)



BEFORE CARRYING OUT THE OPERATION TEST, READ CAREFULLY AND GET A GOOD KNOWLEDGE OF THE CONTROL FUNCTIONS.



- 1) Pressure gauge – air delivery
- 2) Compressor's isolating switch - **also used as emergency stop and for resetting the motor thermal protection.**
- 3) Work-hour counter: indicates the hours of operation
- 4) Operation lamp
- 5) "Start - Stop" Selector for HP 3-4-5,5 / kW 2,2-3-4 ("Start - NO Load" for HP7,5-10 / kW5,5-7,5)
- 6) Dryer's "OFF - ON" switch
- 7) Dew point indicator



IMPORTANT: WHEN THE SWITCHES (Ref. 2 and Ref. 6) ARE IN POSITION "OFF" THE TERMINALS ARE STILL LIVE.

HP 3-4-5,5 / kW 2,2-3-4

STARTING: - Move the selector Ref. 2 to position "ON".
 - Move the selector Ref. 5 to position "I"; the selector will return automatically.
 - The compressor starts running, operation lamp Ref. 4 lights up.

STOPPING: - Move the selector Ref. 5 to position "0"
 - Lamp Ref. 4 goes out.
 - Move the selector Ref. 2 to position "OFF".

HP 7,5-10 / kW 5,5-7,5 and HP 5,5 / kW 4 for 1ph 60Hz

STARTING: - Move the selector Ref. 2 to position "ON".
 - Move the selector Ref. 5 to position "I"; the selector will return automatically.
 - The compressor starts running, operation lamp Ref. 4 lights up.

STOPPING: - Move the selector Ref. 5 to position "0"
 - Wait at least 30 seconds.
 - Move the selector Ref. 2 to position "OFF".



CAUTION: WAIT AT LEAST 30 SECONDS BEFORE STARTING THE MACHINE AFTER SWITCH OFF.

14.4 COMMAND AND CONTROL PANEL (BASE CONTROLLER VERSION) (FIG.17b)



BEFORE CARRYING OUT THE OPERATION TEST, READ CAREFULLY AND GET A GOOD KNOWLEDGE OF THE CONTROL FUNCTIONS.

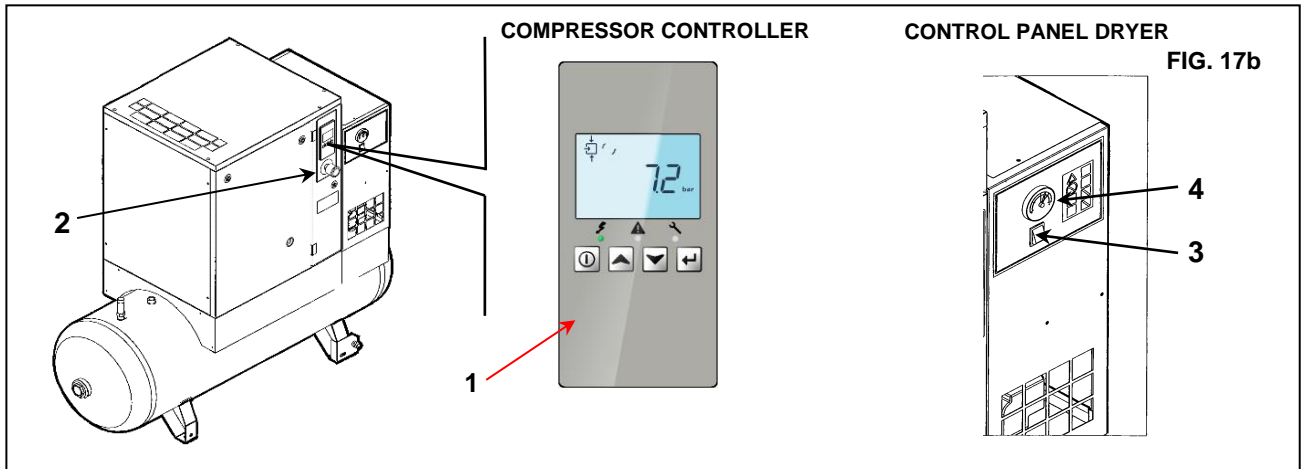

- 1) Electronic controller – Base Controller
- 2) Emergency stop button with rotate-to-unlatch mechanism
- 3) Dryer's "OFF - ON" switch
- 4) Dew point indicator

COMPRESSOR CONTROLLER

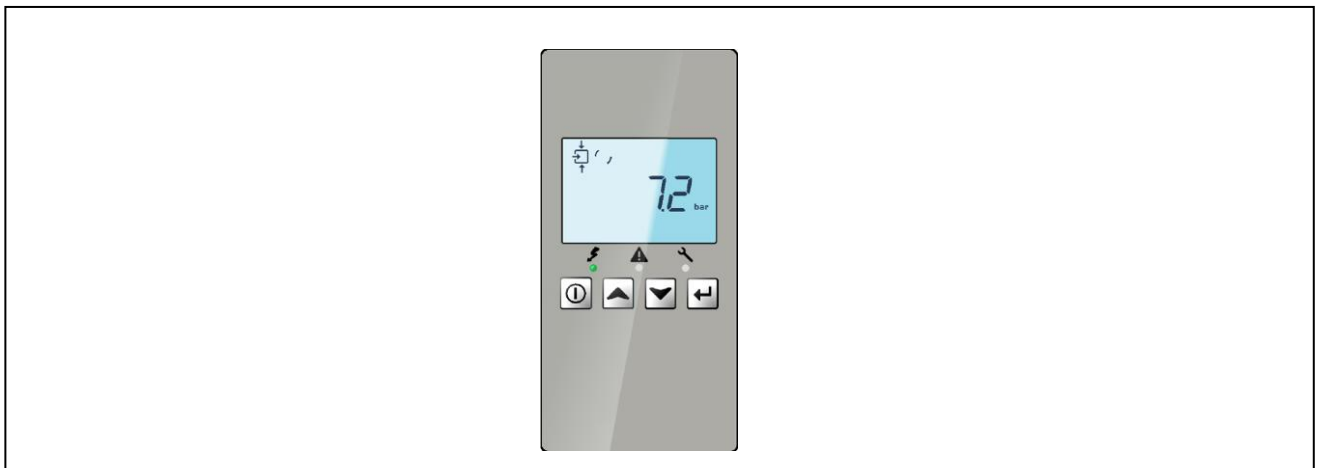

14.4.1 INTRODUCTION

In general, the controller has following functions:

- Controlling the compressor;
- Protecting the compressor;
- Monitoring service intervals;
- Automatic restart after voltage failure (made inactive).

AUTOMATIC CONTROL OF THE COMPRESSOR

For 2.2-4 kW (3-5.5 HP) machines, the controller automatically switches on/off the machines to maintain the pressure in the desired range. For 5.5-7.5 kW (7.5-10 HP) and 4 kW (5,5 HP) single phase 60Hz machines, the controller maintains the net pressure between programmable limits by automatically loading and unloading the compressor. A number of programmable settings, e.g. the unloading and loading pressures, the minimum stop time and the maximum number of motor starts are taken into account. The controller stops the compressor whenever possible to reduce the power consumption and restarts it automatically when the net pressure decreases. If the expected unloading period is short, the compressor is kept running to prevent too short standstill periods.

PROTECTING THE COMPRESSOR

SHUTDOWN WARNING

The shutdown warning is a programmable warning that advises the operator about a possible problem before the shutdown. If one of the measurements exceeds the programmed shutdown warning level, this will also be indicated to warn the operator before the shutdown level is reached.

SHUTDOWN

If the compressor element outlet temperature exceeds the programmed shutdown level or the overload relay of the main motor trips, the compressor will be stopped. This will be indicated on the display of the controller.

SERVICE WARNING

If the service timer exceeds the preset value, the controller advises the operator via the display, to carry out the service maintenance.

AUTOMATIC RESTART AFTER VOLTAGE FAILURE

The controller has a built-in function to automatically restart the compressor when the voltage is restored after voltage failure. This function is deactivated on compressors leaving the factory.

REMOTE CONTROL

This function allows the compressor to start/stop with an external switch signal. Only your dealer can do the activation. Please contact him for further details.

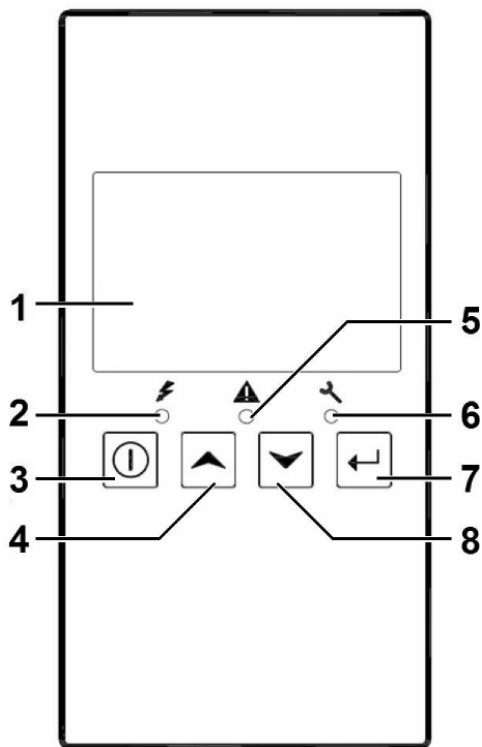

Controller

14.4.2 DETAILED DESCRIPTION

Reference	Designation	Function
1	Display	Shows icons and operating conditions.
2	LED, Voltage on	Indicates that the voltage is switched on.
3	Start/stop button	Keep pressed for 3 seconds to start compressor. Press to stop compressor if running. Use this button to go to previous screen or to end the current action.
4	Scroll button	Use these buttons to scroll through the menu.
5	LED, Warning	Is lit if a warning condition exists.
6	LED, Service	Is lit when service is needed.
7	Enter button	Press 3 seconds to enter in menu. Use this button to confirm the last action. Press 5 seconds to reset alarm.
8	Scroll button	Use these buttons to scroll through the menu.

14.4.3 ICONS USED ON THE DISPLAY

FUNCTION	ICON	DESCRIPTION
Stopped/Running		When the compressor is stopped, the icon stands still. When the compressor is running, the icon is rotating.
Compressor status		Motor stopped
		Running unloaded Running unloaded (blinking for manual stop) (only for 5.5-7.5kW units)
		Running loaded
Machine control mode		Remote start/stop active: Fix: remote switch in ON position Blinking: remote switch in OFF position
Automatic restart after voltage failure		Automatic restart after voltage failure is active
Active protection functions		Emergency stop
Service		Service required
Units	MPa	Pressure unit (Mega Pascal)
	bar	Pressure unit (pounds per square inch)
	PSI	Pressure unit (bar)
	°C	Temperature unit (degree Centigrade)
	°F	Temperature unit (degree Fahrenheit)
		Motor
		A time/delay parameter is displayed. NOTE: <ul style="list-style-type: none"> • x1000: ON if the displayed value is in thousands of • hrs: ON if the displayed value is in hours • s: ON if the displayed value is in sec
		Element outlet temperature

14.4.4 MAIN SCREEN

At power on, the first screen is a test screen (Icon, digit and led are on). The next screen is the Main screen, shown automatically. The Main screen shows:

- The compressor status by means of pictographs;
- The air outlet pressure;



84702D

Main screen with pressure (stopped compressor)

From the Main screen, it is possible with up and down buttons (4-8) to change the view from pressure to temperature of the element outlet.



84703D

Main screen with temperature (stopped compressor)

14.4.5 MAIN FUNCTION

To switch on the compressor, press start/stop button (3) for 3 seconds. The compressor starts, and the status is shown:

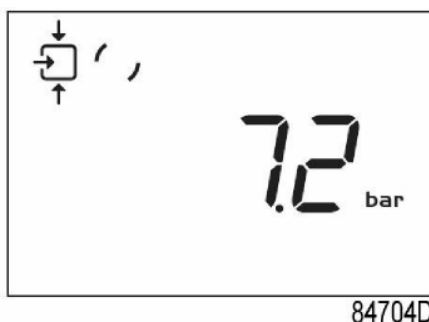

84704D

Screen with running compressor

To stop the compressor, push start/stop button (3). The compressor immediately unloads (for 5.5-7.5 kW / 7.5-10 HP units and 4 kW / 5,5 HP single phase unit) or stops (3-4 kW / 4-5.5 HP units):

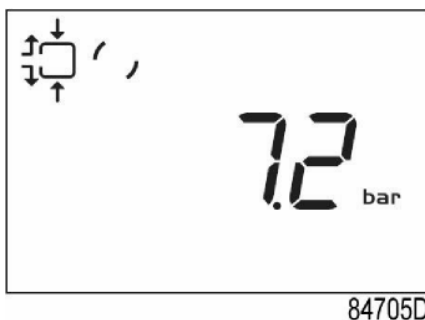

84705D

Screen with unloading compressor

ENGLISH

When the unload time is elapsed (only for 5.5-7.5 kW / 7.5-10 HP units and 4 kW / 5,5 HP single phase unit), the compressor is stopped, and the controller goes back to main screen:



84706D

Main screen with pressure (stopped compressor)

To enter the main menu (starting from the Main screen), press the enter button (7) for 3 seconds. The main menu is shown:



84707D

First screen of main menu

It is possible to scroll in the menu with the up or down buttons (4-8). To select one item, push the enter button (7). To end the current action push start/stop (3) button.

If the emergency stop button is pushed, the compressor stops immediately, and the following screen will appear:



84708D

Emergency stop

When the emergency push button is restored, reset the alarm by pressing the enter button (7) for 5 seconds. The following screen will appear:

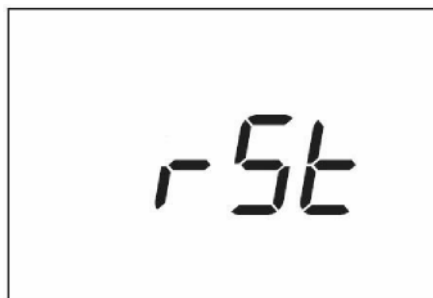

84709D

Alarm reset

14.4.6 SHUTDOWN WARNING

DESCRIPTION

A shutdown warning will appear in the event of:

- A too high temperature at the outlet of the compressor element. **Compressor element outlet temperature**
- If the outlet temperature of the compressor element exceeds the shutdown warning level (factory set at 110°C/ 230°F), warning LED (5) is on.
- Press Scroll up or down buttons (4-8). The screen shows the temperature at the compressor element outlet.

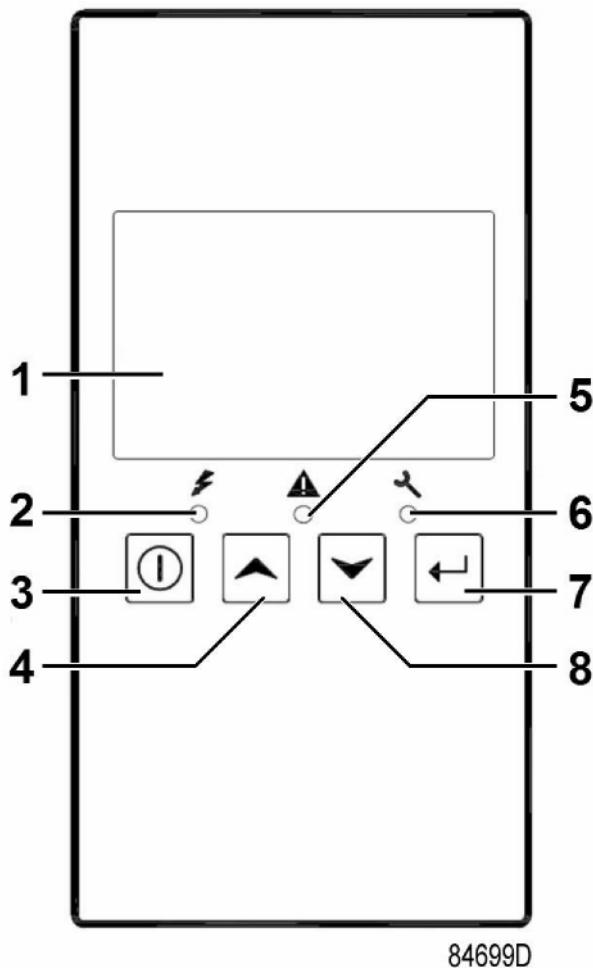

It remains possible to check the actual status of other parameters by pressing the enter button (7) for 3 seconds. Press button (3) to stop the compressor and wait until the compressor has stopped. The warning message will disappear as soon as the warning condition disappears.

14.4.7 SHUTDOWN

DESCRIPTION

THE COMPRESSOR WILL SHUTDOWN:

- In case the temperature at the outlet of the compressor element exceeds the shutdown level (detected by temperature sensor TT11) or by temperature switch (TSHH11/TSHH21).
- In case the pressure at the outlet of compressor exceeds the shutdown level (PT20)
- In case of error of the outlet pressure sensor (PT20) or temperature sensor (TT11).
- In case of overload of the compressor motor (M1)

COMPRESSOR ELEMENT OUTLET TEMPERATURE

If the outlet temperature of the compressor element exceeds the shutdown level (factory setting 115°C/ 239°F):

- The compressor will shutdown.
- Alarm LED (5) will flash.
- The following screen will appear:



84711D

Main screen with shutdown indication, element outlet temperature

- The related pictograph  will appear flashing.
- Scroll Up or Down buttons (4-8) until the current element outlet temperature appears.

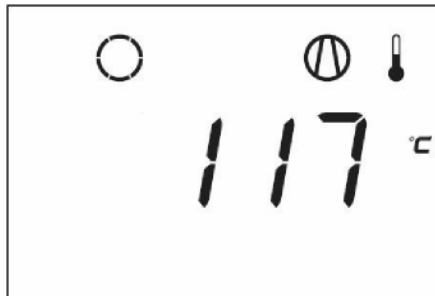

84712D

Shutdown screen, element outlet temperature

The screen shows that the temperature at the outlet of the compressor element is 117 °C.

- When the shutdown condition has been solved, press the Enter button (7) for 5 seconds.
- When <rSt> appears on the display, the compressor can be restarted.

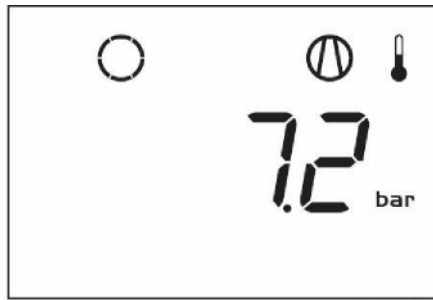
COMPRESSOR OUTLET PRESSURE

84711D

If the outlet pressure of the compressor element exceeds the shutdown level:

- The compressor will shutdown.
- Pressure readout will flash

MOTOR OVERLOAD

In the event of motor overload:

- The compressor will shut down or the compressor can't start
- Alarm LED (5) will flash.
- The following screen will appear:

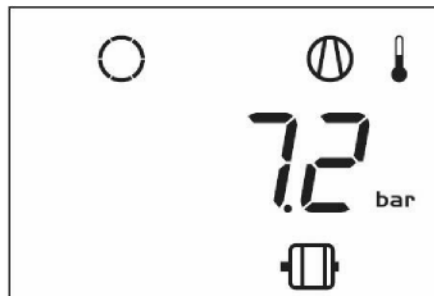

84713D

Main screen with shutdown indication, motor overload

- Contact you dealer for fault troubleshooting.
- When the shutdown condition has been solved, press the enter button (7) for 5 seconds.
- When <rSt> appears on the display, the compressor can be restarted.

ERROR PRESSURE/TEMPERATURE SENSOR

In the event of an error of the outlet pressure sensor (PT20) or temperature sensor (TT11):

- The compressor will shutdown.
- The following screen will appear:

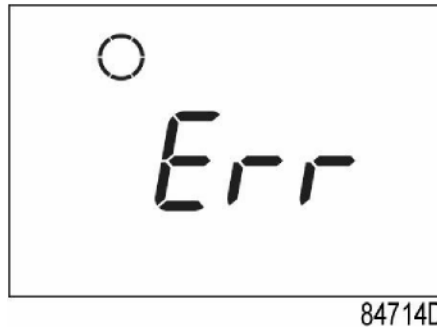

Example of sensor error

- When the shutdown condition has been solved, press the Enter button (7) for 5 seconds.
- When <rSt> appears on the display, the compressor can be restarted.

14.4.8 SERVICE WARNING**DESCRIPTION**

A service warning will appear when the service timer has reached the preset time interval.

If the service timer exceeds the programmed time interval, alarm LED (6) is blinking with a following screen:

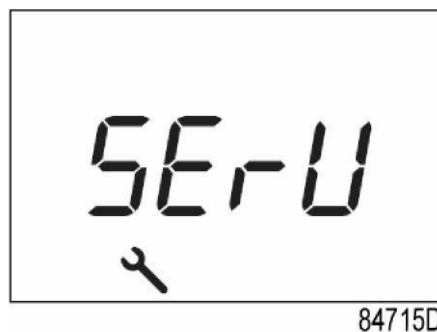

Blinking screen

- Press Enter button (7) to enter the main menu.
- Select <dAtA> and press Enter button (7) to enter the data menu.
- Scroll (buttons 4-8) until <d.6> appear, the service symbol is shown.
- Press enter button (7).
- The actual reading of the service timer is shown in <hrs>.



Example of running hours screen

The example screen shows that the service timer is at 2002 hours.

Stop the compressor, switch off the voltage and carry out the required service actions. After servicing, reset the service timer.

See section **Calling up/resetting the service timer**.

14.4.9 SCROLLING THROUGH ALL SCREENS

COMPRESSOR CONTROLLER MENU TREE

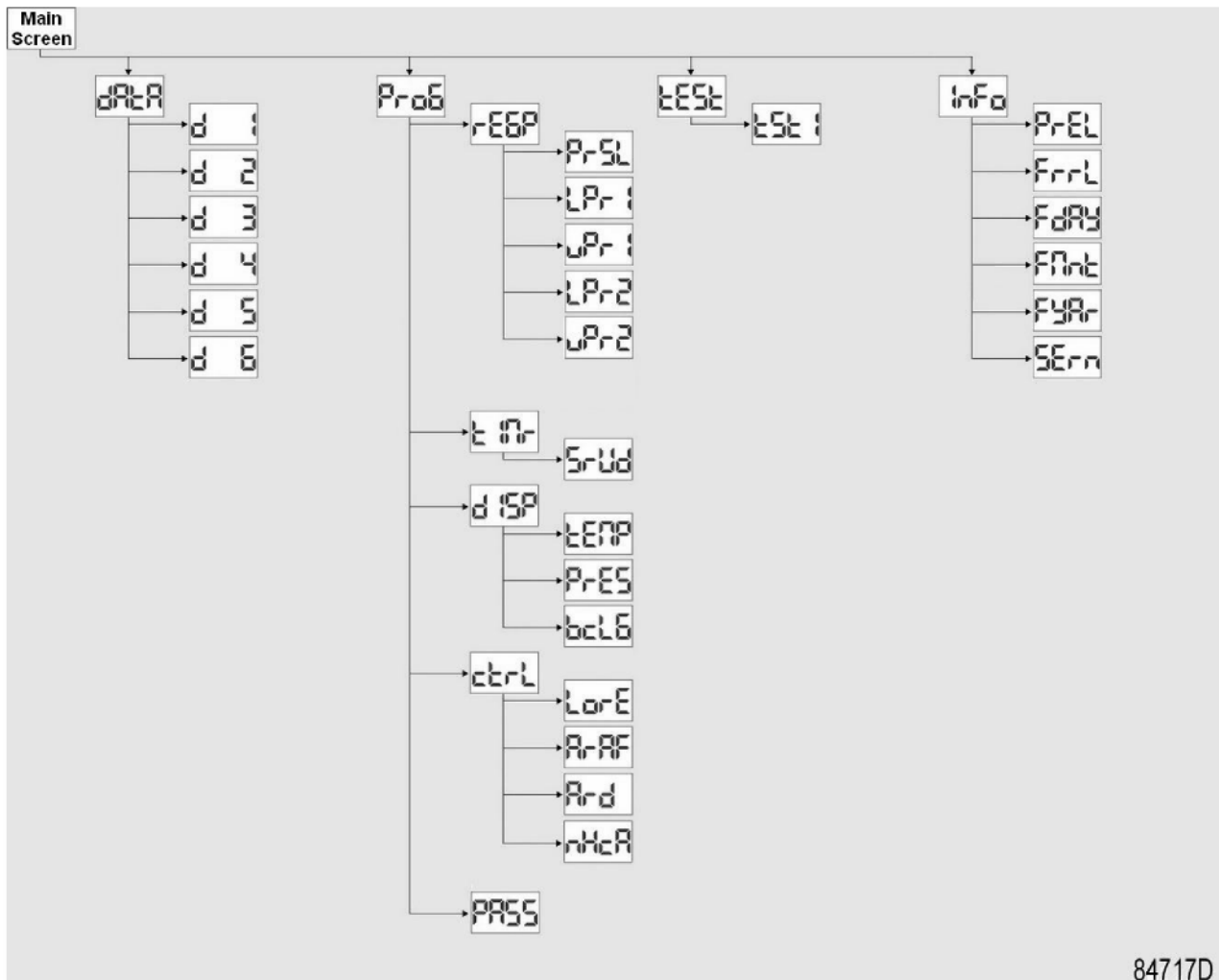

General overview of the menu

From the Main screen press the enter button (7) for 3 seconds to enter the Menu. You will find the following items:

- **Data menu:** Data counters parameters.
- **Programming menu:** Submenu of Regulation pressure, Timer, Display setting and Control setting.
- **Test menu:** Display test.
- **Info menu:** Information of firmware release.

OVERVIEW OF THE SCREENS

Menu item	Submenu	Digital input screen	Designation
<dAtA> Data		<d.1>	Calling up running hours
		<d.2>	Calling up motor starts
		<d.3>	Calling up module hours
		<d.4>	Calling up loading hours
		<d.5>	Calling up load solenoid valve (only for 5.5-7.5kW units)
		<d.6>	Calling up service timer
<ProG> Programming	<rEG.P> Regulation Pressure	<Pr.SL>	Calling up modifying pressure band selection
		<LPr.1>	Calling up modifying pressure band settings
		<uPr.1>	Calling up modifying pressure band settings
		<LPr.2>	Calling up modifying pressure band settings
		<uPr.2>	Calling up modifying pressure band settings
		<tiMr> Timer	<SrV.d>
	<diSP> Display	<tEMP>	Calling up modifying unit of temperature
		<PrES>	Calling up modifying unit of pressure
		<bC.LG>	Calling up modifying time of backlight
	<Ctrl> Control	<Lo.rE>	Local/remote start/stop
		<Ar.Af>	Calling up automatic restart after voltage failure
		<Ar.d>	Delay automatic restart after voltage failure
		<nHCA>	Number of hourly compressor activation (only for 5.5-7.5 kW / 7.5-10 HP units and 4 kW / 5,5 HP single phase unit)
	<PASS>		Activating password protection
	<tEst> Test		<tSt. 1>
<info> Info		<P.rEL>	Parameter Map Release
		<F.rRI>	Firmware Release
		<F.dAY>	Firmware Release Day
		<F.Mnt>	Firmware Release Month
		<F.YAr>	Firmware Release Year
		<SEr.n>	Serial number

14.4.10 CALLING UP RUNNING HOURS

Starting from the Main screen:

- Press Enter button (7) for 3 seconds to enter the Main menu.
- Select <dAtA> and press Enter button (7) to enter the Data menu.
- Scroll Up or Down buttons (4-8) until <d.1> and the motor stopped symbol is shown.
- Press Enter button (7): the running hours are shown.

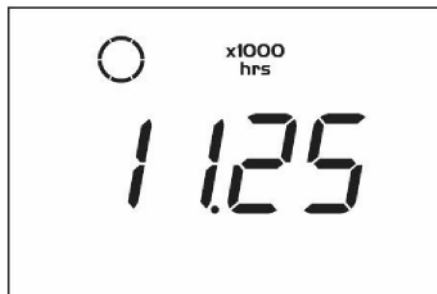

84718D

The screen shows the unit used <x1 000 hrs> and the value <1.25>: the running hours of the compressor are 11250 hours.

14.4.11 CALLING UP LOAD SOLENOID VALVE (ONLY FOR 5.5-7.5KW UNITS)

Starting from the Main screen:

- Press Enter button (7) for 3 seconds to enter the Main menu.
- Select <dAtA> and press Enter button (7) to enter the Data menu.
- Scroll Up or Down buttons (4-8) until <d.2> and the motor symbol is shown.
- Press Enter button (7): the number of motor starts is shown.

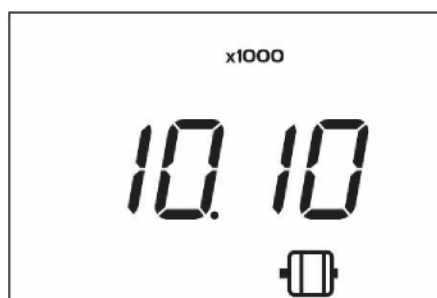

84719D

This screen shows the number of motor starts (x1 or - if <x1000> lights up - x1 000). In the above example, the number of motor starts is 10100.

14.4.12 CALLING UP MODULE HOURS

Starting from the Main screen:

- Press Enter button (7) for 3 seconds to enter the Main menu.
- Select <dAtA> and press Enter button (7) to enter the Data menu.
- Scroll Up or Down buttons (4-8) until <d.3> and <hrs> is shown.
- Press Enter button (7): the module time appears.



84720D

In the example shown, the screen shows the unit used <hrs> and the value <5000>: the controller module has been in service for 5000 hours.

14.4.13 CALLING UP LOADING HOURS

Starting from the Main screen:

- Press Enter button (7) for 3 seconds to enter the Main menu.
- Select <dAtA> and press Enter button (7) to enter the Data menu.
- Scroll Up or Down buttons (4-8) until <d.4> and the running loaded symbol is shown.
- Press Enter button (7): the loading time is shown.



84721D

The screen shows the unit used <hrs> (or <x1000 hrs>) and the value <1755>: the compressor has been running loaded for 1755 hours.

14.4.14 CALLING UP LOAD SOLENOID VALVE (ONLY FOR 5.5-7.5KW UNITS)

Starting from the Main screen:

- Press Enter button (7) for 3 seconds to enter the Main menu.
- Select <dAtA> and press Enter button (7) to enter the Data menu.
- Scroll Up or Down buttons (4-8) until <d.5> and the running loaded symbol is shown.
- Press Enter button (7): the number of loadings is shown.

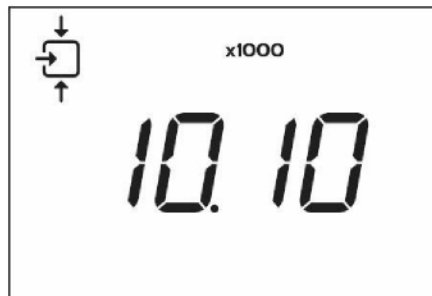

84722D

This screen shows the number of loading actions (x1 or - if <x1 000> lights up - x1 000). In the above example, the number of unload to load actions is 10100.

14.4.15 CALLING UP/RESETTING THE SERVICE TIMER

Starting from the Main screen:

- Press Enter button (7) for 3 seconds to enter the Main menu.
- Select <dAtA> and press Enter button (7) to enter the Data menu.
- Scroll Up or Down buttons (4-8) until <d.6> and <hrs> is shown.

Press Enter button (7): the loading time is shown.



84723D

This screen shows the unit used <hrs> (or <x1 000 hrs>) and the value <1191>. In the example shown, the compressor has run 1191 hours since the previous service.

To reset the timer, contact your supplier.

14.4.16 CALLING UP/MODIFYING PRESSURE BAND SELECTION

Starting from the Main screen:

- Press Enter button (7) for 3 seconds to enter the Main menu.
- Select <ProG> and press Enter button (7) to enter the Programming menu.
- Scroll Up or Down buttons (4-8) to <reG.P> for regulation pressure.
- Press Enter button (7) to enter the submenu.

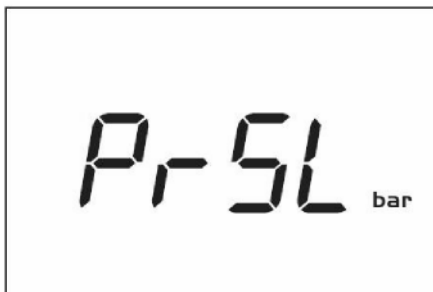

84724D

- Scroll Up or Down buttons (4-8) until <PrSL> is shown and then press Enter button (7).
- Pressure band 1 (<SEL. 1>) is shown. Scroll Up or Down buttons (4-8) to pressure band 2 (<SEL.2>).
- Press Enter button (7) on the desired pressure band.

14.4.17 CALLING UP/MODIFYING PRESSURE BAND SETTINGS

Starting from the Main screen:

- Press Enter button (7) for 3 seconds to enter the Main menu.
- Select <ProG> and press Enter button (7) to enter the Programming menu.
- Scroll Up or Down buttons (4-8) to <reG.P> for regulation pressure.
- Press Enter button (7) to enter the submenu.

<LPr. 1> is parameter of Load Pressure band 1 <uPr. 1> is parameter of Unload Pressure band 1 <LPr.2> is parameter of Load Pressure band 2 <uPr.2> is parameter of Unload Pressure band 2

- Scroll Up or Down buttons (4-8) and press Enter button (7) to select parameter.
- The actually used pressure is shown. Scroll Up or Down buttons (4-8) to set pressure value and press Enter button (7) to confirm. The unit blinks and the new setting is saved.

14.4.18 CALLING UP/MODIFYING THE UNIT OF TEMPERATURE

The unit of temperature measurement can only be changed when the compressor is stopped. Starting from the Main screen:

- Press Enter button (7) for 3 seconds to enter the Main menu.
- Select <ProG> and press Enter button (7) to enter the Programming menu.
- Scroll Up or Down buttons (4-8) to <diSp> for display settings.
- Press Enter button (7) to enter the submenu.
- Scroll Up or Down buttons (4-8) to <tEMP> and press Enter button (7).
- The actually used unit is shown. Possible settings are <°C > and <°F >.
- Scroll Up or Down buttons (4-8) to set the unit of temperature and press Enter button (7) to confirm. The unit blinks and is saved.

14.4.19 CALLING UP/MODIFYING THE UNIT OF PRESSURE

The unit of pressure measurement can only be changed when the compressor is stopped. Starting from the Main screen:

- Press Enter button (7) for 3 seconds to enter the Main menu.
- Select <ProG> and press Enter button (7) to enter the Programming menu.
- Scroll Up or Down buttons (4-8) to <diSp> for display settings.
- Press Enter button (7) to enter the submenu.
- Scroll Up or Down buttons (4-8) to <PrES> and press Enter button (7).
- The actually used unit is shown. Possible settings are <bar>, <psi> and <MPa>.
- Scroll Up or Down buttons (4-8) to set the unit of pressure and press Enter button (7) to confirm. The unit blinks and is saved.

14.4.20 CALLING UP/MODIFYING BACKLIGHT TIME

The backlight will be activated after pressing any button and for the interval of time set in the parameter <bC.LG> (in sec).

Starting from the Main screen:

- Press Enter button (7) for 3 seconds to enter the Main menu.
- Select <ProG> and press Enter button (7) to enter the Programming menu.
- Scroll Up or Down buttons (4-8) to <diSp> for display settings.
- Press Enter button (7) to enter the submenu.
- Scroll Up or Down buttons (4-8) to <bC.LG> and press Enter button (7).
- The current backlight setting is shown. It is possible to set a value between 0s and 1 20s.
- Scroll Up or Down buttons (4-8) to set the time of backlight and press Enter button (7) to confirm. The unit blinks and is saved.

14.4.21 ACTIVATING AUTOMATIC RESTART AFTER VOLTAGE FAILURE

DESCRIPTION

This function allows the compressor to restart automatically after voltage failure. Your dealer can only do the activation. Please contact him for further details.

After any power failure, before restarting, the compressor will wait for a fixed time. When delay time is running, the display will show the related countdown value as below:



Example countdown delay time of automatic restart after power failure.

14.4.22 KEYBOARD LOCK

Keep both Up and Down buttons pressed for more than 3 seconds to lock or unlock the keyboard.

- The display will show the label <Loc> blinking for 3 seconds if the keyboard has been locked.
- The display will show the label <UnLo> blinking for 3 seconds if the keyboard has been unlocked.

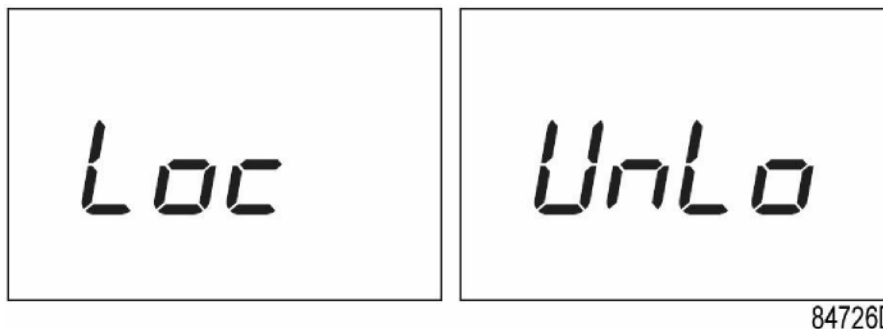

Example Lock/unlock screen.

15.0 ORDINARY MAINTENANCE TO BE DONE BY THE USER



BEFORE CARRYING OUT ANY MAINTENANCE IT IS OBLIGATORY TO STOP THE MACHINE AND DISCONNECT IT FROM THE POWER MAINS AND FROM THE COMPRESSED AIR DISTRIBUTION NETWORK.

The maintenance jobs described in this chapter may be carried out by the user. The more complex maintenance jobs which require professionally skilled personnel are listed in the chapter on **GENERAL ROUTINE MAINTENANCE**. (See Chap. 21.0)

15.1 MAINTENANCE PROGRAMME

- OPERATIONS THAT MAY BE CARRIED OUT BY THE USER
- ■ OPERATIONS THAT REQUIRE SKILLED PERSONNEL; THESE OPERATIONS ARE ILLUSTRATED IN PART "B" OF THIS MANUAL.

The indicated oil exchange intervals are valid for standard operating conditions and nominal operating. Exposure of the compressor to external pollutants or operation at high humidity combined with low duty cycles may require a shorter oil exchange interval. Contact your supplier if in doubt.

Every Day (after use)	<ul style="list-style-type: none"> ■ Drain the condensate from the air tank ■ Check the automatic drainage of the condensate (dryer)
Every 50 working hours (or at least weekly)	<ul style="list-style-type: none"> ■ Drain condensate from the oil tank ■ Check the oil level ■ Clean the filtering panel
Every 500 hours (or at least every 3 months)	<ul style="list-style-type: none"> ■ Clean the air suction filter ■ Clean the condenser battery (on the dryer if fitted) ■ Clean the filter of the automatic condensate drain ■ ■ Check belt tension
Every 2000 hours (or at least every 1 year)	<ul style="list-style-type: none"> ■ Change the suction filter ■ ■ Change the oil ■ ■ Change the oil filter ■ ■ Check belt tension and adjust or change if necessary ■ ■ Replace the filter of automatic condensate drain (2902016102) ■ ■ Clean the finned surface of the air-oil cooler ■ ■ Safety temperature test ■ ■ Retighten all power cable connections
Every 4000 hours (or at least every 2 years)	<ul style="list-style-type: none"> ■ ■ Change the filtering panel (black foam) ■ ■ Change the oil separating filter ■ ■ Replace drain kit (2200902017) ■ ■ Replace the belts
Every 6000 hours (or at least every 3 years)	<ul style="list-style-type: none"> ■ ■ Service kit for the inlet valve. ■ ■ Replace the electronic drain. ■ ■ Service kit minimum pressure valve and thermostatic valve

15.2 DRAINING CONDENSATE FROM THE OIL TANK (FIG.18)

If the compressor work cycle contemplates long pauses during which the machine cools down, a certain amount of condensate will gather in the oil tank. This happens, for example, when stopping overnight or at weekends. The condensate must be drained off every 50 hours **or every week**. This operation may be performed only when the machine is cold, that is when it has been switched off for at least 8 hours.



BEFORE DRAINING THE CONDENSATE, IT IS OBLIGATORY TO STOP THE MACHINE AND DISCONNECT IT FROM THE POWER MAINS.

Proceed as follows:

- Switch off the machine with pushbutton Ref. 1 Fig. 18.
- Press the button switch Ref. 2 Fig. 18 (on the dryer if fitted).
- Disconnect the power supply by means of the disconnecter switch, Ref. 3 (on the screw-compressor) and Ref. 4 (on the dryer if fitted) Fig. 18.

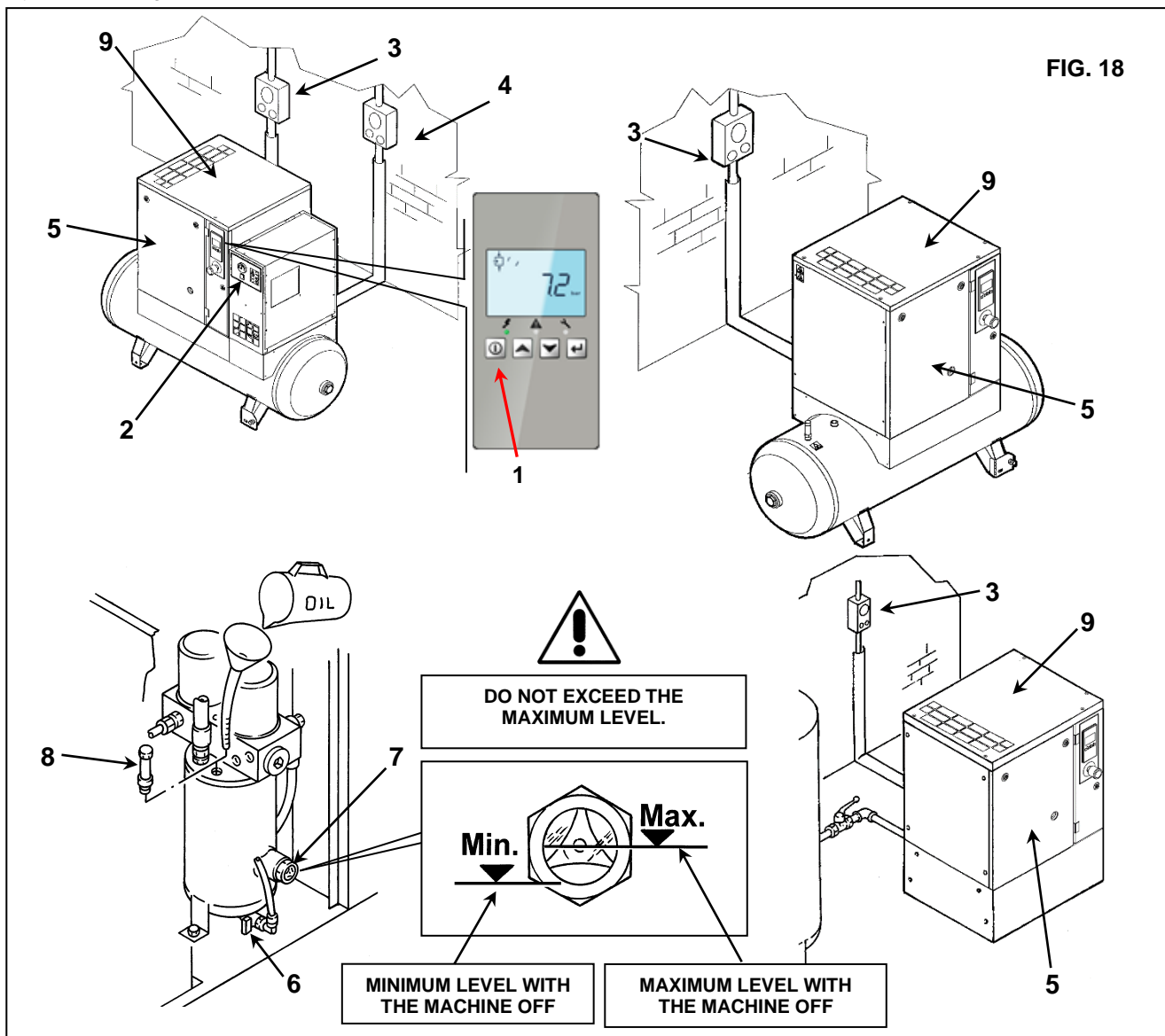

- Wait for the machine to cool down.
- Remove the panel Ref. 5 Fig. 18 with the key provided.
- **SLOWLY** turn on the tap Ref. 6 Fig. 18 and let the condensate flow out.
- When the first traces of oil appear, turn off the tap.



CONDENSATE MUST BE DISPOSED OF IN CONFORMITY WITH THE LOCAL REGULATIONS IN FORCE.

- Check the oil level on the indicator Ref. 7 Fig. 18.
- If the oil level is under the minimum, top up as described at point 15.3.



USE OIL OF THE SAME TYPE AS THAT ALREADY IN THE MACHINE; DO NOT MIX DIFFERENT TYPES OF OIL

15.3 CHECK OIL LEVEL AND TOP UP

- Switch off the machine with pushbutton Ref. 1 Fig. 18.
- Press the button switch Ref. 2 Fig. 18 (on the dryer if fitted).
- Disconnect the power supply by means of the disconnect switch, Ref. 3 (on the screw-compressor) and Ref. 4 (on the dryer if fitted) Fig. 18.
- **WAIT A FEW MINUTES FOR THE FOAM IN THE OIL COLLECTOR TO ABATE.**
- Check the oil level on the indicator Ref. 7 Fig. 18.
- If the oil level is below minimum, fill up as follows



USE OIL OF THE SAME TYPE AS THAT ALREADY IN THE MACHINE; DO NOT MIX DIFFERENT TYPES OF OIL.

BEFORE CARRYING OUT ANY OPERATION ON THE MACHINE, ENSURE THAT THE ELECTRIC POWER SUPPLY HAS BEEN DISCONNECTED.

- Open the front protection Ref. 5 Fig. 18 using the special key.
- Remove the fixed protection device (machine cover) Ref. 9 Fig. 18.
- Slowly unscrew the oil cap Ref. 8 Fig. 18, ensuring there is no pressure inside.
- Top up to maximum level Ref. 7 Fig. 18, with oil of the same type in the compressor.
- Close the oil manifold cap Ref. 8 Fig. 18.
- Close the fixed protection (machine cover) Ref. 9 Fig. 18 device again, using the appropriate safety screws.
- Close the front protection Ref. 5 Fig. 18.

**CHECK OIL LEVEL ONLY AFTER UNIT HAS RUN FOR AT LEAST 5 MINUTES.
DO NOT WAIT TOO LONG AFTER UNIT IS STOPPED, AND FOAM IS DISAPPEARED: OIL MAY MIGRATE**

OIL LEVEL CHECK

Running unit:

- Foam level is in the center of sight glass.

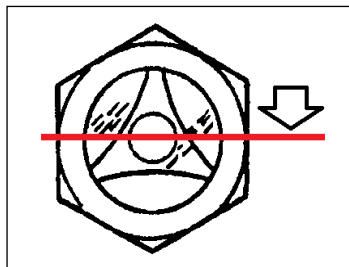

Machine just stopped:

- When foam disappears, the sight glass must be almost completely filled with oil.

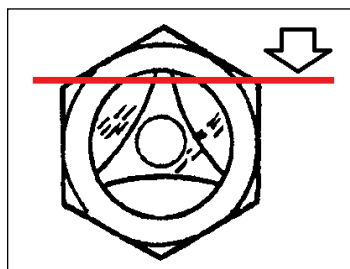

ATTENTION:

- Do not check level if machine is standing for more than 10 minutes.
- Do not overfill.

15.4 CLEANING THE FILTERING PANEL

- Stop the machine.
- Turn on the differential supply switch Rif. 3 Fig. 20.
- Clean the filtering panel Rif. 1 Fig. 19 with a jet of air wash it with water, **do not use solvents**.

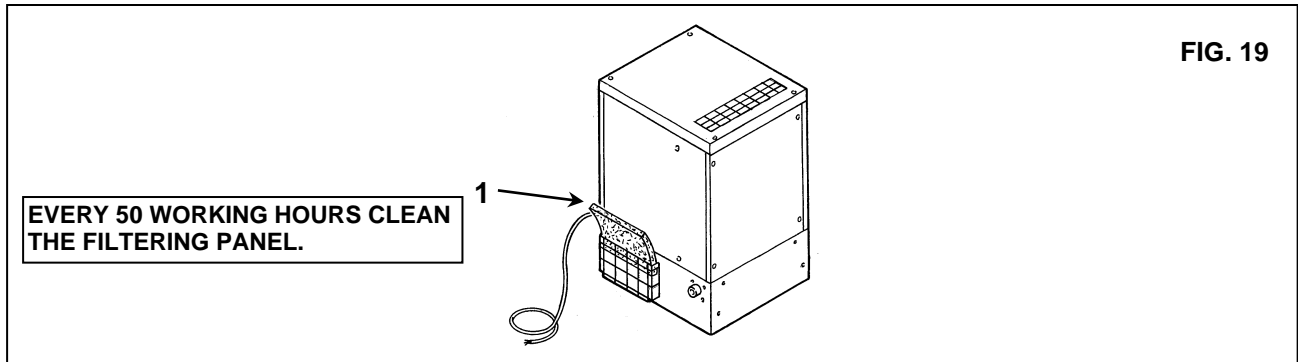

ENGLISH

15.5 CLEANING THE SUCTION FILTER OR CHANGING THE FILTER (FIG.20)

- Stop the machine.
- Press the button switch Ref. 2 Fig. 20 (on the dryer if fitted)
- Turn on the differential supply switch, Ref. 3 (on the screw-compressor) and Ref. 4 (on the dryer if fitted) Fig. 20.



HOT PARTS INSIDE

- Remove the fixed protection device (machine cover) Ref. 5 Fig. 20.
- Remove the cover Ref. 6 Fig. 20 (Check the direction of the arrow).
- Remove the filter Ref. 7 Fig. 20.

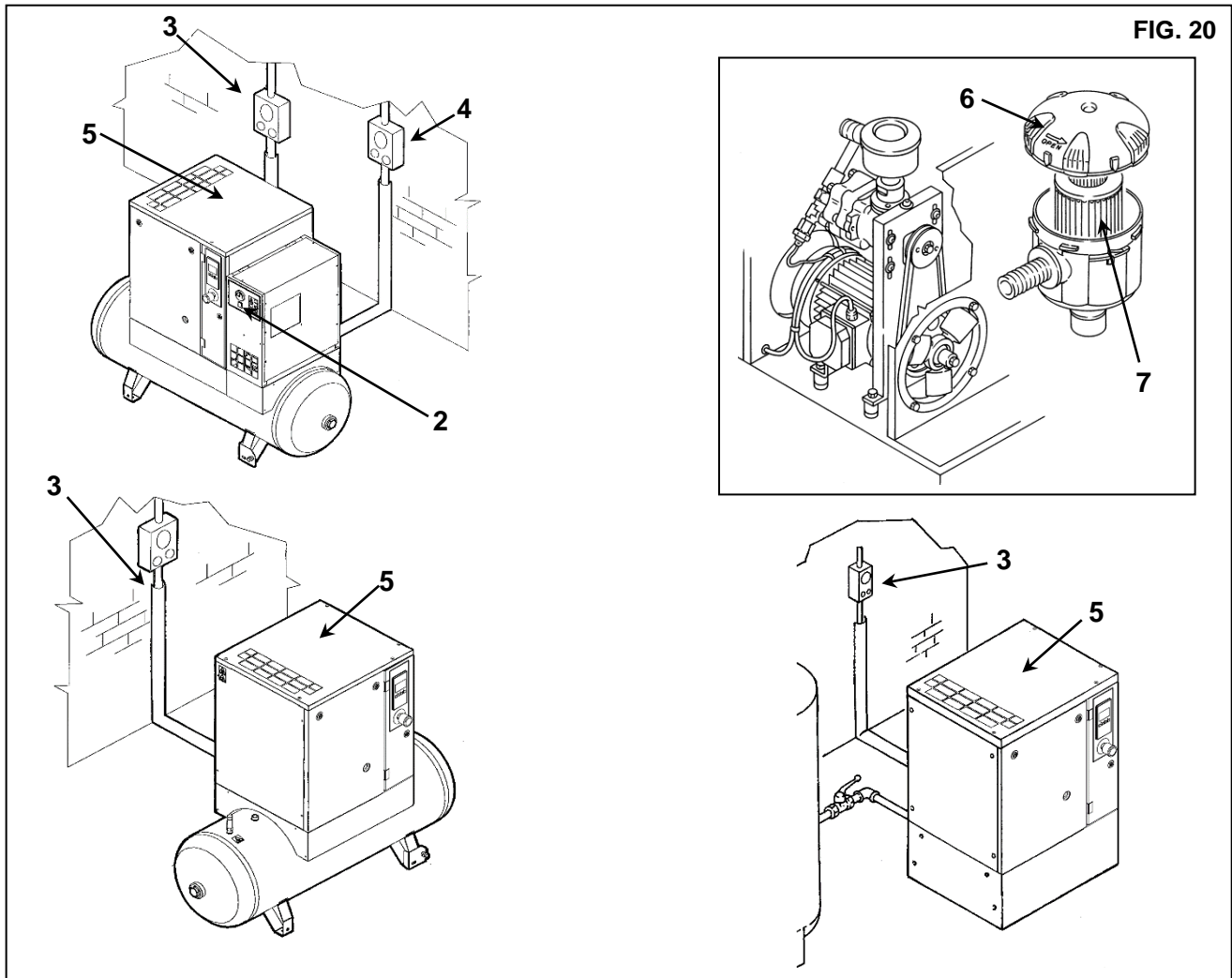

AVOID DROPPING FOREIGN BODIES INTO THE SUCTION MANIFOLD.

- Clean the filter with a jet of air, working from inside to outside, **DO NOT USE WATER OR SOLVENTS**. Alternatively, fit a new filter.
- Clean the disk on which the filter rests with a clean cloth.
- Fit the filter and the cover.
- If necessary, dispose of the old filter in conformity with the local regulations in force.
- Close the fixed protection device (machine cover) Ref. 5 Fig. 20 again, using the appropriate safety screws.

15.6 CHECK THE AUTOMATIC DRAINAGE OF THE CONDENSATE (DRYER) AND MANUAL DRAINAGE (AIR TANK) (FIG.21)



BEFORE CARRYING OUT ANY MAINTENANCE IT IS MANDATORY TO STOP THE MACHINE AND DISCONNECT IT FROM THE POWER MAINS AND FROM THE COMPRESSED AIR DISTRIBUTION NETWORK.

The automatic and manual condensation drain (Ref. 8 and Ref. 11 Fig. 21) must be checked every day.

Proceed as follows:

- Press the "TEST" button, Ref. 8 Fig. 21, for a few seconds to check if the condensation is correctly drained from the pipe
- Check manual condensation draining from the tank, to ensure that condensation is correctly released from the valve, Ref. 11 Fig. 21 (**PURGE EVERY DAY**).

15.7 CLEANING THE CONDENSER FINS (FOR DRYER) (FIG.21)



BEFORE CARRYING OUT ANY MAINTENANCE IT IS OBLIGATORY TO STOP THE MACHINE AND DISCONNECT IT FROM THE POWER SUPPLY AND FROM THE COMPRESSED AIR DISTRIBUTION NETWORK.

The condenser must be cleaned every month (Ref. 6 Fig. 21).

Proceed as follows:

- Stop the compressor.
- Switch off the dryer by pressing the STOP button Ref. 2 Fig. 21
- Open (disconnect) the differential supply switch, Ref. 3 (on the screw-compressor) and Ref. 4 (on the dryer if fitted) Fig. 21.



HOT PARTS INSIDE

- Remove the cover panel Ref. 5 Fig. 21
- Clean the condenser fins Ref. 6 Fig. 21 with compressed air. **DO NOT USE WATER OR SOLVENTS.**
- Close the cover panel Ref. 5 Fig. 21.

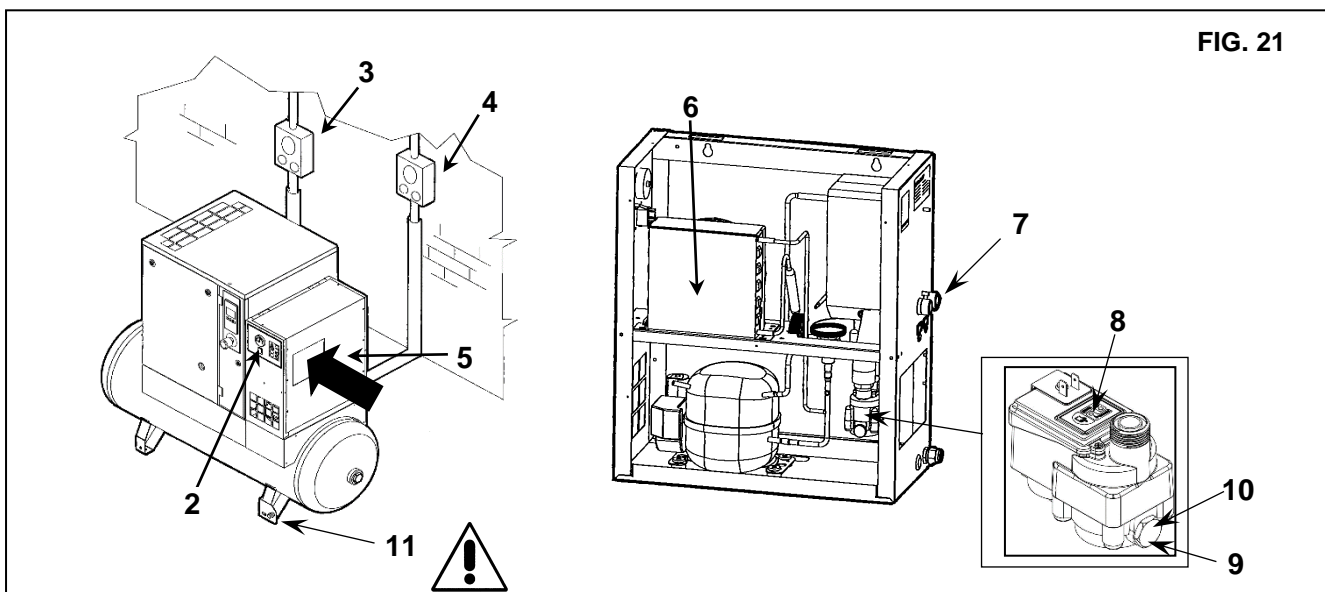

FIG. 21

15.8 CLEAN THE FILTER OF THE AUTOMATIC DRAIN FOR DRYER (Ref. 9 - 10 Fig. 21)



BEFORE CARRYING OUT ANY MAINTENANCE IT IS OBLIGATORY TO STOP THE MACHINE AND DISCONNECT IT FROM THE POWER SUPPLY AND FROM THE COMPRESSED AIR DISTRIBUTION NETWORK.

Proceed as follows:

- Close the air net valve Ref. 7 Fig. 21
- Stop the compressor.
- Switch off the dryer by pressing the STOP button Ref. 2 Fig. 21
- Open (disconnect) the differential supply switch, Ref. 3 (compressor) and Ref. 4 (dryer) Fig. 21.
- Release the pressure from the dryer and tank by opening the drainage valve Ref. 11 Fig. 21.
- Remove the plug Ref. 9 Fig. 21.
- Take out the filter trap Ref. 10 Fig. 21.
- Clean the filter Ref. 10 Fig. 21 with a jet of air, blowing from inside to outside.
- Install the filter and the plug.

16.0 PERIODS OF INACTIVITY (FIG. 22)

If it's required that the machine stays inactive for a long period (above one week):

- Run machine 30 minutes at full load to purge the machine from condensate.
- Stop the machine.
- Close the valve Ref. 1 and Ref. 2 Fig. 22.
- Press the button switch Ref. 5 Fig. 22 (if unit with dryer)
- Open (disconnect) the differential supply switch, Ref. 6 (on the compressor) and Ref. 7 (if unit with dryer) Fig. 22.
- Release the pressure from the dryer and air tank by opening the drain outlet valve Ref. 8 Fig. 22.
- Close the valve Ref. 8 Fig. 22 after the residual pressure in the unit is all released.
- One day after stop, there may be some condensate in the bottom of the oil tank. Drain this condensate.

During periods of inactivity, the unit must be protected against atmospheric agents, dust and humidity which could damage the motor and the electrical system.

For stops above 2 weeks it's recommended to install VCI foam in the cubicle and canopy.

To restart the machine after periods of inactivity above 3 months, consult the manufacturer.

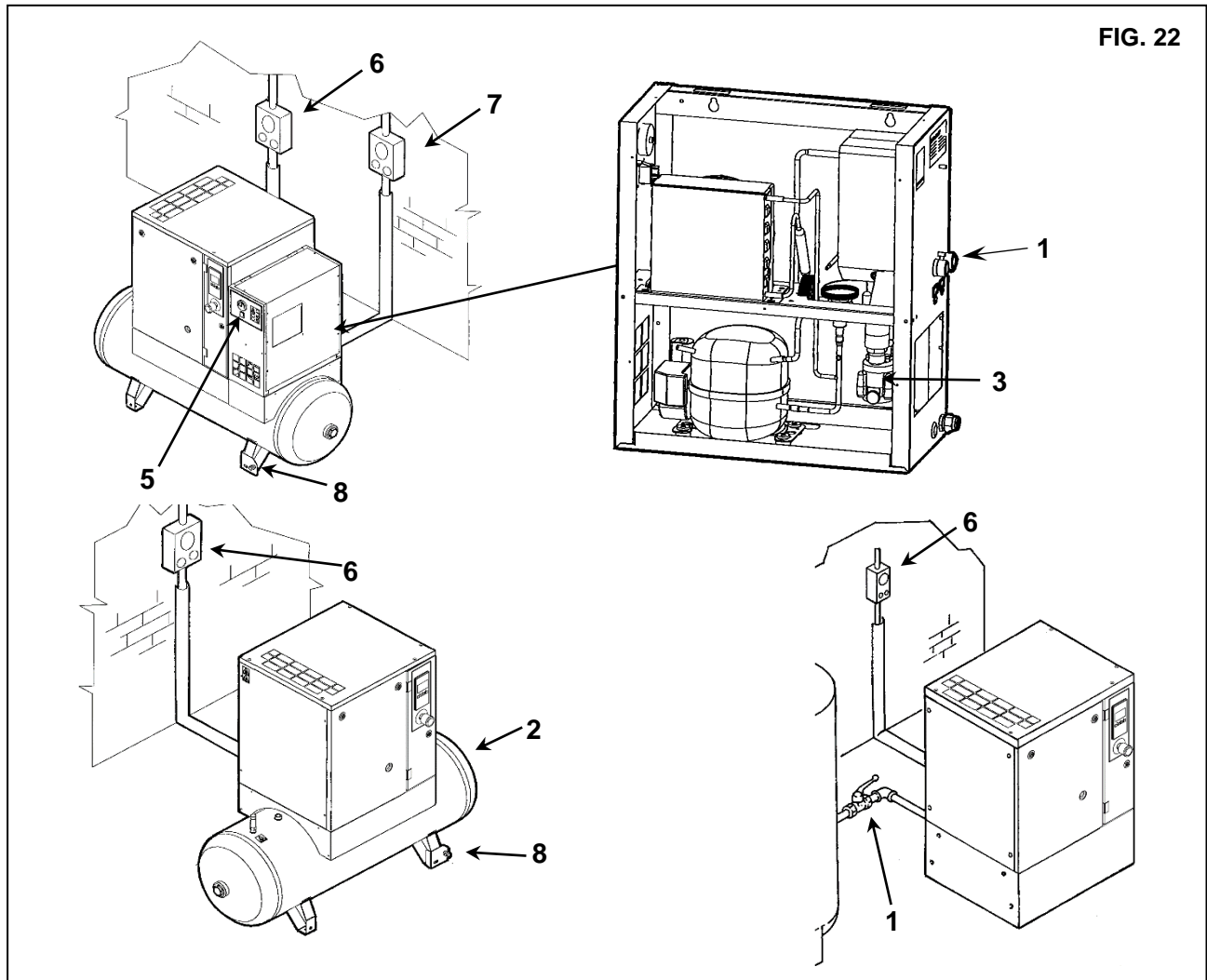

FIG. 22

17.0 SCRAPPING THE UNIT

If the machine is to be scrapped, it must be dismantled into parts of the same material, to be disposed of according to the local regulations in force.



ALWAYS RESPECT THE LOCAL REGULATIONS FOR DISPOSING OF OLD OIL AND OTHER POLLUTING MATERIALS SUCH AS SOUND-ABSORBING, INSULATING FOAM, ETC.

18.0 LIST OF SPARE PARTS FOR REGULAR MAINTENANCE (FIG. 23)

Ref	DESCRIPTION	Code	HP 3 - 4 - 5,5 kW 2,2 - 3 - 4	HP 7,5 - 10 kW 5,5 - 7,5
			8 - 10 bar	8 - 10 bar
1	Suction air filter	6211 4737 50	■	
1	Suction air filter	6211 4739 50		■
2	Oil filter	6211 4726 50	■	
3	Separator cartridge	6221 3726 50	■	
3	Separator cartridge	6221 3728 50		■
4	Filtering panel (version on floor base frame)	2202 2607 00	■	■

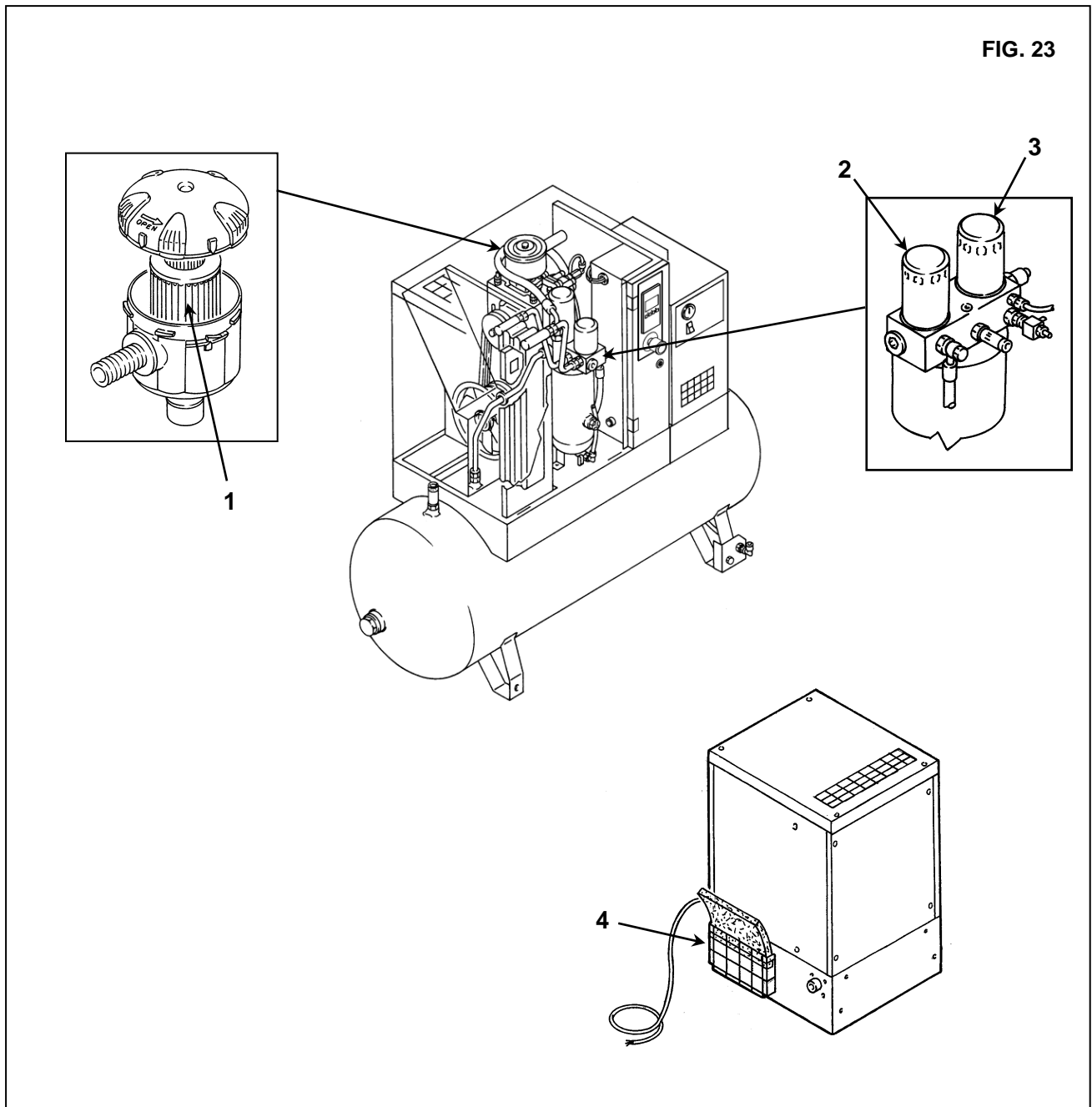



19.0 TROUBLE-SHOOTING AND EMERGENCY REMEDIES

N.B. OPERATIONS MARKED ■ ■ MUST BE CARRIED OUT BY PROFESSIONALLY SKILLED PERSONNEL AUTHORISED BY THE MANUFACTURER



ALL WORK MUST BE CARRIED OUT BY PROFESSIONALLY SKILLED PERSONNEL. BEFORE CARRYING OUT ANY MAINTENANCE JOBS IT IS MANDATORY TO STOP THE MACHINE AND DISCONNECT IT FROM THE POWER SUPPLY.

19.1 TROUBLE-SHOOTING AND EMERGENCY REMEDIES FOR SCREW COMPRESSOR

FAULT FOUND	POSSIBLE CAUSES	OBSERVATIONS
<p>1) The machine does not start</p>	<p>1A - no power</p> <p>1B - the transformer protection fuse is interrupted</p>	<ul style="list-style-type: none"> - check the power supply line, Chapter 12.2 - replace fuse with new one of same size.
<p>2) The machine does not start The red LED (Ref. 5 Fig. 17/A) is flashes. The following pictograph appears intermittently:</p> <div style="text-align: center;">  </div>	<p>2A - Phases incorrect</p> <p>2B - the main motor protection device has tripped</p> <p>2C – Temperature switch on element outlet has tripped</p>	<ul style="list-style-type: none"> - Verify phase sequence - to check possible motor failure - environment temperature too high; improve ventilation in the compressor room, Chapter 9.2 ■ ■ - cooling radiator is dirty, clean the radiator - oil level too low; top up the oil tank
<p>3) The machine does not start The red LED (Ref. 5 Fig. 17/A) is flashes. The following pictograph appears intermittently:</p> <div style="text-align: center;">  </div>	<p>3A - The oil high temperature protection has tripped</p>	<ul style="list-style-type: none"> - environment temperature too high; improve ventilation in the compressor room, Chapter 9.2 ■ ■ - cooling radiator is dirty, clean the radiator - oil level too low; top up the oil tank
<p>4) The compressor does not reach working pressure</p>	<p>4A - the compressed air consumption is too high</p> <p>4B - the discharge electrovalve remains open, Ref. EV/SC wiring diagram</p>	<ul style="list-style-type: none"> ■ ■ - check the electric system
<p>5) Excess oil consumption</p>	<p>5A - deteriorated oil separating filter or oil level is too high</p>	<ul style="list-style-type: none"> ■ ■ - change the oil separating filter, Chapter 23

19.2 TROUBLE-SHOOTING AND EMERGENCY REMEDIES FOR DRYER



ALL WORK MUST BE CARRIED OUT BY PROFESSIONALLY SKILLED PERSONNEL. BEFORE CARRYING OUT ANY MAINTENANCE JOBS IT IS MANDATORY TO STOP THE MACHINE AND DISCONNECT IT FROM THE POWER SUPPLY.

N.B. OPERATIONS MARKED ■ ■ MUST BE CARRIED OUT BY PROFESSIONALLY SKILLED PERSONNEL AUTHORISED BY THE MANUFACTURER

FAULT FOUND	POSSIBLE CAUSES	OBSERVATIONS
1) No compressed air passes through the dryer outlet	1A) The pipes are frozen inside	<p>■■ -The bypass valve of the hot gas is broken or out-of-calibration</p> <p>-The room temperature is too low and the evaporators piping are obstructed with ice</p>
2) Presence of condensate in the pipings.	<p>2A) The condensate separator does not work correctly</p> <p>2B) The dryer is working outside its rating</p> <p>2C) The dryer is working under bad conditions of condensation</p>	<p>■■ -Check the solenoid exhaust valve</p> <p>■■ -Check the drainage timer</p> <p>-Check the flow rate of treated air</p> <p>-Check the room temperature</p> <p>-Check the air temperature at the drier inlet.</p> <p>-Clean the condenser.</p> <p>■■ -Check the good operation of the fan.</p>
3) The compressor head is very hot (> 55 °C)	<p>Make reference to 2B</p> <p>Make reference to 2C</p> <p>3A) The cooling circuit is not working with the right gas charge</p>	<p>■■ -Check if there are leaks of refrigerating gas.</p> <p>■■ - Charge it again.</p>
4) Motor cuts out on overload	<p>Make reference to 2B</p> <p>Make reference to 2C</p> <p>Make reference to 3A</p>	
5) The motor hums and does not start.	<p>The line voltage is too low.</p> <p>You switched the machine off and on again without leaving enough time for the pressure balancing.</p> <p>The starting system of the motor is defective.</p>	<p>-Contact the electric power company</p> <p>-Wait a few minutes before starting the machine again.</p> <p>■■ -Check the running and starting relays and condensers (if any)</p>
6) The compressor is very noisy.	Troubles with the internal mechanical parts or with the valves	

PART "B"



THIS PART "B" OF THE INSTRUCTIONS MANUAL IS RESERVED FOR PROFESSIONALLY SKILLED PERSONNEL AUTHORISED BY THE MANUFACTURER.

20.0 STARTING UP



BEFORE CARRYING OUT ANY OPERATION ON THE MACHINE, ENSURE THAT THE ELECTRIC POWER SUPPLY HAS BEEN DISCONNECTED.

20.1 PREPARING FOR SETTING UP (FIG.24)

After checking everything as indicated in Chap. 12, follow the instructions in Fig. 24.

- Fit the sound-absorbing panels Ref. 1 Fig. 24
- These parts are packed in the bodywork.

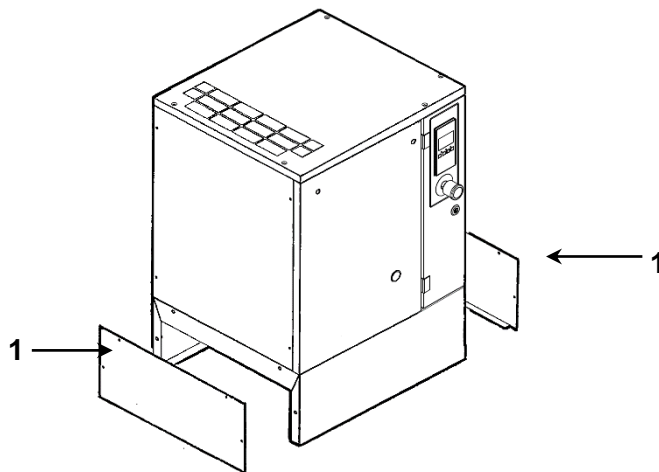

FIG. 24

20.2 PRELIMINARY CHECKS

Check the oil level Ref. 1 Fig. 25; when delivered, the machine is filled with oil, if the oil level is not as intended, top up with the same oil as the original type (use the procedure in the chapter 15.3).

If more than 3 months have passed between the inspection in the factory and the date of installation, lubricate the screw group before starting up, following the procedure described below:

- Remove the protection Ref. 2 Fig. 25
- Remove the fixed protection device (machine cover) Ref. 3 Fig. 25.
- Remove the cover Ref. 4 Fig. 25
- Remove the air filter Ref. 5 Fig. 25
- Pour a little oil into the suction unit.
- Reassemble the air filter Ref. 5 Fig. 25
- Reassemble the cover Ref. 4 Fig. 25

If more than 6 months have passed between the inspection in the factory and the date of installation, consult the manufacturer.

20.3 STARTING THE DRYER (FIG.25)

Start the dryer before turning on the compressed air.

The compressed air piping will be free of condensate only by doing so.

The dryer must be kept running during all the time the air compressor is running. **WARNING:** if the dryer is switched off, before starting it again, wait at least 5 minutes in order to allow the pressure balancing.

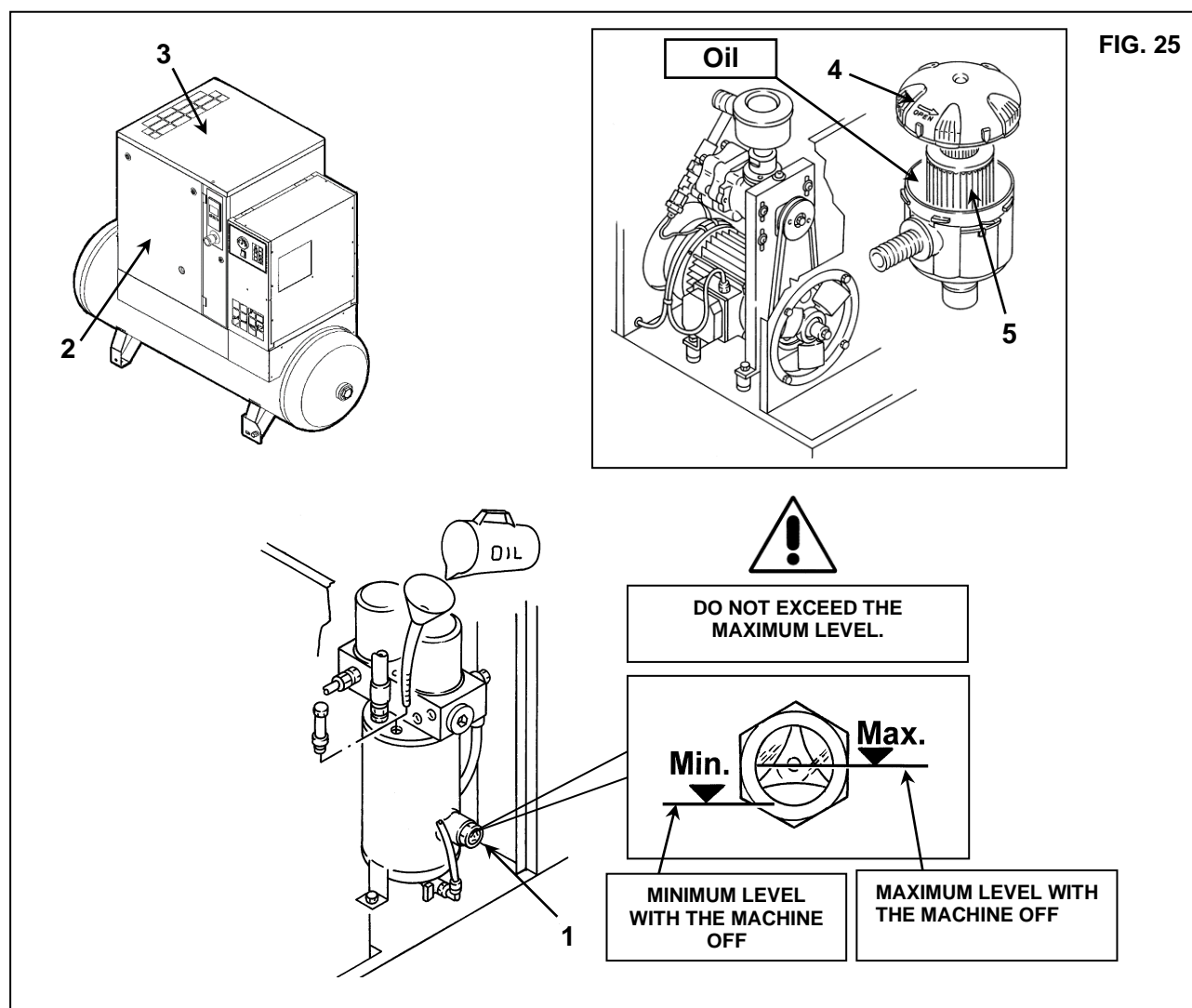

20.4 CHECK THE COMPRESSOR ROTATION DIRECTION AND START UP (FIG.26)

- Check that all the protective shields are in place.
- Apply voltage to the control panel by operating the automatic differential switch of the line Ref. 1 Fig. 26.
- Switch on the compressor pressing start/stop button for 3 seconds. Immediately after 1s, stop the compressor acting on the emergency stop button.
- **If the rotation is correct, the paper sheet Ref. 3 is blown up (See Fig. A)**
- **If the rotation is not correct, the paper sheet remains flat (See Fig. B) PHASE INCORRECT**



ALL WORK ON THE ELECTRIC PLANT, HOWEVER SLIGHT, MUST BE CARRIED OUT BY PROFESSIONALLY SKILLED PERSONNEL.

- Disconnect the energy supply and invert two connections as per Ref. 1 Fig. B.

IT IS ADVISABLE NOT TO DO ANYTHING ON THE MACHINE PANEL.

IF ALL THE INSTRUCTIONS FOUND IN THIS MANUAL HAVE BEEN OBSERVED THE MACHINE CAN BE STARTED.

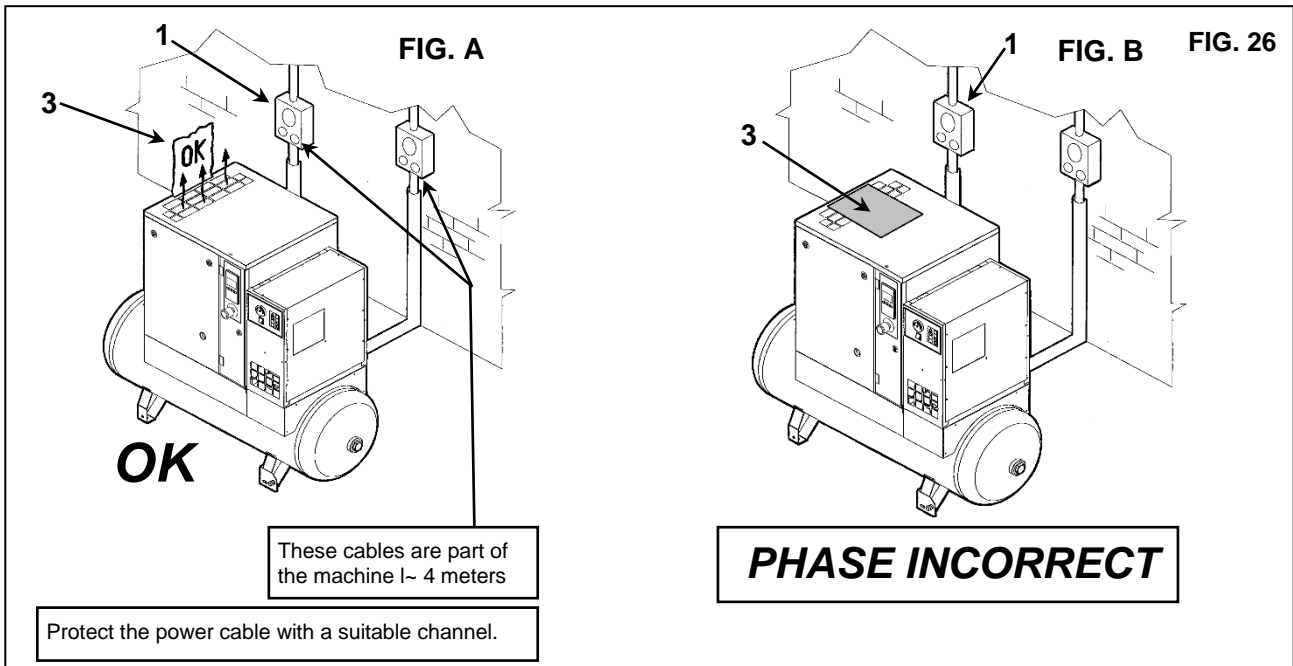

21.0 GENERAL ORDINARY MAINTENANCE REQUIRES TRAINED PERSONNEL



BEFORE CARRYING OUT ANY MAINTENANCE JOBS IT IS OBLIGATORY TO STOP THE MACHINE AND DISCONNECT IT FROM THE POWER MAINS.

MAINTENANCE SCHEDULE

- OPERATIONS THAT MAY BE CARRIED OUT BY THE USER
- ■ OPERATIONS THAT REQUIRE SKILLED PERSONNEL; THESE OPERATIONS ARE ILLUSTRATED IN PART "B" OF THIS MANUAL.

The indicated oil exchange intervals are valid for standard operating conditions and nominal operating. Exposure of the compressor to external pollutants or operation at high humidity combined with low duty cycles may require a shorter oil exchange interval. Contact your supplier if in doubt.

Every Day (after use)	<ul style="list-style-type: none"> ■ Drain the condensate from the air tank ■ Check the automatic drainage of the condensate (dryer)
Every 50 working hours (or at least weekly)	<ul style="list-style-type: none"> ■ Drain condensate from the oil tank ■ Check the oil level ■ Clean the filtering panel
Every 500 hours (or at least every 3 months)	<ul style="list-style-type: none"> ■ Clean the air suction filter ■ Clean the condenser battery (on the dryer if fitted) ■ Clean the filter of the automatic condensate drain ■ ■ Check belt tension
Every 2000 hours (or at least every 1 year)	<ul style="list-style-type: none"> ■ Change the suction filter ■ ■ Change the oil ■ ■ Change the oil filter ■ ■ Check belt tension and adjust or change if necessary ■ ■ Replace the filter of automatic condensate drain (2902016102) ■ ■ Clean the finned surface of the air-oil cooler ■ ■ Safety temperature test ■ ■ Retighten all power cable connections
Every 4000 hours (or at least every 2 years)	<ul style="list-style-type: none"> ■ ■ Change the filtering panel (black foam) ■ ■ Change the oil separating filter ■ ■ Replace drain kit (2200902017) ■ ■ Replace the belts
Every 6000 hours (or at least every 3 years)	<ul style="list-style-type: none"> ■ ■ Service kit for the inlet valve. ■ ■ Replace the electronic drain. ■ ■ Service kit minimum pressure valve and thermostatic valve

22.0 CHANGING THE OIL (FIG. 27)

CAUTION: THIS OPERATION MUST BE DONE TOGETHER WITH THE OIL FILTER AND AIR FILTER EXCHANGE



BEFORE CARRYING OUT ANY MAINTENANCE JOBS IT IS OBLIGATORY TO STOP THE MACHINE AND DISCONNECT IT FROM THE POWER MAINS AND FROM THE COMPRESSED AIR DISTRIBUTION NETWORK.

Oil changing is an important operation for the compressor: if the lubrication of the bearings is not efficient, the compressor life will be short.

The oil must be changed when the machine is still warm, that is immediately after stopping it.

The suggestions listed below should be scrupulously followed.

After draining the old oil out of the machine Ref. 1 Fig. 27.

- Fill the oil manifold Ref. 2 Fig. 27 up to the level mark
- Pour a drop of oil into the intake unit, as described in CHAP. 20.1
- Close all the protections (cover and front protection) Ref. 3 Fig. 27
- Start the compressor.
- After about 1 minute, stop the machine.

PROCEED AS DESCRIBED AT CHAPTER 15.3

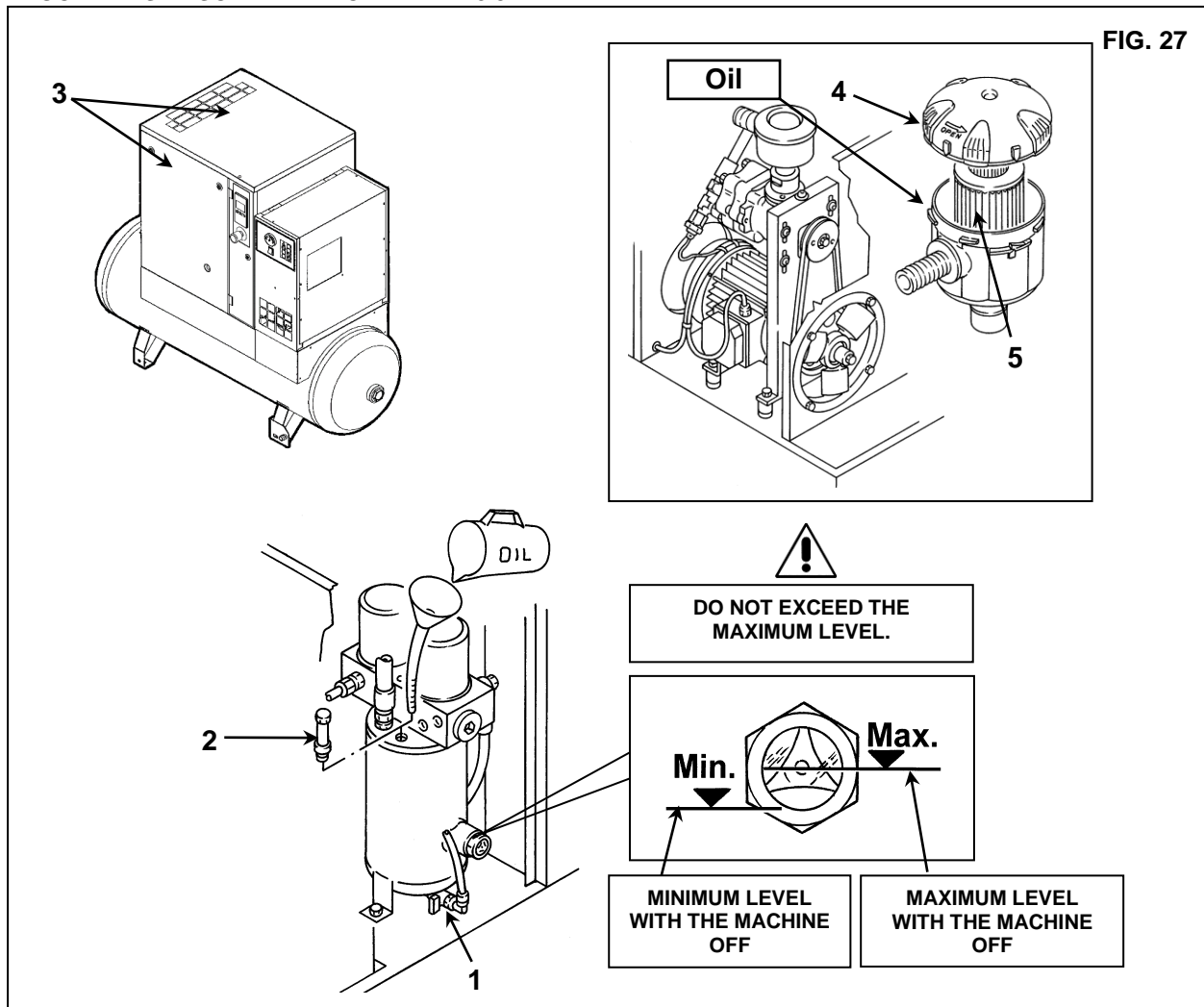

THE OLD OIL MUST BE DISPOSED OF IN COMPLIANCE WITH THE REGULATIONS IN FORCE.

NOTE ON LUBRICANTS

When delivered the machine is filled with oil.

In normal conditions of use, these lubricants have proved to be able to withstand use for as many as 4.000 hours. However, due to the external polluting agents that get into the compressor with the air that it takes in, it is advisable to change the oil at more frequent intervals, as indicated on the routine maintenance chart.

If the compressor is being used at high temperatures (continuous operation above 90 °C) or in particularly severe conditions, we advise changing the oil at shorter intervals than those recommended in the maintenance chart.

DO NOT TOP UP WITH DIFFERENT OILS

23.0 REPLACE THE OIL SEPARATOR FILTER AND THE OIL FILTER (FIG. 27)

BEFORE CARRYING OUT ANY MAINTENANCE THE MACHINE MUST BE STOPPED, CUT OFF THE MACHINE FROM THE ELECTRICAL MAINS AND FROM THE COMPRESSED AIR DISTRIBUTION CIRCUIT, CHECK THAT THE MACHINE IS NOT UNDER PRESSURE.

N.B. INTERNAL PRESSURE IS AUTOMATICALLY DISCHARGED AFTER ABOUT 30 SECONDS WHEN THE MACHINE IS TURNED OFF

Proceed as follows:

- Open the front panel Ref. 1 Fig. 28 with the special key.
- Remove the fixed protection device (machine cover) Ref. 2 Fig. 28.
- Remove the oil separation filter Ref. 3 and oil filter Ref. 4 Fig. 28.
- Lubricate the filter seals with a little oil before fitting.
- Tightening must be done by hand.
- Close the fixed protection (machine cover) Ref. 2 Fig. 28 device again, using the appropriate safety screws.
- Close the panel Ref. 1 Fig. 28.

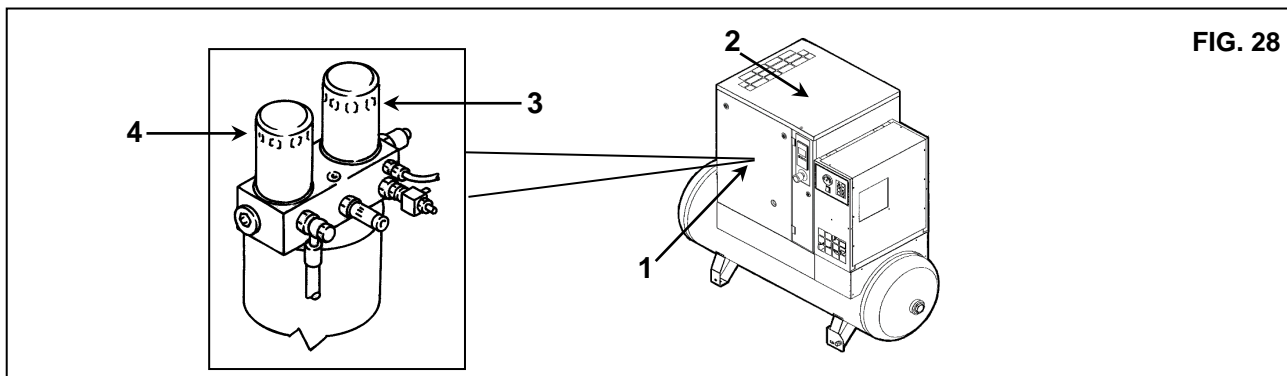

FIG. 28

24.0 BELT TENSION (HP 3-4-5,5-7,5-10 / kW 2,2-3-4-5,5-7,5) (FIG. 29)

BEFORE CARRYING OUT ANY MAINTENANCE THE MACHINE MUST BE STOPPED, CUT OFF THE MACHINE FROM THE ELECTRICAL MAINS AND FROM THE COMPRESSED AIR DISTRIBUTION CIRCUIT, CHECK THAT THE MACHINE IS NOT UNDER PRESSURE.

Tightening or retightening new belts

Proceed as follows:

- Open the front panel Ref. 1 Fig. 29 with the special key.
- Remove the fixed protections device Ref. 2, 3, 4 Fig. 29.
- Loose the screws by half a turn Ref. 5 Fig. 29.
- Adjust the belt tension by turning the screws Ref. 6 Fig. 29
- Close the screws again Ref. 5 (***) Fig. 29.
- The belt tensioning values are indicated with a label on the element-motor frame. The force and deflection varies with the power of the unit, and with the total running hours of the belt.
- Close the fixed protections Ref. 2, 3, 4 Fig. 29 device again, using the appropriate safety screws.
- Close the panel Ref. 1 Fig. 29.

25.0 REPLACING THE BELT (HP 3-4-5,5-7,5-10 / kW 2,2-3-4-5,5-7,5) (FIG. 29)

BEFORE CARRYING OUT ANY MAINTENANCE THE MACHINE MUST BE STOPPED, CUT OFF THE MACHINE FROM THE ELECTRICAL MAINS AND FROM THE COMPRESSED AIR DISTRIBUTION CIRCUIT, CHECK THAT THE MACHINE IS NOT UNDER PRESSURE.

Proceed as follows:

- Open the front panel Ref. 1 Fig. 29 with the special key.
- Remove the fixed protections device Ref. 2, 3, 4 Fig. 29.
- Remove the internal support oil cooler (n°3 screws M6).
- Loose the screws by half a turn Ref. 5 Fig. 29.
- Release belt tension by unscrewing the screw Ref. 6 (2X) Fig. 29.
- Dismantle and remove the belt Ref. 9 Fig. 29 and fit the new belt following the instructions in reverse order.
- **To set belt tension, proceed as given in Chap. 24.0.**
- Reassemble the internal support oil cooler (n°3 screws M6).
- Reassemble the permanent protections Ref. 2, 3, 4 Fig. 29 fixing them in place with the special safety screws
- Close the panel Ref. 1 Fig. 29.

HP 3-4-5,5-7,5-10 / kW 2,2-3-4-5,5-7,5

FIG. 29

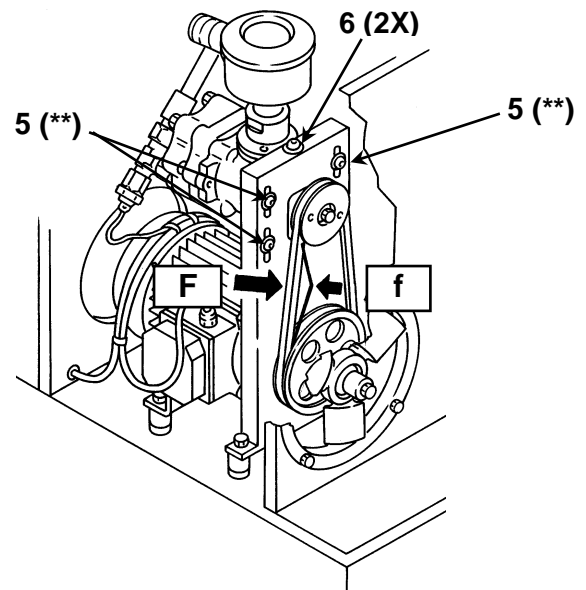
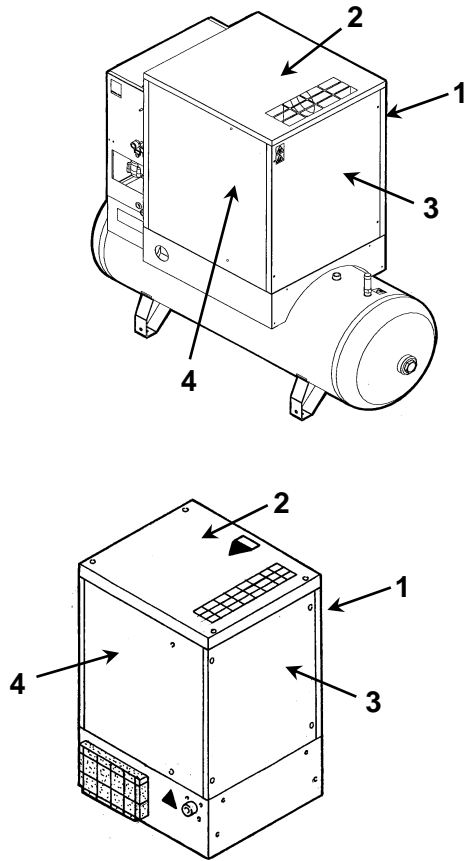

(**) Tightening torque = 25 N•m

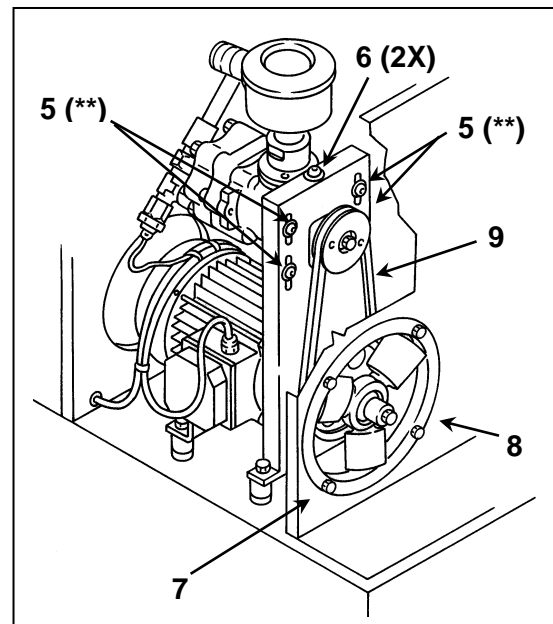

1 - F = 5 kg., force to be applied at the centre line, at right angles to the new belt.
 2 - f = 6 mm., clearance after the application of F. (after 100 h operation F = 3 kg.)

26.0 CIRCUIT DIAGRAM

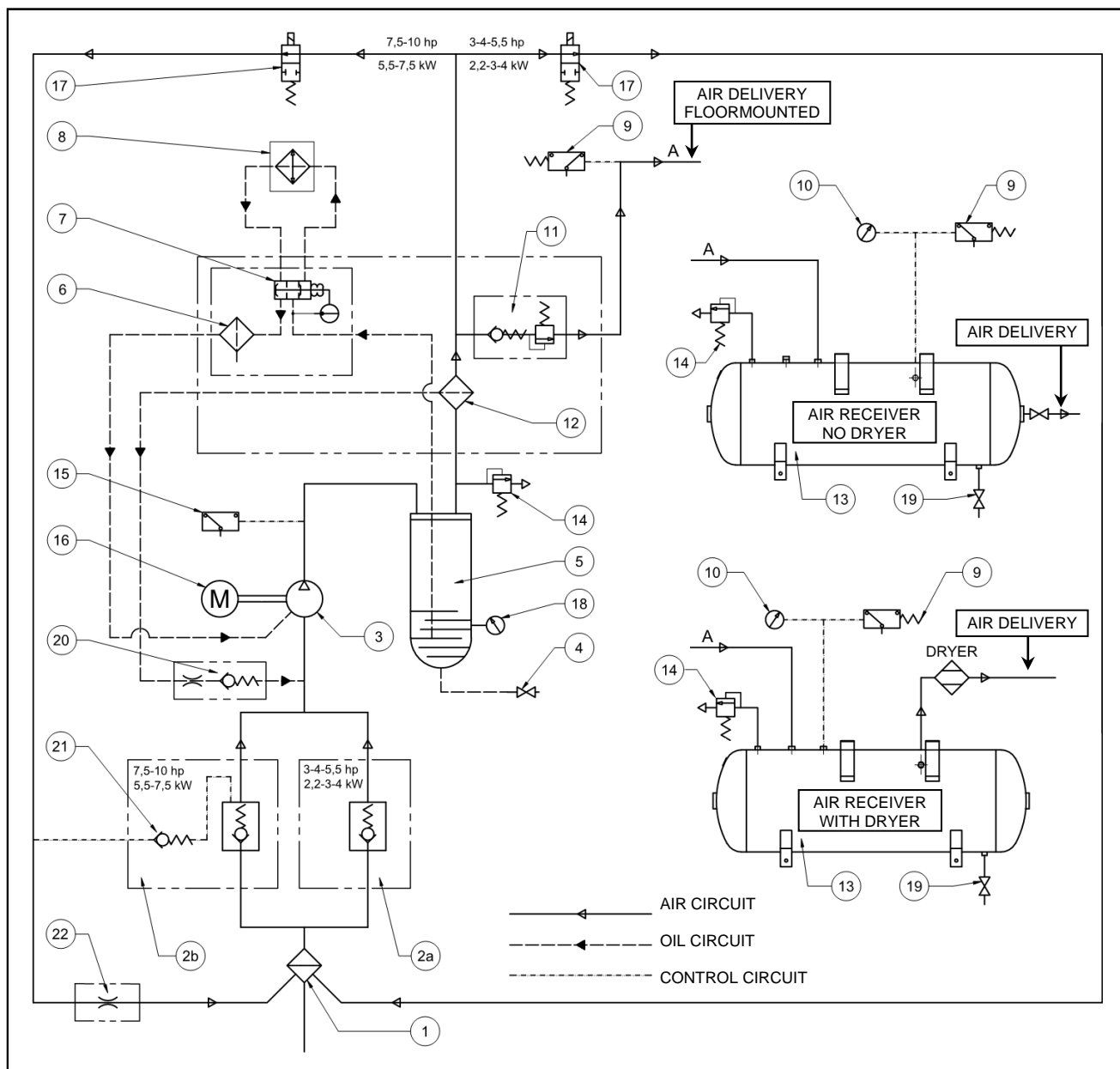

- | | |
|--|---|
| 1 SUCTION AIR FILTER | 11 MINIMUM PRESSURE VALVE |
| 2a SUCTION REGULATOR (CHECK VALVE) (3-4-5,5 HP / 2,2-3-4 kW) | 12 AIR-OIL SEPARATOR ELEMENT |
| 2b SUCTION REGULATOR (UNLOADER) (7,5-10 HP / 5,5-7,5 kW) | 13 AIR RECEIVER |
| 3 OIL INJECTION SCREW COMPRESSOR ELEMENT | 14 SAFETY VALVE |
| 4 OIL DRAIN VALVE | 15 TEMPERATURE SWITCH (EP)
TEMPERATURE SENSOR (BC) |
| 5 AIR/OIL RECEIVER | 16 DRIVE MOTOR |
| 6 OIL FILTER | 17 SOLENOID VALVE |
| 7 THERMOSTATIC VALVE | 18 SIGHT OIL LEVEL |
| 8 OIL COOLER | 19 VALVE PURGE AIR RECEIVER |
| 9 PRESSURE SWITCH (EP)
PRESSURE SENSOR (BC) | 20 NON-RETURN VALVE AND NOZZLE |
| 10 PRESSURE GAUGE (EP)
COMPRESSOR CONTROLLER (BC) | 21 NON-RETURN VALVE (7,5-10 HP / 5,5-7,5 kW) |
| | 22 NOZZLE (7,5-10 HP / 5,5-7,5 kW) |

(EP) ELECTRO PNEUMATIC VARIANT
(BC) BASE CONTROLLER VARIANT

27.0 CALIBRATION FOR DRYER

BYPASS VALVE FOR HOT GAS

N.B. These valves have already been calibrated and they do not require any adjustment. A dew point different from the rated one generally depends on causes which are not attributable to their operation.

- 1) Closing cap
- 2) Adjusting screw

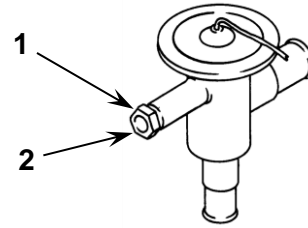

WORKING PRESSURES AND TEMPERATURES OF R513A

SUCTION SIDE OF REFRIGERATION COMPRESSOR		
	Evaporating Temp. (°C)	Evaporating Pressure (bar)
RATED VALUES (Temp. 20 °C)	1 ÷ 2	R513A 2,35 ÷ 2,47

27.1 FLOW DIAGRAM OF THE DRYER

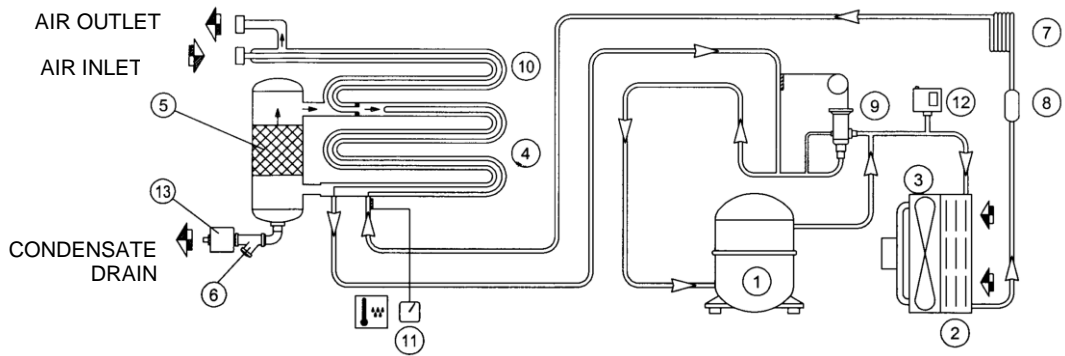

- 1 REFRIGERANT COMPRESSOR
- 2 GAS CONDENSER
- 3 FAN MOTOR
- 4 HEAT EXCHANGER
- 5 DEMISTER CONDENSATE SEPARATOR
- 6 IMPURITY TRAP
- 7 CAPILLARY TUBE
- 8 REFRIGERATION FLUID FILTER
- 9 HOT GAS BYPASS VALVE
- 10 AIR-TO-AIR EXCHANGER
- 11 DEW POINT THERMOMETER/CONTROLLER
- 12 FAN PRESSURE SWITCH
- 13 ELECTRONIC CONDENSATE DRAIN