



Spareparts



BANDSCHUURMACHINES

BS 75/2000 W

BS 75/2000 D

BS 150/2000 D

9

- NL** Onderdelen en schakelschema
- FR** Pièces détachées et schéma électrique
- EN** Spare parts and electrical drawing

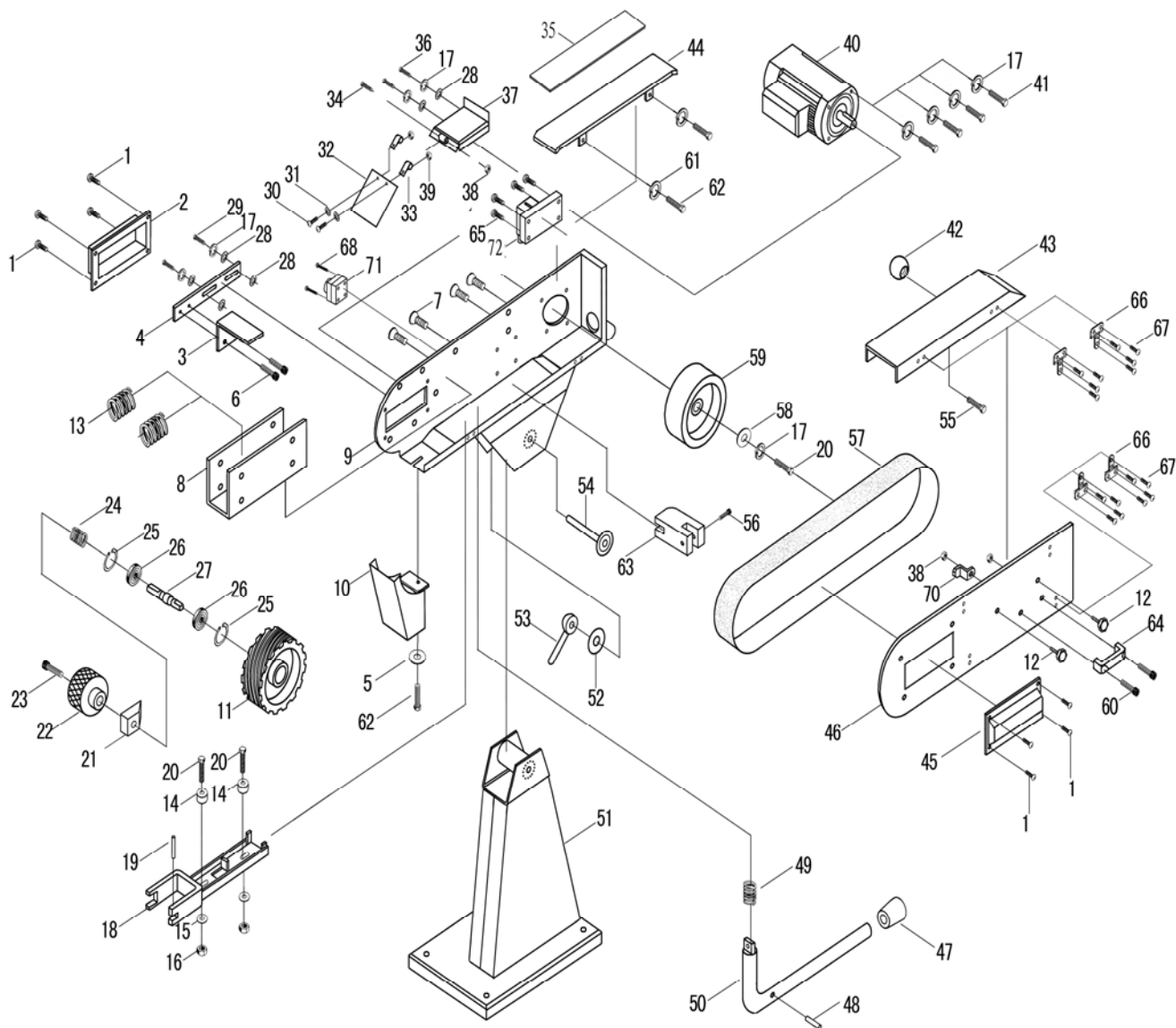

PART NO.	DESCRIPTION	QTY	REMARKS	PART NO.	DESCRIPTION	QTY	REMARKS
1	CUP HEAD SCREW M4X6	8		31	FLAT WASHER Φ 4	2	
2	LEFT COVER	1		32	PERSPECTIVE PLATE	1	
3	WORK TABLE	1		33	COLLECTING BOARD	2	
4	FIXATION BOARD OF WORK TABLE	1		34	CUP HEAD SCREW M6X50	1	
5	FLAT ASHER Φ 8	1		35	BLACK LEAD PLATE	1	
6	HEXAGON SOCKET COUNTERSUNK HEAD SCREW 8*10	2		36	BOLT M8X12	2	
7	HEXAGON SOCKET COUNTERSUNK HEAD SCREW 8*16	4		37	FENCE EXTENSIONS	1	
8	U-SUPPORT	1		38	SELF-LOCKING NUT M6	2	
9	BODY	1		39	NUT M4	2	
10	DUST RECEIVER	1		40	MOTOR	1	
11	DRIVEN WHEEL	1		41	BOLT M8X25	4	
12	STAR GRIP SCREW	3		42	HAND BALL	1	
13	SPRING	2		43	SAFETY COVER	1	
14	FLAT WASHER Φ 8	2		44	TOP TABLE	1	
15	FLAT FASHER Φ 8	6		45	RIGHT COVER	1	
16	SELF-LOCKING NUT M8	2		46	SIDE FENCE	1	
17	NUT M8	2		47	PROPECT TUBE	1	
18	DRIVEN WHEEL GUIDE	1		48	PIN 3X20	1	
19	COLUMNAR PIN Φ 6X50	1		49	SPRING	1	
20	BOLT M8X25	4		50	HAND BAR	1	
21	SHAFT BLOCK	1		51	BASE	1	
22	HAND WHEEL	1		52	WASHER	1	
23	HEXAGONAL SOCKET SCREW M6X30	1		53	LOCK KNOB	1	
24	SPRING	1		54	LOCK SHAFT	1	
25	RETAINING RING Φ 47	2		55		1	
26	BEARING 204	2		56	HEXAGONAL SOCKET SCREW M5X20	1	
27	DRIVEN WHEEL SHAFT	1		57	SAND BELT	1	
28	FLAT WASHER Φ 8	5		58	BIG WASHER Φ 32	1	
29	BOLT M8X25	2		59	DRIVE WHEEL	1	
30	CUP HEAD SCREW M4X10	2		60	CUP HEAD SCREW M8X20	2	

PART NO.	DESCRIPTION	QTY	REMARKS	PART NO.	DESCRIPTION	QTY	REMARKS
61	ELASTIC WASHER $\phi 8$	2		67	CUP HEAD SCREW M4X6	16	
62	BOLT M8X12	2		68	SCREW M4X15	2	
63	HAND BAR COLLECTING ROD	1		69	SCREW M4X30	4	
64	HANDLE	1		70	SPRING PLATE	1	
65	SCREW M4X30	4		71	EMERGENCY SWITCH	1	
66	HINGE	4		72	SWITCH	1	

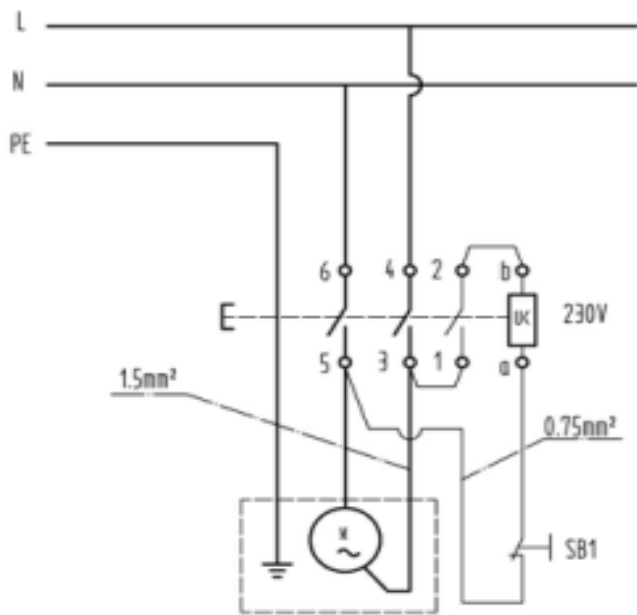

1 PHASE - 230 V - 50 Hz

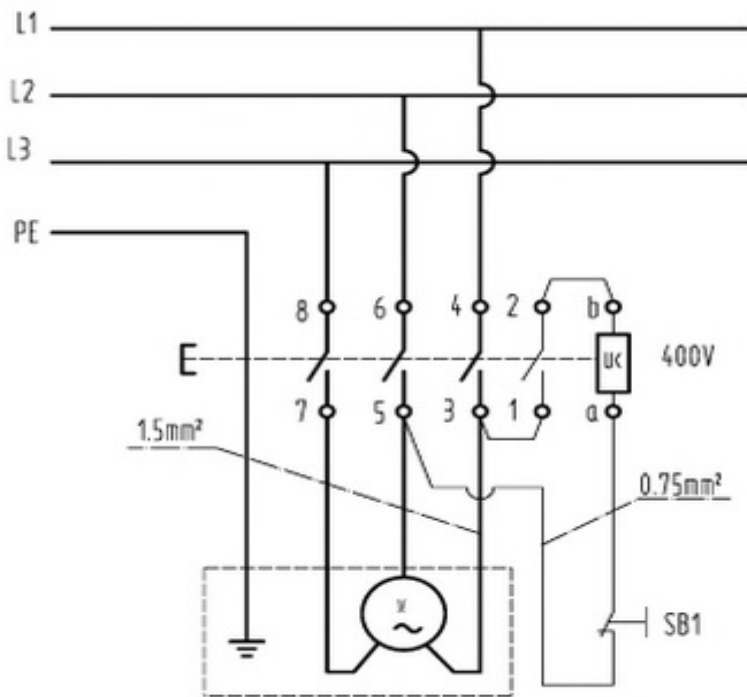

1 PHASE - 400 V - 50 Hz

No.	Code	Part	Type	Specification	Manufacturer	Approval
1		Cable	H07RN-F	4*1.5mm ²	HELUKABEL	TUV
2		Metric bushing	HSK-Flex	PG9 M16X1.5	HUMMEL	VDE
3		Internal wire	AVLV8		Wuxi Baiyun Wire&Cable Co., Ltd.	UL