

tielbürger®

- Ⓚ Ersatzteilliste
- ⓕ Pièces détachées
- ⓐ Spare parts list
- Ⓛ Lista ricambi
- Ⓝ Deleliste

Copyright © 2011 by Julius Tielbürger GmbH & Co. KG, Stemwede Nachdruck, auch auszugsweise nicht gestattet. KR-330-046TS 02/2018-1

tk18



Julius Tielbürger GmbH & Co. KG Maschinenfabrik
Postdamm 12 D-32351 Stemwede-Oppenwehe Tel.: +49 (0) 57 73/80 20 Fax: +49 (0) 57 73/81 75
Internet: www.tielbuerger.de

Inhaltsverzeichnis

Kehrbürste	2
Brosse	
Brush	
Spazzole	
Børstedrift	
Achse	4
Arbre	
Axle	
Asse	
Aksel	
Motor	6
Moteur	
Motor	
Motore	
Motor	
Gehäuse	10
Boite	
Housing	
Scatola	
Hus	
Getriebehalter	12
Support d'entraînement	
Gear stud	
Supporto trasmissione	
Gearholder	
Bodenblech	14
Fond en tôle	
Bottom plate	
Lamierino	
Deksel	
Stützrad	18
Rouesupport	
Supporting wheel	
Ruota supporto	
Hjul	
Lenker	20
Mancheron	
Handle bars	
Manubrio	
Styre	

WICHTIG!

Die Spalte „Bemerkung“ hilft Ihnen, Teile zu identifizieren.

Verwenden Sie ausschließlich Originalersatzteile vom Hersteller. Dadurch wird die sichere Funktion des Gerätes gewährleistet.

Positionsnummern in Klammern sind Verschleißteile.

NOTE!

The column labelled „Comments“ is to help you in identifying parts.



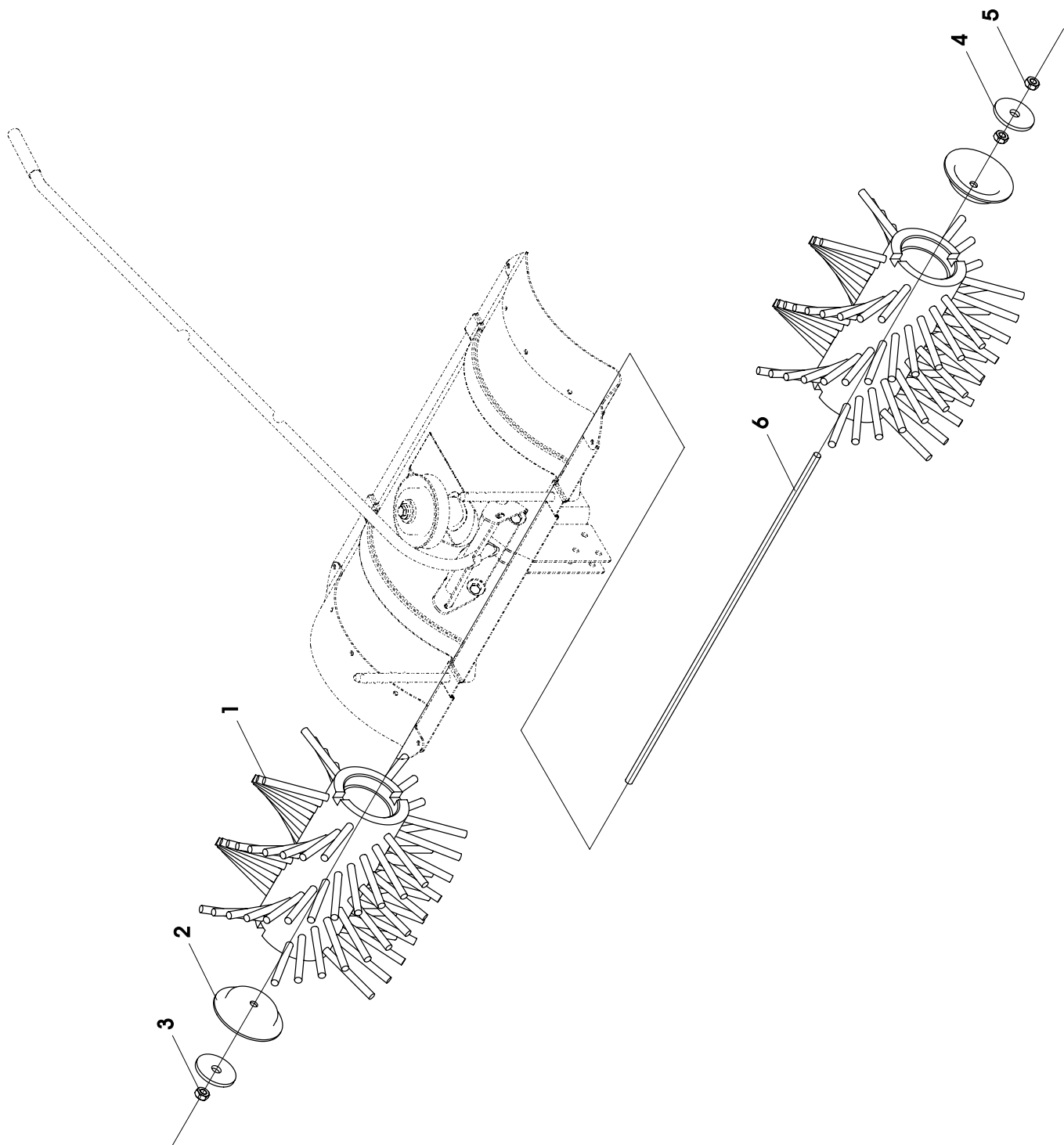

Only use genuine replacement parts from the manufacturer. These will ensure that the machine functions correctly.

Item numbers in parentheses are parts that are subject to wear.

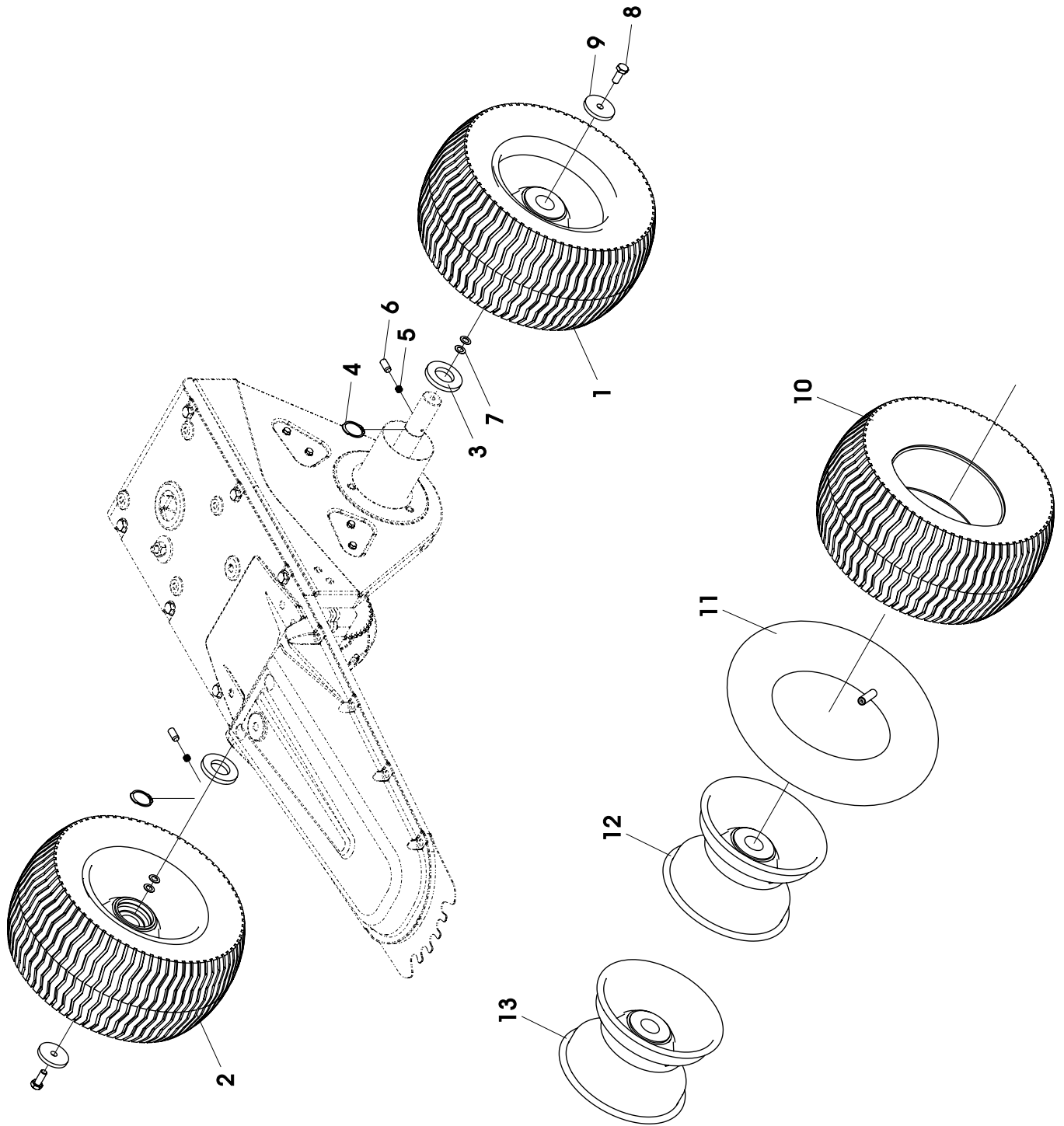

Pos.-Nr. Rep.	Bestellnummer Réfèrence	Anzahl Qté.	Bezeichnung	Désignation	Description	Descrizione	Benevnelse	Bemerkung Remarque Remarks Osservazione Bemerkninger
Pos. Bilde-Nr.	Article number Nr. codice Bestillings-Nr	Quant. Q.tà Antall	(D)	(F)	(GB)	(I)	(N)	
(1)	AD-090-080	2	Kehrbürste	Paire de brosses	Pair of brushes	Set spazzole	Børste	
2	DA-241-043z	2	Kappe	Couvercle	Cap	Coperchietto	Kapp	
3	HR-030-006z	1	Sicherungsmutter	Écrou de sûreté	Locknut	Dado autobloccante	Låsemutter	M10
4	DA-332-007	2	Scheibe	Rondelle	Washer	Rondella	Skive	
5	HR-010-006z	2	Sechskantmutter	Écrou à six pans	Hexagon nut	Dado esagonale	Sekskantmutter	M 10
6	DC-080-077z	1	Achse	Arbre	Axle	Asse	Aksel	





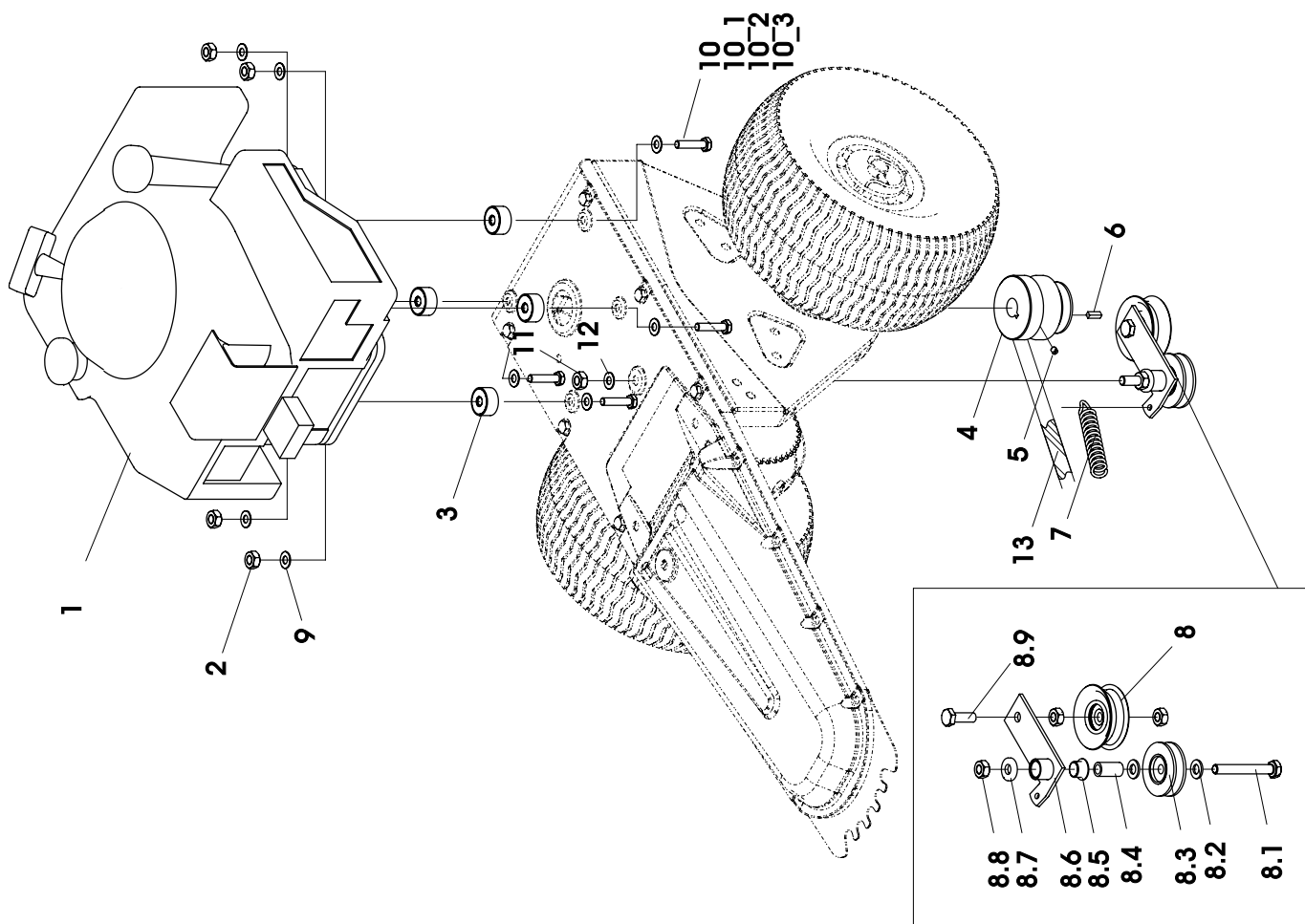

Pos.-Nr. Rep.	Bestellnummer Référéce	Anzahl Qté.	Bezeichnung	Désignation	Description	Descrizione	Benevnelse	Bemerkung Remarque Remarks Osservazione Bemerkninger
Pos. Pos. Bilde-Nr.	Article number Nr. codice Bestillings-Nr	Quant. Q.tà Antall						
(1)	AD-390-050TS	1	Rad links kpl.	Roue gauche	Wheel left	Ruot sx sinistro (a)	Hjul venstre	
(2)	AD-390-051TS	1	Rad rechts kpl.	Roue droite	Wheel right	Ruot dx destro (a)	Hjul høyre	
3	DA-352-031z	2	Scheibe	Rondelle	Washer	Rondella	Skive	
4	HU-010-025	2	Sicherungsring	Anneau d'arrêt	Retaining ring	Sege	Semering	A25x1,2
(5)	HI-020-015	2	Druckfeder	Ressort de pression	Compression spring	Molla di compressione	Fjær	
6	HX-020-220	2	Zylinderstift	Goupille de cylindre	Lowel pin	Spina cilindro	Rørsplint	8x18
7	HW-080-116	4	Paßscheibe	Rondelle	Shaft spacer	Anello distanziale	Skive	8x14x0,5
8	HO-020-083z	2	Sechskantschraube	Vis à six pans	Hexagon bolt	Vite esagonale	Sekskantskrue	M8x20
9	DA-332-307z	2	Scheibe	Rondelle	Washer	Rondella	Skive	
(10)	HN-022-013	1	Decke	Enveloppe	Tire Cover	Coperchio	Dekk	
11	HN-032-010	1	Schlauch	Outre	Tube	Camera aria	Slange	
(12)	AD-390-101p9010	1	Felge links	Jante gauche	Rim/Hub left	Cerchio sx sinistro (a)	Felg venstre	
(13)	AD-390-102p9010	1	Felge rechts	Jante droite	Rim/Hub right	Cerchio dx destro (a)	Felg høyre	

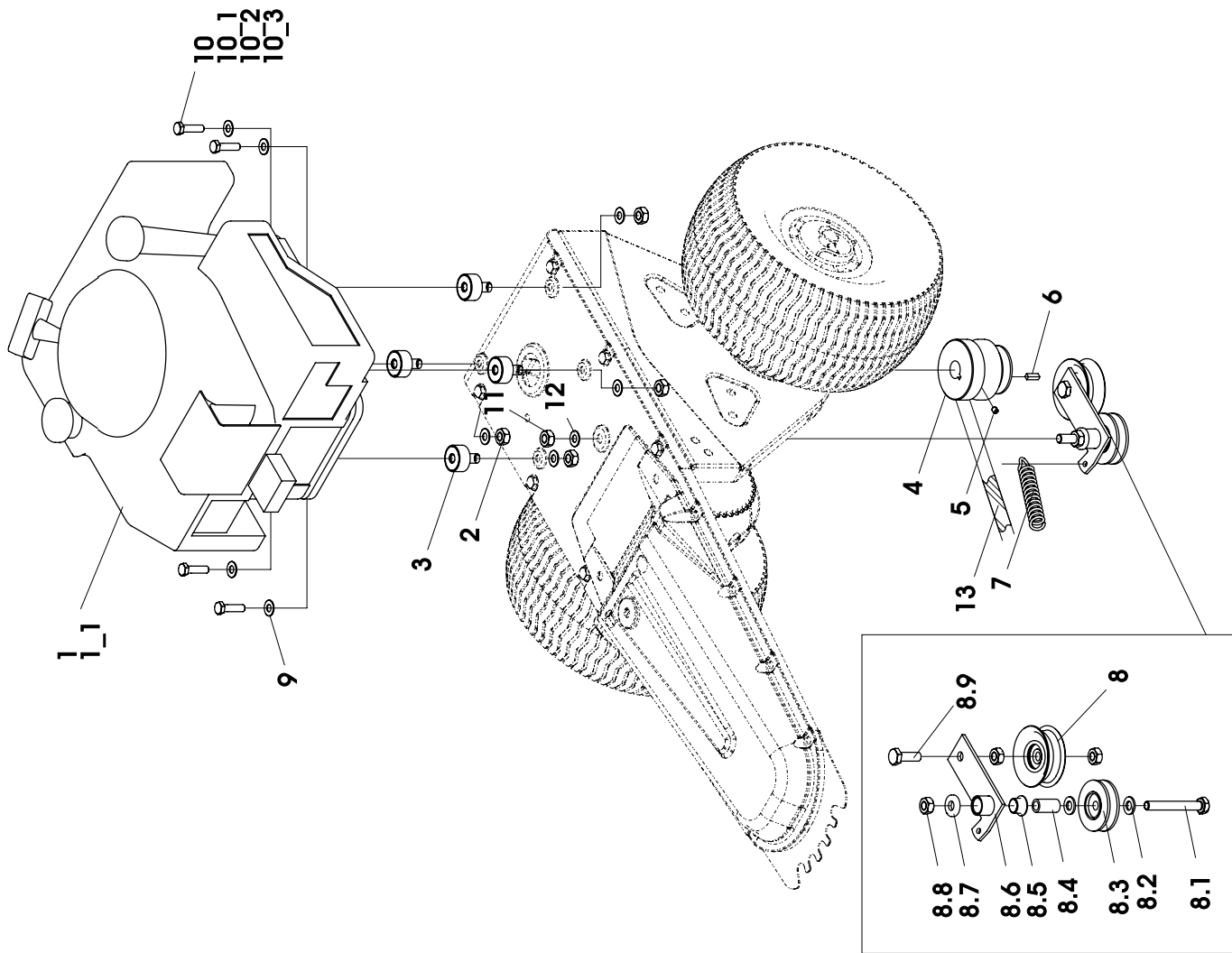

Pos.-Nr. Rep.	Bestellnummer Référéce	Anzahl Qté.	Bezeichnung	Désignation	Description	Descrizione	Benevnelse	Bemerkung Remarque
Pos.	Article number	Quant.						Remarks
Pos.	Nr. codice	Q.tà						Osservazione
Bilde-Nr.	Bestillings-Nr	Antall						Bemerkninger
(1)	KA-008-011	1	Motor B&S	Motor	Motor	Motore	Motor	
2	HR-010-005z	3	Sechskantmutter	Écrou à six pans	Hexagon nut	Dado esagonale	Sekskantmutter	M8
3	DC-181-092z	3	Hülse	Douille	Spacer tube	Boccola	Hylse	
(4)	DX-001-096e	1	Keilriemenscheibe	Poulie	Vbelt pulley	Puleggia	Kileremskive	
5	HP-022-051z	1	Gewindestift	Cheville	Slotted set screw	Spina filettata	Gjengestift	M6x8
6	KH-020-102	1	Zollpaßfeder	Ressort au pouce	Parallel key	Linguetta in pollici	Kile	
7	HI-010-003-9005	1	Zugfeder	Ressort de traction	Extension spring	Molla di trazione	Fjær	
(8)	AZ-002-001	1	Spannrolle	Galet tendeur	Tensioning pulley	Rullo tenditore	Strammerull	
8_1	HO-010-121z	1	Sechskantschraube	Vis à six pans	Hexagon bolt	Vite esagonale	Sekskantskrue	M10x60
8_2	HW-010-009z	1	Scheibe	Rondelle	Washer	Rondella	Skive	10,5x20x2
(8_3)	AZ-002-005	1	Spannrolle	Galet tendeur	Tensioning pulley	Rullo tenditore	Strammerull	
8_4	DC-131-029z	1	Abstandshülse	Douille d'écartement	Spacer tube	Boccola distanziale	Avstandshylse	
(8_5)	HJ-021-011	1	Bundbuchse	Coussinet	Collar bush	Bussola flangiata	Foring	
8_6	AD-380-148z	1	Spanner	Tendeur	Tensioner	Tenditore	Strammer	
8_7	HW-050-009z	2	Scheibe	Rondelle	Washer	Rondella	Skive	10,4x25x4
8_8	HR-010-006z	3	Sechskantmutter	Écrou à six pans	Hexagon nut	Dado esagonale	Sekskantmutter	M10
8_9	HO-020-115z	1	Sechskantschraube	Vis à six pans	Hexagon bolt	Vite esagonale	Sekskantskrue	M10x30
9	HW-010-007z	6	Scheibe	Rondelle	Washer	Rondella	Skive	10,5x20x2
10	HO-040-089z	1	Innensechskantschraube	Vis Inbus	Allan screw	Vite brugola	Innesekskantskrue	M8x50
10_1	HO-010-090z	2	Sechskantschraube	Vis à six pans	Hexagon bolt	Vite esagonale	Sekskantskrue	M8x55 Honda
10_2	HO-010-090z	2	Sechskantschraube	Vis à six pans	Hexagon bolt	Vite esagonale	Sekskantskrue	M8x55 B&S
10_3	HO-010-091z	1	Sechskantschraube	Vis à six pans	Hexagon bolt	Vite esagonale	Sekskantskrue	M8x75 B&S
11	HW-050-009z	2	Scheibe	Rondelle	Washer	Rondella	Skive	10,5x20x2
12	HR-010-006z	1	Sechskantmutter	Écrou à six pans	Hexagon nut	Dado esagonale	Sekskantmutter	M10
(13)	HB-170-004	1	Spezial Keilriemen	Courroie	Vbelt	Cinghia	Kilerem	Antrieb





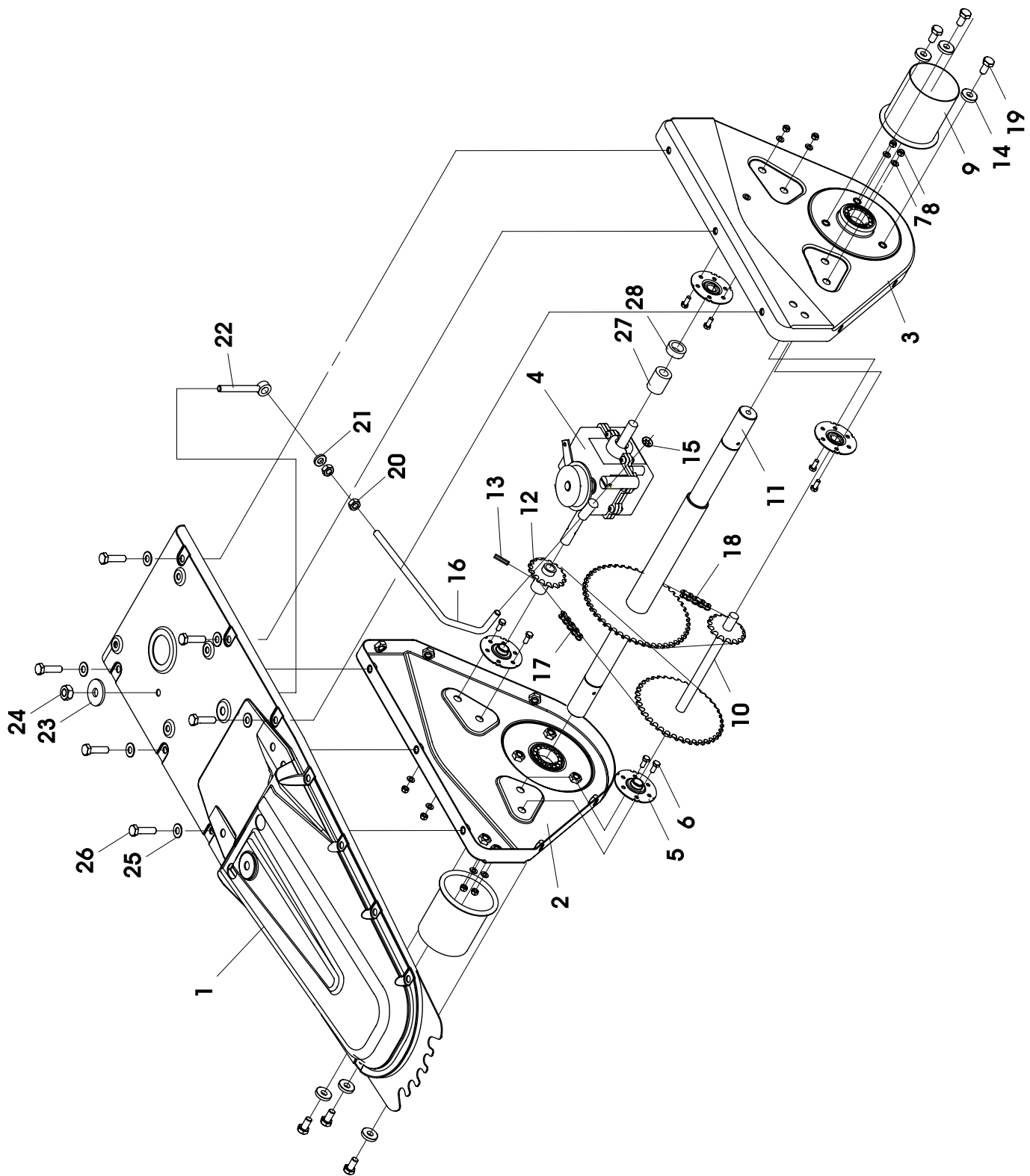

Pos.-Nr. Rep.	Bestellnummer Référéce	Anzahl Qté.	Bezeichnung	Désignation	Description	Descrizione	Benevnelse	Bemerkung Remarque Remarks Osservazione Bemerkninger
Pos. Pos. Bilde-Nr.	Article number Nr. codice Bestillings-Nr	Quant. Q.tà Antall						
(1)	KA-062-001	1	Motor Honda GCV135	Moteur	Motor	Motore	Motor	
1_1	KA-091-001	1	Motor Honda GCV160	Moteur	Motor	Motore	Motor	
2	HR-010-005z	3	Sechskantmutter	Écrou à six pans	Hexagon nut	Dado esagonale	Sekskantmutter	M8
(3)	HK-001-013	4	Gummipuffer	Patin	Bump rubber	Gomma dell'urto	Støt gummi	
(4)	DX-001-096e	1	Keilriemenscheibe	Poulie	Vbelt pulley	Puleggia	Kileremskive	
5	HP-022-051z	1	Gewindestift	Cheville	Slotted set screw	Spina filettata	Gjengestift	M6x8
6	KH-020-102	1	Zollpaßfeder	Ressort au pouce	Parallel key	Linguetta in pollici	Kile	
7	HI-010-003-9005	1	Zugfeder	Ressort de traction	Extension spring	Molla di trazione	Fjær	
(8)	AZ-002-001	1	Spannrolle	Galet tendeur	Tensioning pulley	Rullo tenditore	Strammerull	
8_1	HO-010-121z	1	Sechskantschraube	Vis à six pans	Hexagon bolt	Vite esagonale	Sekskantskrue	M10x60
8_2	HW-010-009z	1	Scheibe	Rondelle	Washer	Rondella	Skive	10,5x20x2
(8_3)	AZ-002-005	1	Spannrolle	Galet tendeur	Tensioning pulley	Rullo tenditore	Strammerull	
8_4	DC-131-029z	1	Abstandshülse	Douille d'écartement	Spacer tube	Boccola distanziale	Avstandshylse	
(8_5)	HJ-021-011	1	Bundbuchse	Coussinet	Collar bush	Bussola flangiata	Foring	
8_6	AD-380-148z	1	Spanner	Tendeur	Tensioner	Tenditore	Strammer	
8_7	HW-050-009z	2	Scheibe	Rondelle	Washer	Rondella	Skive	10,4x2,5x4
8_8	HR-010-006z	4	Sechskantmutter	Écrou à six pans	Hexagon nut	Dado esagonale	Sekskantmutter	M10
8_9	HO-020-115z	1	Sechskantschraube	Vis à six pans	Hexagon bolt	Vite esagonale	Sekskantskrue	M10x30
9	HW-010-007z	6	Scheibe	Rondelle	Washer	Rondella	Skive	8,4x21x2
10	HO-040-089z	1	Innensechskantschraube	Vis Inbus	Allan screw	Vite brugola	Innesekskantskrue	M8x50
10_1	HO-010-085z	4	Sechskantschraube	Vis à six pans	Hexagon bolt	Vite esagonale	Sekskantskrue	M8x30 Honda
10_2	HO-010-090z	2	Sechskantschraube	Vis à six pans	Hexagon bolt	Vite esagonale	Sekskantskrue	M8x55 B&S
10_3	HO-010-091z	1	Sechskantschraube	Vis à six pans	Hexagon bolt	Vite esagonale	Sekskantskrue	M8x75 B&S
11	HW-050-009z	2	Scheibe	Rondelle	Washer	Rondella	Skive	10,5x20x2
12	HR-010-006z	1	Sechskantmutter	Écrou à six pans	Hexagon nut	Dado esagonale	Sekskantmutter	M10
(13)	HB-170-004	1	Spezial Keilriemen	Courroie	Vbelt	Cinghia	Kilerem	Antrieb

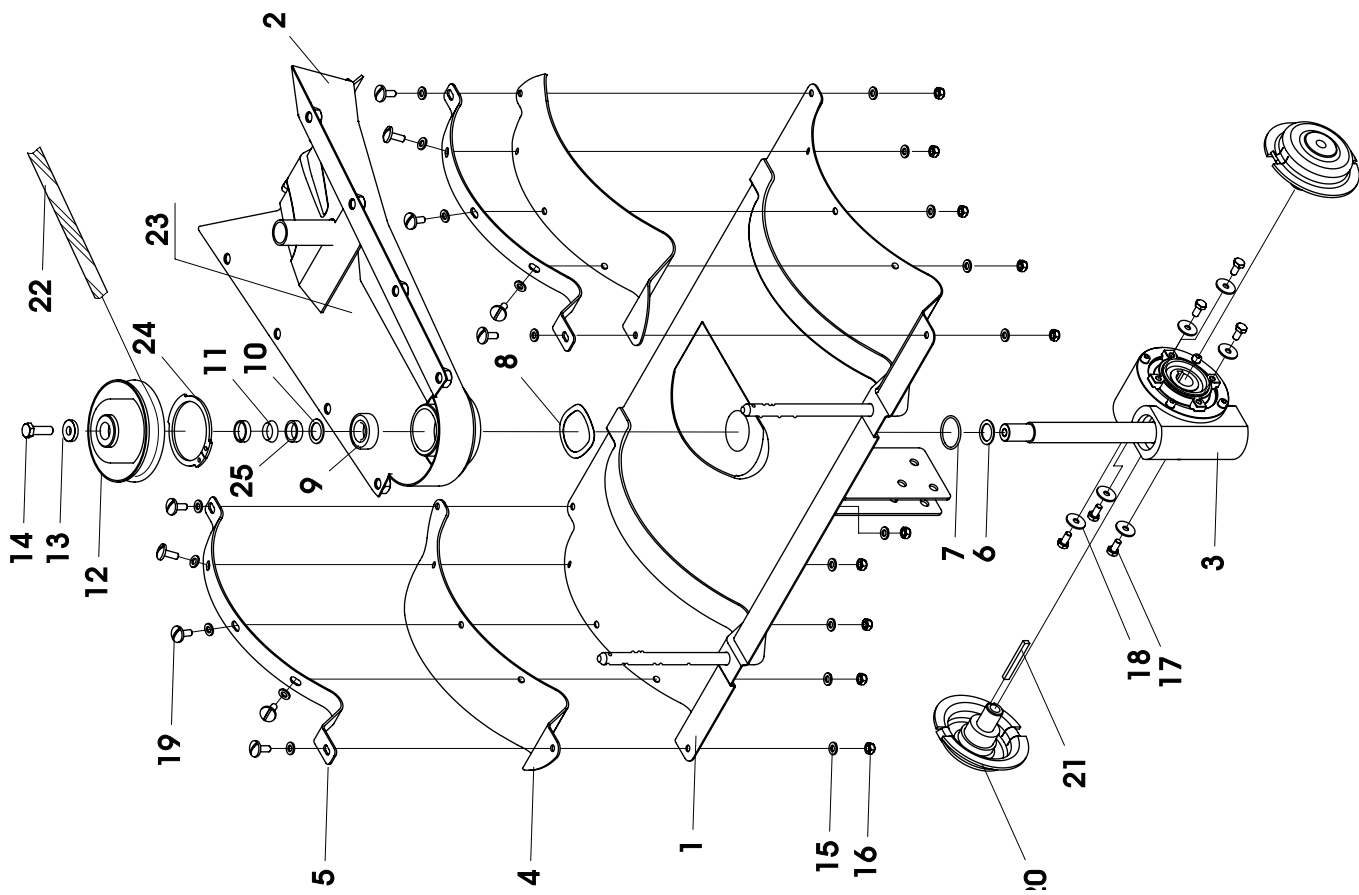

Pos.-Nr. Rep.	Bestellnummer Référéncé	Anzahl Qté.	Bezeichnung Quant.	Désignation	Description	Descrizione	Benevnelse	Bemerkung Remarque Remarks Osservazione Bemærkninger
Pos. Nr.	Article number Nr. codice	Quant. Q.tà		(F)	(GB)	(I)	(N)	
Bilde-Nr.	Bestillings-Nr	Antall	(D)					
1	DA-201-028-3000	1	Haube	Chapeau	Cover	Cofano	Deksel	
2	AD-390-146-3000	1	Seitenteil rechts	Paroi latérale,droite	Side cover, right	Fianchetto, dx destro (a)	Sidedeksel, høyre	
3	AD-390-145-3000	1	Seitenteil links	Paroi latérale, gauche	Side cover, left	Fianchetto, sx sinistro (a)	Sidedeksel, venstre	
(4)	AD-380-055TS	1	Radantr.-Getriebe	Boîte de vitesses	Gear drive	Trasmissione	Gear	
(5)	DA-180-256z	1	Lagerflansch	Palier	Bearing flange	Flangia cuscinetto	Lagerflens	M5x12
6	HO-020-029z	8	Sechskantschraube	Vis à six pans	Hexagon bolt	Vite esagonale	Sekskantskrue	10x5,3x1
7	HW-010-002z	8	Scheibe	Rondelle	Washer	Rondella	Skive	M5
8	HR-030-003z	8	Sicherungsmutter	Écrou de sûreté	Locknut	Dado autobloccante	Låsemutter	Rør
9	DN-240-001-3000	2	Wickelschutz	Protection antienroulement		Coilprotector	Protezione	I=39/16
(10)	AD-380-156e	1	Zwischenwelle	Arbre intermédiaire	Layshaft	Albero intermedio	Aksel	
(11)	AD-390-142z	1	Achse	Arbre	Axle	Asse	Aksel	
(12)	AD-380-155e	1	Kettenrad	Roue de chaîne	Sprocket	Ruota dentata	Kjedehjul	
(13)	HX-010-208	1	Spannstift	Goupille de serrage	Spring pin	Spina elastica	Spennstift	
14	HW-050-007z	6	Scheibe	Rondelle	Washer	Rondella	Skive	8,4x21x4
15	HU-060-005z	1	Federscheibe	Rondelle de ressort	Spring washer	Rondella elastica	Sprengskive	
16	DC-060-077z	1	Spanner	Tendeur	Tensioner	Tenditore	Strammer	
(17)	HD-040-012	1	Rollenkette	Chaîne à rouleaux	Roller chain	Catena a rullini	Kjede	
(18)	HD-040-011	1	Rollenkette	Chaîne à rouleaux	Roller chain	Catena a rullini	Kjede	
19	HO-020-082z	6	Sechskantschraube	Vis à six pans	Hexagon bolt	Vite esagonale	Sekskantskrue	M8x16
20	HR-010-005z	2	Sechskantmutter	Écrou à six pans	Hexagon nut	Dado esagonale	Sekskantmutter	M8
21	HW-050-007z	2	Scheibe	Rondelle	Washer	Rondella	Skive	8,4x21x4
22	HO-110-122z	1	Augenschraube	Vis	Bolt	Vite	Skru	
23	HW-030-010z	1	Scheibe	Rondelle	Washer	Rondella	Skive	11x34x4
24	HR-010-006z	1	Sechskantmutter	Écrou à six pans	Hexagon nut	Dado esagonale	Sekskantmutter	M10
25	HW-010-007z	8	Scheibe	Rondelle	Washer	Rondella	Skive	8,4x16x1,6
26	HO-020-082z	8	Sechskantschraube	Vis à six pans	Hexagon bolt	Vite esagonale	Sekskantskrue	M8x16
(27)	HJ-010-208	1	Distanzhülse	Douille	Spacer tube	Boccola	Hy/Is	
(28)	HJ-010-217	1	Distanzhülse	Douille	Spacer tube	Boccola	Hy/Is	



Pos.-Nr. Rep.	Bestellnummer Réfrence	Anzahl Qté.	Bezeichnung	Désignation	Description	Descrizione	Benevnelse	Bemerkung Remarque Remarks Osservazione Bemerkninger
Pos. Pos. Bilde-Nr.	Article number Nr. codice Bestillings-Nr	Quant. Q.tà Antall						
(1)	AD-390-144-9005	1	Getriebehalter	Support d'entraînement	Gear stud	Supporto trasmissione	Gearholder	
2	AD-380-157-3000	1	Unterteil	Pièce inférieure	Bottom part	Parte inferiore	Nedre del	
(3)	AD-340-056TS	1	Schneckengetriebe	Schneckengetriebe	Boîte de vis sans fin	Auger gear drive	Trasmisione chiocciola	Gear
(4)	HK-005-039	2	Verbreiterungen	Rallonge	Extension	Prolunga	Forlenger	
5	DA-180-319-9005	2	Leiste	Lardon	Ledge	Listello	List	
6	HW-080-101	1	Paßscheibe	Rondelle	Shaft spacer	Anello distanziale	Skive	
7	HK-002-009	1	O-Ring	Bague	Oring	Oring	Oring	
8	HT-050-041	1	Wellfederscheibe	Rondelle de ressort	Spring washer	Rondella elastica	Sprengskive	
(9)	HA-030-004	1	Kugellager	Roulement à billes	Ball bearing	Cuscinetto a sfere	Kulelager	
10	HW-080-105	1	Paßscheibe	Rondelle	Shaft spacer	Anello distanziale	Skive	
11	KC-001-082	1	Spannelemente	Pièce de serrage	Tensioning piece	Parte tenditore	Spennstykke	
12	AZ-001-413-9005	1	Keilriemenscheibe	Poulie	Vbelt pulley	Puleggia	Kileremskive	
13	HW-050-007z	1	Scheibe	Rondelle	Washer	Rondella	Skive 8,4x21x4	M8x20
14	HO-020-083z	1	Sechskantschraube	Vis à six pans	Hexagon bolt	Vite esagonale	Sekskantskrue	6,4x16x1
15	HW-010-004z	20	Scheibe	Rondelle	Washer	Rondella	Skive	M6
16	HR-030-004z	10	Sicherungsmutter	Écrou de sûreté	Locknut	Dado autobloccante	Låsemutter	
17	HW-030-005z	6	Scheibe	Rondelle	Washer	Rondella	Skive	6,6x22x2
18	HO-020-053z	6	Sechskantschraube	Vis à six pans	Hexagon bolt	Vite esagonale	Sekskantskrue	M6x12
19	HO-050-054z	10	Innensechskantschrauben	Vis Inbus	Allan screw	Vite brugola	Innesekskantskrue	M6x16
20	AD-340-146-9005	2	Mitnehmer	Entraîneur	Drive pin	Trascinatore	Medbringer	
21	KH-010-015	1	Paßfeder	Ressort	Parallel key	Linguetta	Kile	
(22)	HB-220-285	1	Spezial Keilriemen	Courroie	Vbelt	Cinghia	Kilerem	
23	KD-003-002	1	Aufkleber	Autocollant	Label	Autoadesivo	Dekal	
24	HU-010-040	1	Sicherungsring	Anneau d'arrêt	Retaining ring	Seget	Semering	A40
25	KC-001-081	1	Abstandshülse	Douille	Spacer tube	Boccola	Hylse	

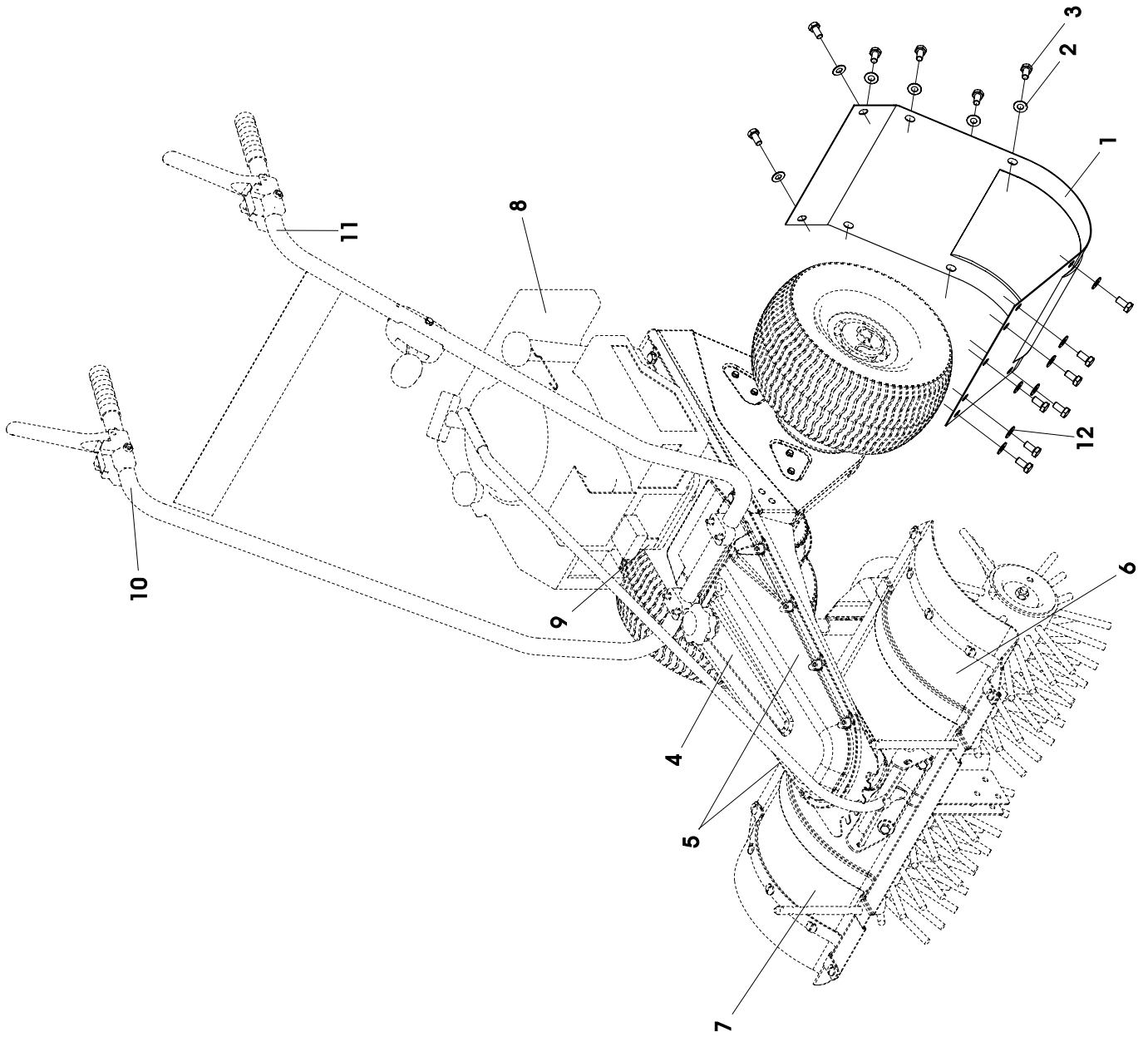

Pos.-Nr. Rep.	Bestellnummer Réfrence	Anzahl Qté.	Bezeichnung	Désignation	Description	Descrizione	Benevnelse	Bemerkung Remarque Remarks Osservazione Bemerkninger
Pos. Pos.	Article number Nr. codice	Quant. Q.tà		(F)	(GB)	(I)	(N)	
Bilde-Nr.	Bestillings-Nr	Antall						
1	DA-180-257-3000	1	Bodenblech	Fond en tôle	Bottom plate	Lamierino	Deksel	
2	HW-010-007z	10	Scheibe	Rondelle	Washer	Rondella	Skive	8,4x16x1,6
3	HO-020-082z	13	Sechskantschraube	Vis à six pans	Hexagon bolt	Vite esagonale	Sekskantskrue	M8x16
4	KD-003-110	1	Aufkleber	Autocollant	Label	Autoadesivo	Dekal	
5	KD-001-002	2	Aufkleber	Autocollant	Label	Autoadesivo	Dekal	
6	KD-003-092	1	Aufkleber	Autocollant	Label	Autoadesivo	Dekal	
7	KD-002-063	1	Aufkleber	Autocollant	Label	Autoadesivo	Dekal	
8	KD-003-050	1	Aufkleber	Autocollant	Label	Autoadesivo	Dekal	
9	KD-003-111	1	Aufkleber	Autocollant	Label	Autoadesivo	Dekal	
10	KD-003-036	1	Aufkleber	Autocollant	Label	Autoadesivo	Dekal	
11	KD-003-037	1	Aufkleber	Autocollant	Label	Autoadesivo	Dekal	
12	HW-060-007z	3	Scheibe	Rondelle	Washer	Rondella	Skive	8,4x25x2

fk18/Elektro. Schaltplan

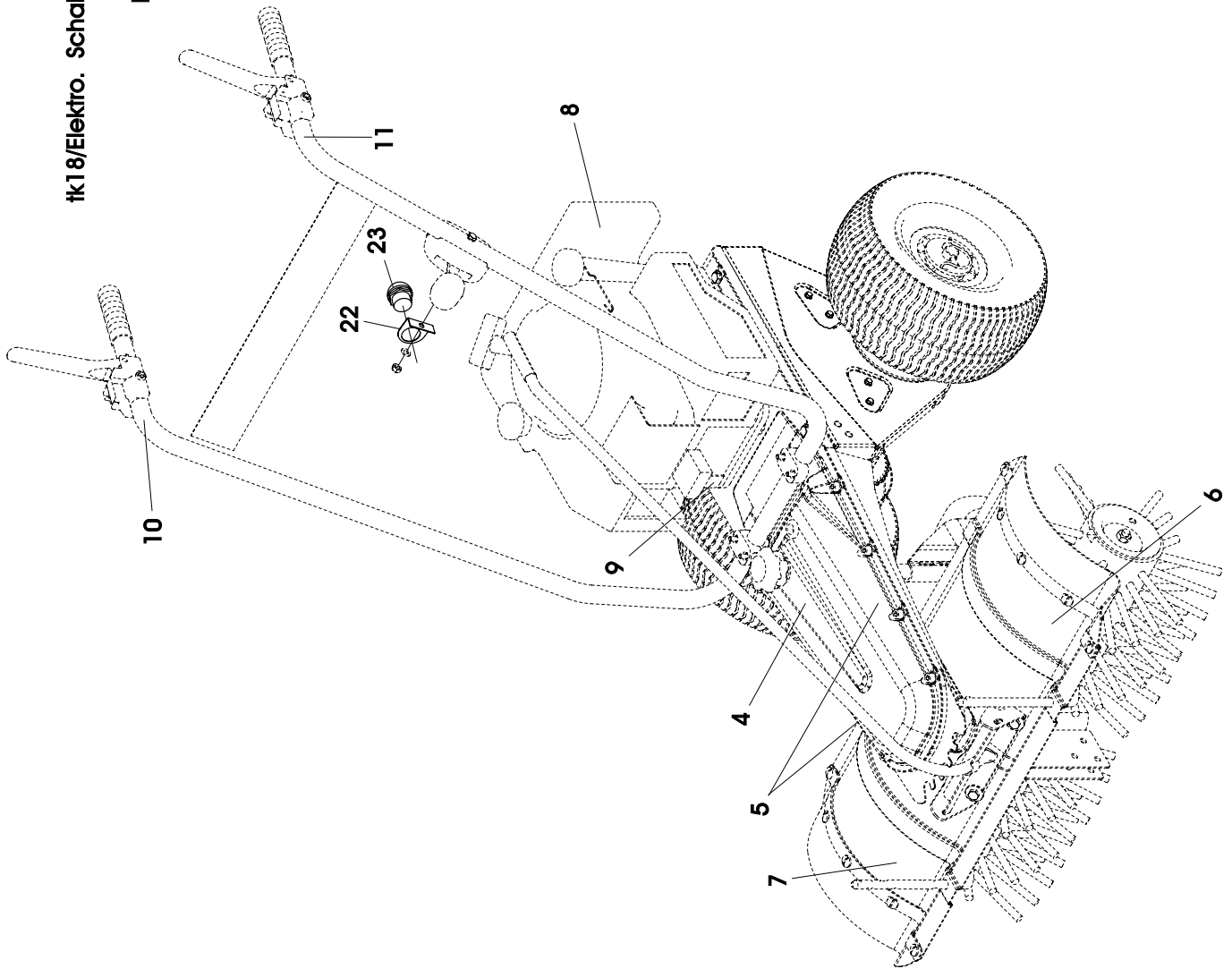

- F1-Hauptsicherung 40A
- F2-Steuersicherung 3A
- S1-Schlüsselschalter
- S2-Drucktaster
- K1-Anlassrelais
- M1-Anlasser
- G1-Ladespule
- L1-Ladesteckdose für Batterieladegerät

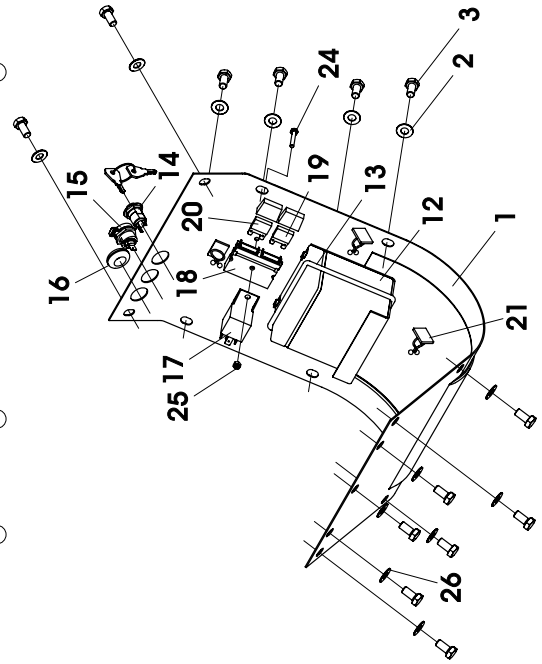
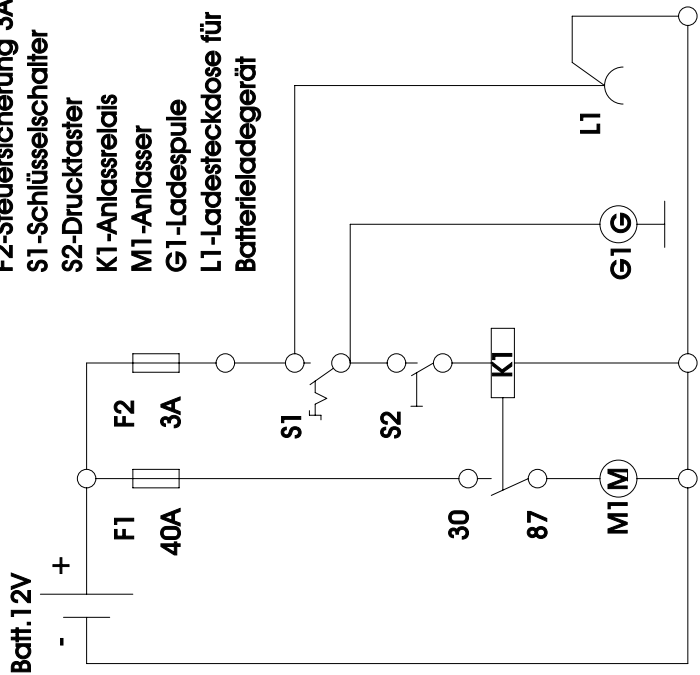

Pos.-Nr.	Bestellnummer	Anzahl	Bezeichnung	Désignation	Description	Descrizione	Benevnelse	Bemerkung
Rep.	Référence	Qté.						Remarks
Pos.	Article number	Quant.						Osservazione
Pos.	Nr. codice	Q.tà						Bemerkninger
Bilde-Nr.	Bestillings-Nr	Antall						
1	AD-390-143-3000	1	Bodenblech	Fond en tôle	Bottom plate	Lamierino	Deksel	
2	HW-010-007z	10	Scheibe	Rondelle	Washer	Rondella	Skive	8,4x16x1,6
3	HO-020-082z	13	Sechskantschraube	Vis à six pans	Hexagon bolt	Vite esagonale	Sekskantskrue	M8x16
4	KD-003-110	1	Aufkleber	Autocollant	Label	Autoadesivo	Dekal	
5	KD-001-002	2	Aufkleber	Autocollant	Label	Autoadesivo	Dekal	
6	KD-003-092	1	Aufkleber	Autocollant	Label	Autoadesivo	Dekal	
7	KD-002-063	1	Aufkleber	Autocollant	Label	Autoadesivo	Dekal	
8	KD-003-050	1	Aufkleber	Autocollant	Label	Autoadesivo	Dekal	
9	KD-003-011	1	Aufkleber	Autocollant	Label	Autoadesivo	Dekal	
10	KD-003-036	1	Aufkleber	Autocollant	Label	Autoadesivo	Dekal	
11	KD-003-037	1	Aufkleber	Autocollant	Label	Autoadesivo	Dekal	
(12)	KO-001-164	1	Batterie	Batterie (f)	Batterie	Batteria	Batterie	
13	HJ-010-192	2	Kabelbinder	Collier en plastique	Strap	Legaccio	Kabelfester	4,8x190
(14)	KO-001-166	1	Schlüsselschalter	Commutator de la clé	Keyswitch	Chiave avviamento		
(15)	KO-001-104	1	Steckdose	Prise de courant	Socket	Presa di corrente		
16	KO-001-103	1	Tülle	Guide	Rubber bush	Bussola di passaggio		
(17)	KO-001-128	1	Relais	Relais	Relay	Relè	Relay	50A
18	KO-001-127	1	Sicherungshalter	Support	Mounting plate	Supporto	Holder	
(19)	KO-001-144	1	Sicherung 3A	Fusible	Fuse	Fusibile	Sikring	
(20)	KO-001-143	1	Sicherung 40A	Fusible	Fuse	Fusibile	Sikring	
21	HJ-010-116	3	Driller	Fixation	Clip	Attacco	Klemme	
22	DA-140-544-9005	1	Winkel	Equerre	Angle bracket	Angolare	Vinkel	
(23)	KO-001-165	1	Drucktaster	Bouton	Puch button	Pulsante	Pushbutton	
24	HO-020-009z	1	Sechskantschraube	Vis à six pans	Hexagon bolt	Vite esagonale	Sekskantskrue	M4x25
25	HR-030-002z	1	Sicherungsmutter	Écrou de sûreté	Locknut	Dado autobloccante	Låsemutter	M4
26	HW-060-007z	3	Scheibe	Rondelle	Washer	Rondella	Skive	8,4x25x2

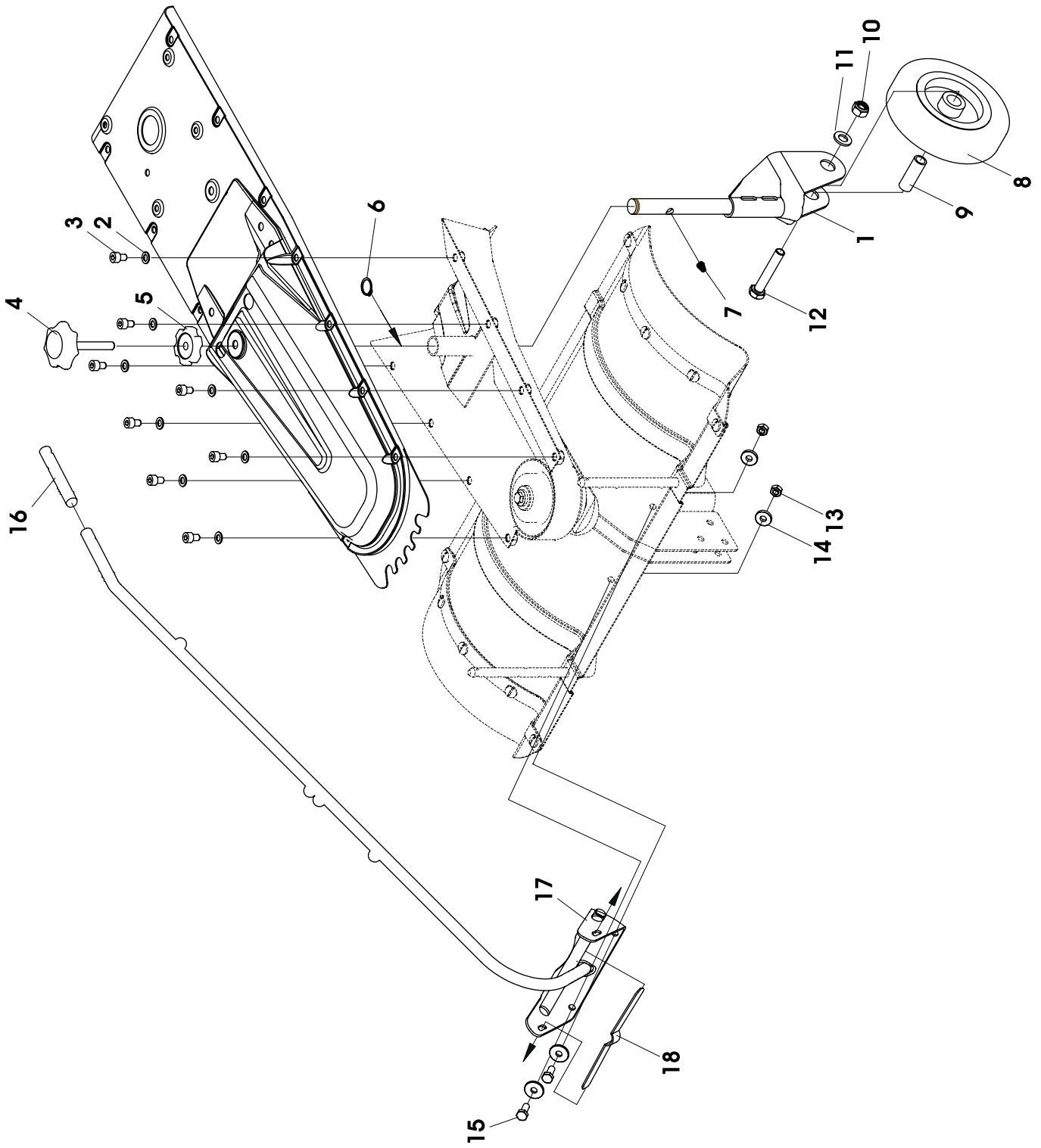

Pos.-Nr.	Bestellnummer	Anzahl	Bezeichnung	Désignation	Description	Descrizione	Benevnelse	Bemerkung
Rep.	Référence	Qté.						Remark
Pos.	Article number	Quant.						Remarks
Pos.	Nr. codice	Q.tà						Osservazione
Bilde-Nr.	Bestillings-Nr	Antall						Bemerkninger
1	AD-380-151z	1	Radträger	Support de roue	(wheel) carrier	Supporto ruota	Hjulholder	ab Serien-Nr. 3379415
1	AD-390-151z	1	Radträger	Support de roue	(wheel) carrier	Supporto ruota	Hjulholder	8,4x15x1,6
2	HW-020-007z	8	Scheibe	Rondelle	Washer	Rondella	Skive	M8x12
3	HO-040-081z	8	Innensechskantschraube	Vis Inbus	Allan screw	Vite brugola	Innesechskantskrue	M10x60
4	HJ-010-019	1	Sterngriff	Molette	Star grip	Pomello stella	Handtak	M10
5	HS-050-006z	1	Rändelmutter	Écrou moleté incorporé	Knurled nut	Ha godronato la noce	Knurled mutter	A20
6	HU-010-020	1	Sicherungsring	Anneau d'arrêt	Retaining ring	Sejer	Semering	
(7)	HI-020-016	1	Kegele Druckfeder	Ressort de pression	Compression spring	Molla di compressione	Fjær	
(8)	KC-001-008	1	Lauftrad	Roulette	Passive wheel	Ruotino	Hjul	
(9)	KC-001-009	1	Laufbuchse	Coussinet	Sleeve	Boccola	Foring	
10	HR-030-007z	1	Sicherungsmutter	Écrou à six pans	Hexagon nut	Dado esagonale	Sekskantmutter	M12
11	HW-010-011z	1	Scheibe	Rondelle	Washer	Rondella	Skive	10,5x20x2
12	HO-010-157z	1	Sechskantschraube	Vis à six pans	Hexagon bolt	Vite esagonale	Sekskantskrue	M12x70
13	HR-010-005z	2	Sechskantmutter	Écrou à six pans	Hexagon nut	Dado esagonale	Sekskantmutter	M8
14	HW-010-007z	4	Scheibe	Rondelle	Washer	Rondella	Skive	8,4x16x1,6
15	HO-020-083z	2	Sechskantschraube	Vis à six pans	Hexagon bolt	Vite esagonale	Sekskantskrue	M8x20
16	HJ-010-015	1	PVC- Handgriff	Poignée	PVCgrip	Manopola PVC	Handtak	
17	AD-390-147z	1	Schwenkhebel	Levier	Selecting rod	Leva orientamento	Hendel	
(18)	HI-030-011z	1	Blattfeder	Lame ressort	Blade spring	Molla a balestra	Bladefjær	

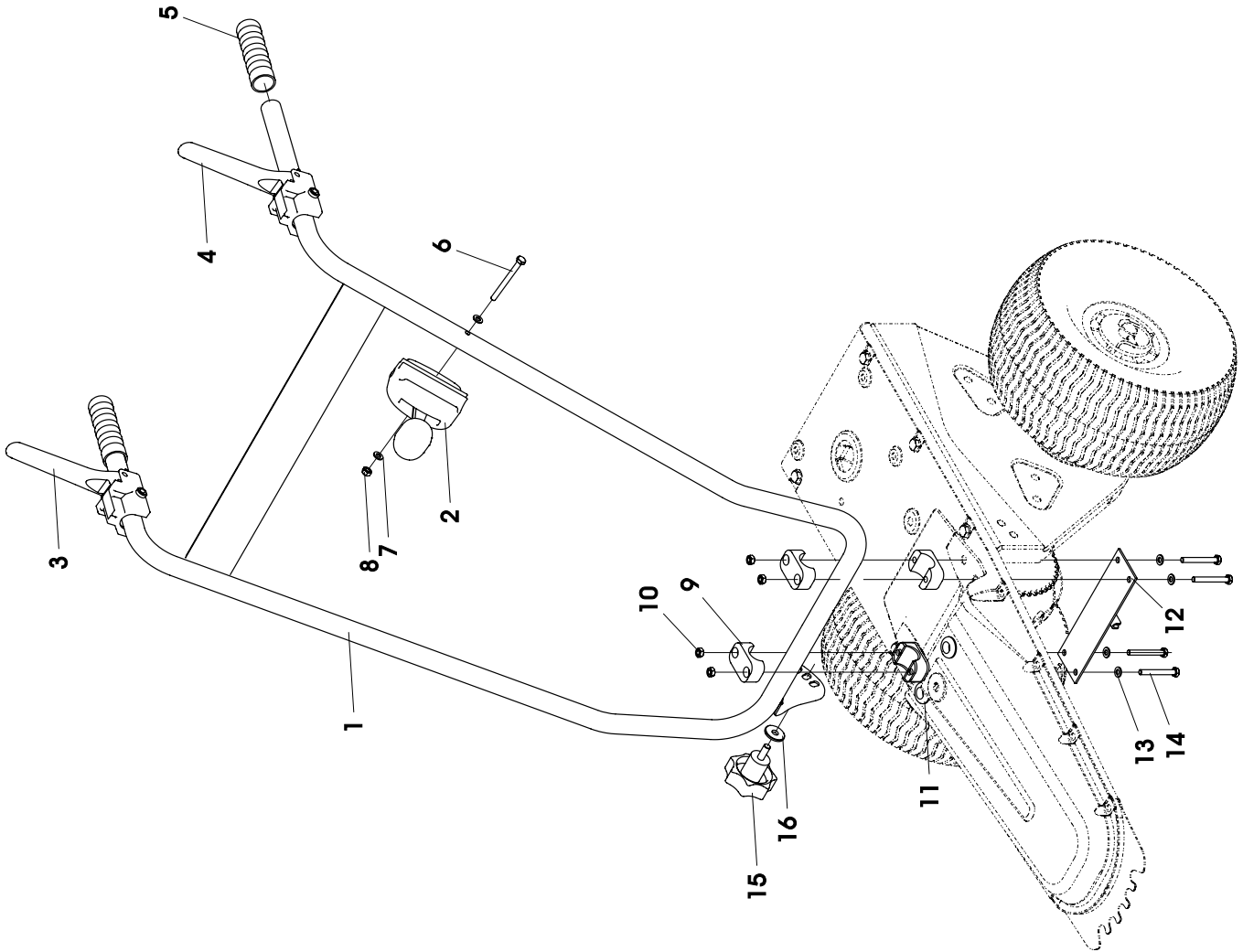

Pos.-Nr.	Bestellnummer	Anzahl	Bezeichnung	Désignation	Description	Descrizione	Benevnelse	Bemerkung
Rep.	Référence	Qté.						Remark
Pos.	Article number	Quant.						Remarks
Pos.	Nr. codice	Q.tà						Osservazione
Bilde-Nr.	Bestillings-Nr	Antall						Bemerkninger
1	AD-390-140p9010	1	Lenker	Mancheron	Handle bars	Manubrio	Styre	
(2)	AZ-006-109	1	Gashebel	Accélérateur	Throttle lever	Leva gas	Gasshendel	Honda
(2)	AZ-006-108	1	Gashebel	Accélérateur	Throttle lever	Leva gas	Gasshendel	B&S
(3)	AZ-007-080	1	Hebel Bürstenantrieb (Kehrbürstenantrieb)	Lever (Entraînement de la brosse) (Brush drive)	Lever	Leva (Trazione spazzole)	Hendel (Børstedrift)	
(4)	AZ-007-079	1	Hebel Fahrtrieb (Fahrtrieb)	Lever (Entraînement)	Lever (Drive)	Leva (Avanzamento)	Hendel (Frendrift)	
5	HJ-010-018	2	PVC- Handgriff	Poignée	Handle	Leva	Handtak	
6	HO-010-064z	1	Sechskantschraube	Vis à six pans	Hexagon bolt	Vite esagonale	Sekskantskrue	M6x65
7	HW-010-004z	2	Scheibe	Rondelle	Washer	Rondella	Skive	6,4x16x1
8	HR030-004z	1	Sicherungsmutter	Écrou à six pans	Hexagon nut	Dado esagonale	Sekskantmutter	M6
9	HJ-010-199	2	Rohrschelle	Collier	Pipe clamp	Morsetto del tubo	Schel	D=25
10	HR-010-004z	4	Sechskantmutter	Écrou à six pans	Hexagon nut	Dado esagonale	Sekskantmutter	M6
11	KO-001-103	2	Tülle	Guide	Rubber bush	Bussola di passaggio	Gjennomføring	
12	AD-380-154-9005	1	Stütze	Support	Bracket	Supporto	Støtte	
13	HW-010-004z	4	Scheibe	Rondelle	Washer	Rondella	Skive	6,4x16x1
14	HO-020-061z	4	Sechskantschraube	Vis à six pans	Hexagon bolt	Vite esagonale	Sekskantskrue	M6x50
15	HJ-010-063	1	Sterngriff	Poignée	Handle	Leva	Handtak	
16	HW-060-007z	1	Scheibe	Rondelle	Washer	Rondella	Skive	8,4x25x2