

Codice / Code / Code / Kode / Código
<b>9828093196 00</b>
Edizione / Edition / Edition / Ausgabe / Edición
<b>01/10/2017</b>

**CPA 7,5 - 10 - 15 (C55\*)  
CPA 20 (C67)**

CATALOGO RICAMBI  
SPARES PARTS LIST  
CATALOGUE PIÈCES DÉTACHÉES  
ERSATZTEILKATALOG  
CATÁLOGO DE PIEZAS DE RECAMBIO

*Con kit di manutenzione  
With service kit  
Avec kit a maintenance  
Mit Wartungsaufbausatz  
Con kit de mantenimiento*

**HP 7,5 - 10 - 15 - 20  
kW 5,5 - 7,5 - 11 - 15**

COMPRESSORI INDUSTRIALI  
INDUSTRIAL COMPRESSORS  
COMPRESSEURS INDUSTRIELS  
INDUSTRIELLE KOMPRESSOREN  
COMPRESOR INDUSTRIAL

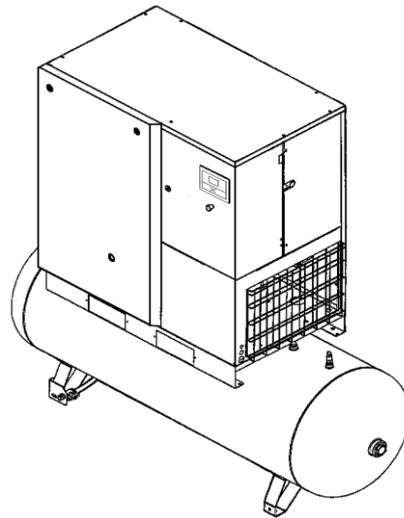
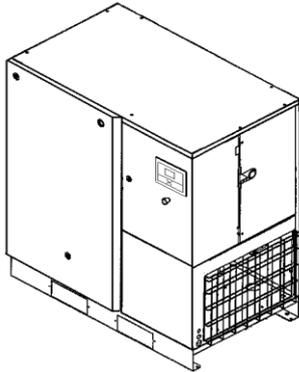

COMPRESSORI INDUSTRIALI - INDUSTRIAL COMPRESSORS - COMPRESSEURS INDUSTRIELS - INDUSTRIELLE KOMPRESSOREN - COMPRESOR INDUSTRIAL

Codice / Code / Code / Kode / Codigo	HP / kW	bar psi	Compressore Compressor Compresseur Kompressor Compresor	Serbatoio aria Air Receiver Réservoir Luftbehälter Deposito de Aire	Essiccatore Dryer Sécheur Trockner Secador
<b>CPA 7,5 (400/50Hz)</b>					
4152 0250 48	7,5/5,5	8	400/3/50Hz		
4152 0250 49	7,5/5,5	10	400/3/50Hz		
4152 0250 56	7,5/5,5	8	400/3/50Hz		230/1/50Hz
4152 0250 57	7,5/5,5	10	400/3/50Hz		230/1/50Hz
4152 0250 64	7,5/5,5	8	400/3/50Hz	270Lit.	
4152 0250 65	7,5/5,5	10	400/3/50Hz	270Lit.	
4152 0250 80	7,5/5,5	8	400/3/50Hz	270Lit.	230/1/50Hz
4152 0250 81	7,5/5,5	10	400/3/50Hz	270Lit.	230/1/50Hz
4152 0250 72	7,5/5,5	8	400/3/50Hz	500Lit.	
4152 0250 73	7,5/5,5	10	400/3/50Hz	500Lit.	
4152 0250 88	7,5/5,5	8	400/3/50Hz	500Lit.	230/1/50Hz
4152 0250 89	7,5/5,5	10	400/3/50Hz	500Lit.	230/1/50Hz
<b>CPA 10 (400/50Hz)</b>					
4152 0250 50	10/7,5	8	400/3/50Hz		
4152 0250 51	10/7,5	10	400/3/50Hz		
4152 0250 52	10/7,5	13	400/3/50Hz		
4152 0250 58	10/7,5	8	400/3/50Hz		230/1/50Hz
4152 0250 59	10/7,5	10	400/3/50Hz		230/1/50Hz
4152 0250 60	10/7,5	13	400/3/50Hz		230/1/50Hz
4152 0250 66	10/7,5	8	400/3/50Hz	270Lit.	
4152 0250 67	10/7,5	10	400/3/50Hz	270Lit.	
4152 0250 68	10/7,5	13	400/3/50Hz	270Lit.	
4152 0250 82	10/7,5	8	400/3/50Hz	270Lit.	230/1/50Hz
4152 0250 83	10/7,5	10	400/3/50Hz	270Lit.	230/1/50Hz
4152 0250 84	10/7,5	13	400/3/50Hz	270Lit.	230/1/50Hz
4152 0250 74	10/7,5	8	400/3/50Hz	500Lit.	
4152 0250 75	10/7,5	10	400/3/50Hz	500Lit.	
4152 0250 76	10/7,5	13	400/3/50Hz	500Lit.	
4152 0250 90	10/7,5	8	400/3/50Hz	500Lit.	230/1/50Hz
4152 0250 91	10/7,5	10	400/3/50Hz	500Lit.	230/1/50Hz
4152 0250 92	10/7,5	13	400/3/50Hz	500Lit.	230/1/50Hz
<b>CPA 15 (400/50Hz)</b>					
4152 0250 53	15/11	8	400/3/50Hz		
4152 0250 54	15/11	10	400/3/50Hz		
4152 0250 55	15/11	13	400/3/50Hz		
4152 0250 61	15/11	8	400/3/50Hz		230/1/50Hz
4152 0250 62	15/11	10	400/3/50Hz		230/1/50Hz
4152 0250 63	15/11	13	400/3/50Hz		230/1/50Hz
4152 0250 69	15/11	8	400/3/50Hz	270Lit.	
4152 0250 70	15/11	10	400/3/50Hz	270Lit.	
4152 0250 71	15/11	13	400/3/50Hz	270Lit.	
4152 0250 85	15/11	8	400/3/50Hz	270Lit.	230/1/50Hz
4152 0250 86	15/11	10	400/3/50Hz	270Lit.	230/1/50Hz
4152 0250 87	15/11	13	400/3/50Hz	270Lit.	230/1/50Hz
4152 0250 77	15/11	8	400/3/50Hz	500Lit.	
4152 0250 78	15/11	10	400/3/50Hz	500Lit.	
4152 0250 79	15/11	13	400/3/50Hz	500Lit.	
4152 0250 93	15/11	8	400/3/50Hz	500Lit.	230/1/50Hz
4152 0250 94	15/11	10	400/3/50Hz	500Lit.	230/1/50Hz
4152 0250 95	15/11	13	400/3/50Hz	500Lit.	230/1/50Hz

Codice / Code / Code / Kode / Codigo	HP / kW	bar psi	Compressore Compressor Compresseur Kompressor Compresor	Serbatoio aria Air Receiver Réservoir Luftbehälter Deposito de Aire	Essiccatore Dryer Sécheur Trockner Secador
<b>CPA 20 (400/50Hz)</b>					
4152 0252 74	20/15	8	400/3/50Hz		
4152 0252 75	20/15	10	400/3/50Hz		
4152 0252 76	20/15	13	400/3/50Hz		
4152 0252 77	20/15	8	400/3/50Hz		230/1/50Hz
4152 0252 78	20/15	10	400/3/50Hz		230/1/50Hz
4152 0252 79	20/15	13	400/3/50Hz		230/1/50Hz
4152 0252 80	20/15	8	400/3/50Hz	270Lit.	
4152 0252 81	20/15	10	400/3/50Hz	270Lit.	
4152 0252 82	20/15	13	400/3/50Hz	270Lit.	
4152 0252 86	20/15	8	400/3/50Hz	270Lit.	230/1/50Hz
4152 0252 87	20/15	10	400/3/50Hz	270Lit.	230/1/50Hz
4152 0252 88	20/15	13	400/3/50Hz	270Lit.	230/1/50Hz
4152 0252 83	20/15	8	400/3/50Hz	500Lit.	
4152 0252 84	20/15	10	400/3/50Hz	500Lit.	
4152 0252 85	20/15	13	400/3/50Hz	500Lit.	
4152 0252 89	20/15	8	400/3/50Hz	500Lit.	230/1/50Hz
4152 0252 90	20/15	10	400/3/50Hz	500Lit.	230/1/50Hz
4152 0252 91	20/15	13	400/3/50Hz	500Lit.	230/1/50Hz



COMPRESSORI INDUSTRIALI - INDUSTRIAL COMPRESSORS - COMPRESSEURS INDUSTRIELS -  
INDUSTRIELLE KOMPRESSOREN - COMPRESOR INDUSTRIAL

Codice / Code / Code / Kode / Codigo	HP / kW	bar psi	Compressore Compressor Compresseur Kompressor Compresor	Serbatoio aria Air Receiver Réservoir Luftbehälter Deposito de Aire	Essiccatore Dryer Sécheur Trockner Secador
<b>CPA 7,5 (400/50Hz) - AS 1210</b>					
4152 0251 12	7,5/5,5	8	400/3/50Hz	500Lit.	
4152 0251 13	7,5/5,5	10	400/3/50Hz	500Lit.	
4152 0251 20	7,5/5,5	8	400/3/50Hz	500Lit.	230/1/50Hz
4152 0251 21	7,5/5,5	10	400/3/50Hz	500Lit.	230/1/50Hz
<b>CPA 10 (400/50Hz) - AS 1210</b>					
4152 0251 14	10/7,5	8	400/3/50Hz	500Lit.	
4152 0251 15	10/7,5	10	400/3/50Hz	500Lit.	
4152 0251 16	10/7,5	13	400/3/50Hz	500Lit.	
4152 0251 22	10/7,5	8	400/3/50Hz	500Lit.	230/1/50Hz
4152 0251 23	10/7,5	10	400/3/50Hz	500Lit.	230/1/50Hz
4152 0251 24	10/7,5	13	400/3/50Hz	500Lit.	230/1/50Hz
<b>CPA 15 (400/50Hz) - AS 1210</b>					
4152 0251 17	15/11	8	400/3/50Hz	500Lit.	
4152 0251 18	15/11	10	400/3/50Hz	500Lit.	
4152 0251 19	15/11	13	400/3/50Hz	500Lit.	
4152 0251 25	15/11	8	400/3/50Hz	500Lit.	230/1/50Hz
4152 0251 26	15/11	10	400/3/50Hz	500Lit.	230/1/50Hz
4152 0251 27	15/11	13	400/3/50Hz	500Lit.	230/1/50Hz

Codice / Code / Code / Kode / Codigo	HP / kW	bar psi	Compressore Compressor Compresseur Kompressor Compresor	Serbatoio aria Air Receiver Réservoir Luftbehälter Deposito de Aire	Essiccatore Dryer Sécheur Trockner Secador
<b>CPA 20 (400/50Hz) - AS 1210</b>					
4152 0252 98	20/15	8	400/3/50Hz	500Lit.	
4152 0252 99	20/15	10	400/3/50Hz	500Lit.	
4152 0253 00	20/15	13	400/3/50Hz	500Lit.	
4152 0253 01	20/15	8	400/3/50Hz	500Lit.	230/1/50Hz
4152 0253 02	20/15	10	400/3/50Hz	500Lit.	230/1/50Hz
4152 0253 03	20/15	13	400/3/50Hz	500Lit.	230/1/50Hz

COMPRESSORI INDUSTRIALI - INDUSTRIAL COMPRESSORS - COMPRESSEURS INDUSTRIELS -  
 INDUSTRIELLE KOMPRESSOREN - COMPRESOR INDUSTRIAL

Codice / Code / Code / Kode / Codigo	HP / kW	bar psi	Compressore Compressor Compresseur Kompressor Compresor	Serbatoio aria Air Receiver Réservoir Luftbehälter Deposito de Aire	Essiccatore Dryer Sécheur Trockner Secador
<b>CPA 7,5 (400/50Hz) - ASME-CNR</b>					
4152 0251 44	7,5/5,5	8	400/3/50Hz	120 Gall.	
4152 0251 45	7,5/5,5	10	400/3/50Hz	120 Gall.	
4152 0251 52	7,5/5,5	8	400/3/50Hz	120 Gall.	230/1/50Hz
4152 0251 53	7,5/5,5	10	400/3/50Hz	120 Gall.	230/1/50Hz
<b>CPA 10 (400/50Hz) - ASME-CNR</b>					
4152 0251 46	10/7,5	8	400/3/50Hz	120 Gall.	
4152 0251 47	10/7,5	10	400/3/50Hz	120 Gall.	
4152 0251 48	10/7,5	13	400/3/50Hz	120 Gall.	
4152 0251 54	10/7,5	8	400/3/50Hz	120 Gall.	230/1/50Hz
4152 0251 55	10/7,5	10	400/3/50Hz	120 Gall.	230/1/50Hz
4152 0251 56	10/7,5	13	400/3/50Hz	120 Gall.	230/1/50Hz
<b>CPA 15 (400/50Hz) - ASME-CNR</b>					
4152 0251 49	15/11	8	400/3/50Hz	120 Gall.	
4152 0251 50	15/11	10	400/3/50Hz	120 Gall.	
4152 0251 51	15/11	13	400/3/50Hz	120 Gall.	
4152 0251 57	15/11	8	400/3/50Hz	120 Gall.	230/1/50Hz
4152 0251 58	15/11	10	400/3/50Hz	120 Gall.	230/1/50Hz
4152 0251 59	15/11	13	400/3/50Hz	120 Gall.	230/1/50Hz

Codice / Code / Code / Kode / Codigo	HP / kW	bar psi	Compressore Compressor Compresseur Kompressor Compresor	Serbatoio aria Air Receiver Réservoir Luftbehälter Deposito de Aire	Essiccatore Dryer Sécheur Trockner Secador
<b>CPA 20 (400/50Hz) - ASME-CNR</b>					
4152 0253 10	20/15	8	400/3/50Hz	120 Gall.	
4152 0253 11	20/15	10	400/3/50Hz	120 Gall.	
4152 0253 12	20/15	13	400/3/50Hz	120 Gall.	
4152 0253 13	20/15	8	400/3/50Hz	120 Gall.	230/1/50Hz
4152 0253 14	20/15	10	400/3/50Hz	120 Gall.	230/1/50Hz
4152 0253 15	20/15	13	400/3/50Hz	120 Gall.	230/1/50Hz





N° TAV. DWG. NR. N° TABLE Nr. GRUPPENSATZ N. TAB.	<b>INDICE - INDEX - TABLE DES MATIERES - INHALTSVERZEICHNIS - INDICE</b>				
	<b>DESCRIZIONE</b>	<b>DESCRIPTION</b>	<b>DÉSIGNATION</b>	<b>BESCHREIBUNG</b>	<b>DESIGNACIÓN</b>
<b>1</b>	CARENATURA - PANNELLI FONO ASSORBENTI (270 Lit.)	CASING - SOUND DAMPING PANELS (270 Lit.)	CARENAGE - PANNEAUX INSONORISANTS (270 Lit.)	STANDER FÜR DIE VERKLEIDUNG AKUSTISCHE PLATTEN (270 Lit.)	CARENADO - PANELES FONOABSORBENTES (270 Lit.)
<b>2</b>	CARENATURA - PANNELLI FONO ASSORBENTI (500 Lit.)	CASING - SOUND DAMPING PANELS (500 Lit.)	CARENAGE - PANNEAUX INSONORISANTS (500 Lit.)	STANDER FÜR DIE VERKLEIDUNG AKUSTISCHE PLATTEN (500 Lit.)	CARENADO - PANELES FONOABSORBENTES (500 Lit.)
<b>3</b>	CARENATURA - PANNELLI FONO ASSORBENTI (SENZA SERBATOIO)	CASING - SOUND DAMPING PANELS (WITHOUT RECEIVER)	CARENAGE - PANNEAUX INSONORISANTS (SANS RÉSERVOIR)	STANDER FÜR DIE VERKLEIDUNG AKUSTISCHE PLATTEN (OHNE BEHÄLTER)	CARENADO - PANELES FONOABSORBENTES (SIN DEPÓSITO)
<b>4</b>	FILTRO ASPIRAZIONE REGOLATORE DI PORTATA HP 7,5-10-15-20 / kW 5,5-7,5-11-15	FLOW REGULATOR INTAKE FILTER HP 7,5-10-15-20 / kW 5,5-7,5-11-15	FILTRE D'ASPIRATION REGULATEUR DE DEBIT HP 7,5-10-15-20 / kW 5,5-7,5-11-15	SAUGFILTER MENGENREGLER HP 7,5-10-15-20 / kW 5,5-7,5-11-15	FILTRO DE ASPIRACIÓN REGULADOR DE CAUDAL HP 7,5-10-15-20 / kW 5,5-7,5-11-15
<b>5</b>	SERBATOIO - SEPARATORE ARIA/OLIO	AIR/OIL TANK - SEPARATOR	RÉSERVOIR - SEPARATEUR AIR/HUILE	LUFT/ÖL - BEHÄLTER - ABSCHIEDER	DEPÓSITO DE ACEITE - SEPARADOR AIRE/ACEITE
<b>6</b>	RAFFREDDATORE ARIA/OLIO HP 7,5 - 10 kW 5,5 - 7,5	AIR/OIL COOLER HP 7,5 - 10 kW 5,5 - 7,5	REFROIDISSEUR AIR/HUILE HP 7,5 - 10 kW 5,5 - 7,5	LUFT/ÖL KÜHLER HP 7,5 - 10 kW 5,5 - 7,5	REFRIGERADOR AIRE/ACEITE HP 7,5 - 10 kW 5,5 - 7,5
<b>7</b>	RAFFREDDATORE ARIA/OLIO HP 15 - 20 kW 11 - 15	AIR/OIL COOLER HP 15 - 20 kW 11 - 15	REFROIDISSEUR AIR/HUILE HP 15 - 20 kW 11 - 15	LUFT/ÖL KÜHLER HP 15 - 20 kW 11 - 15	REFRIGERADOR AIRE/ACEITE HP 15 - 20 kW 11 - 15
<b>8</b>	RAFFREDDATORE ARIA/OLIO HP 7,5 - 10 - 15 - 20 kW 5,5 - 7,5 - 11 - 15	AIR/OIL COOLER HP 7,5 - 10 - 15 - 20 kW 5,5 - 7,5 - 11 - 15	REFROIDISSEUR AIR/HUILE HP 7,5 - 10 - 15 - 20 kW 5,5 - 7,5 - 11 - 15	LUFT/ÖL KÜHLER HP 7,5 - 10 - 15 - 20 kW 5,5 - 7,5 - 11 - 15	REFRIGERADOR AIRE/ACEITE HP 7,5 - 10 - 15 - 20 kW 5,5 - 7,5 - 11 - 15
<b>9</b>	STAFFA PORTA MOTORE ELETTRICO COMPRESSORE A VITE - TRASMISSIONE - HP 7,5 - 10 - 15 / kW 5,5 - 7,5 - 11	SCREW COMPRESSOR AND ELECTRIC MOTOR METAL SUPPORT - TRANSMISSION - HP 7,5 - 10 - 15 / kW 5,5 - 7,5 - 11	ETRIER SUPPORTE MOTEUR ELECTRIQUE COMPRESSEUR A VIS - TRANSMISSION - HP 7,5 - 10 - 15 / kW 5,5 - 7,5 - 11	SCHRAUBENKOMPRESSOR-UND ELETROMOTORSTÜZE RIEMENTRIEB - HP 7,5 - 10 - 15 / kW 5,5 - 7,5 - 11	ESTRIBO SOPORTE MOTOR ELÉCTRICO COMPRESOR DE TORNILLO - TRANSMISIÓN POR CORREA - HP 7,5 - 10 - 15 / kW 5,5 - 7,5 - 11
<b>10</b>	STAFFA PORTA MOTORE ELETTRICO COMPRESSORE A VITE - TRASMISSIONE - HP 20 / kW 15	SCREW COMPRESSOR AND ELECTRIC MOTOR METAL SUPPORT - TRANSMISSION - HP 20 / kW 15	ETRIER SUPPORTE MOTEUR ELECTRIQUE COMPRESSEUR A VIS - TRANSMISSION - HP 20 / kW 15	SCHRAUBENKOMPRESSOR-UND ELETROMOTORSTÜZE RIEMENTRIEB - HP 20 / kW 15	ESTRIBO SOPORTE MOTOR ELÉCTRICO COMPRESOR DE TORNILLO - TRANSMISIÓN POR CORREA - HP 20 / kW 15
<b>11</b>	PANNELLO COMANDI E QUADRO ELETTRICO	ELECTRIC BOARD CONTROL PANEL	PANNEAU DE COMMANDES TABLEAU ELECTRIQUE	ELEKTRISCHE SCHALTТАFEL	PANEL DE MANDOS Y TABLERO ELÉCTRICO
<b>12</b>	ESSICCATORE D'ARIA	AIR DRYER	SECHEUR D'AIR	LUFTTROCKNER	SECADOR DE AIRE
<b>13</b>	TARGHETTE	LABELS	PLAQUE	SCHILD	PLACA
<b>14</b>	KIT DI MANUTENZIONE	SERVICE KITS	KITS DE MAINTENANCE	AUFBAUSATZ DES WARTUNG	KIT DE MANTENIMIENTO

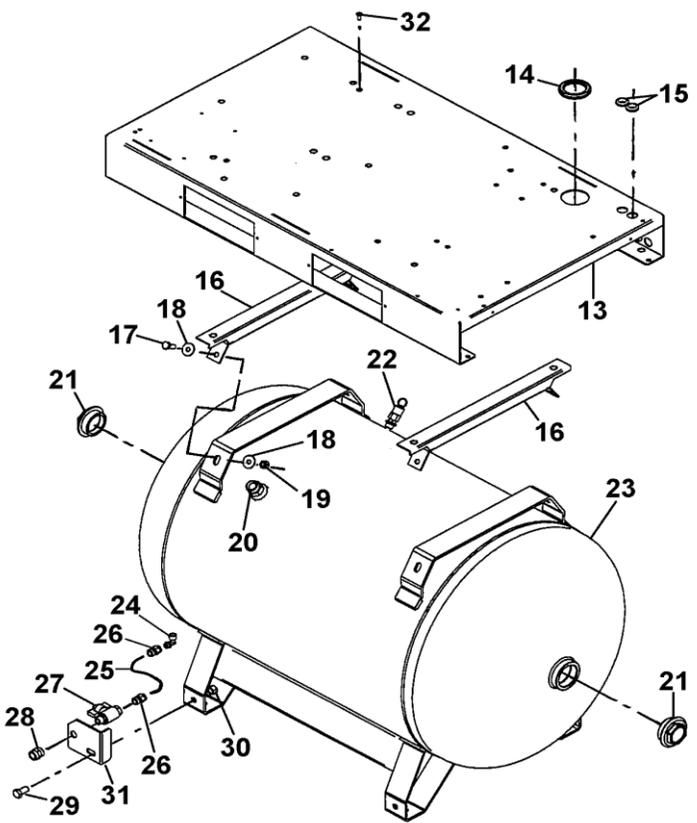
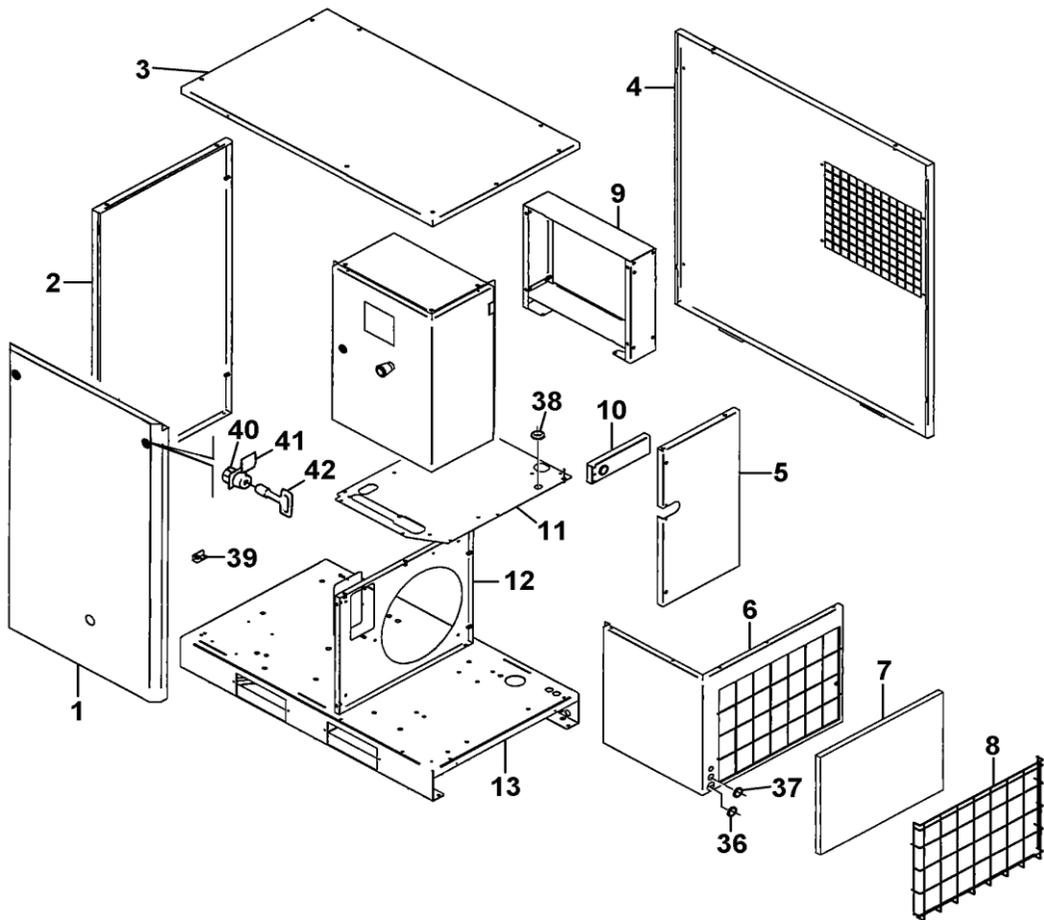

270 LIT.





TAB. 1			Q.tà - Qty - Qté - Anz. - Cant. (270 Lit.)																Carenatura - Pannelli fono assorbenti Casing - Sound-damping panels Carenage-panneaux insonorisants Stander für die Verkleidung akustische Platten Carenado - Paneles fonoabsorbentes											
			HP 20 / kW 15 (400/50 Hz)				HP 20 / kW 15 (230/50 Hz)				HP 20 / kW 15 (230/60 Hz)				HP 20 / kW 15 (380-440/60 Hz)				DESCRIZIONE - DESCRIPTION - DESIGNATION - BESCHREIBUNG - DESIGNACION											
Rif. N. Ref. No Nr. Rêf. Bild Nr. Rif. N.	N. ordinaz. Part. num. Nr. Pièce Teil Nr. Codigo	Note-Note- Anm.-Nota	4152 0252 80	4152 0252 81	4152 0252 82	4152 0252 86	4152 0252 87	4152 0252 88		4152 0252 62	4152 0252 63	4152 0252 64	4152 0252 68	4152 0252 69	4152 0252 70		4152 0253 22	4152 0253 23					4152 0253 24	4152 0253 28	4152 0253 29	4152 0253 30		4152 0253 40	4152 0253 41	4152 0253 42
1	2202 9461 88		1	1	1	1	1	1		1	1	1	1	1	1		1	1	1	1	1	1		1	1	1	1	1	1	PANEL
2	2203 0583 17		1	1	1	1	1	1		1	1	1	1	1	1		1	1	1	1	1	1		1	1	1	1	1	1	PANEL
3	2202 9530 16		1	1	1	1	1	1		1	1	1	1	1	1		1	1	1	1	1	1		1	1	1	1	1	1	COVER
4	2203 0582 17		1	1	1	1	1	1		1	1	1	1	1	1		1	1	1	1	1	1		1	1	1	1	1	1	PANEL
5	2203 0584 16		1	1	1	1	1	1		1	1	1	1	1	1		1	1	1	1	1	1		1	1	1	1	1	1	PANEL
6	2202 9533 16		1	1	1	1	1	1		1	1	1	1	1	1		1	1	1	1	1	1		1	1	1	1	1	1	PANEL
7	2202 2512 10		1	1	1	1	1	1		1	1	1	1	1	1		1	1	1	1	1	1		1	1	1	1	1	1	FILTER ELEMENT
8	2202 2512 09		1	1	1	1	1	1		1	1	1	1	1	1		1	1	1	1	1	1		1	1	1	1	1	1	GRATING
9	2202 9473 00		1	1	1	1	1	1		1	1	1	1	1	1		1	1	1	1	1	1		1	1	1	1	1	1	STIRRUP SUPPORT COOLER
10	2202 9472 16		1	1	1	1	1	1		1	1	1	1	1	1		1	1	1	1	1	1		1	1	1	1	1	1	STIRRUP SUPPORT
11	2204 1021 16		1	1	1	1	1	1		1	1	1	1	1	1		1	1	1	1	1	1		1	1	1	1	1	1	BAFFLE UNDER CUBICLE
12	2202 9470 24		1	1	1	1	1	1		1	1	1	1	1	1															BAFFLE CONVEYOR
12	2202 9470 04																1	1	1	1	1	1		1	1	1	1	1	1	BAFFLE CONVEYOR
13	2202 9460 16		1	1	1	1	1	1		1	1	1	1	1	1		1	1	1	1	1	1		1	1	1	1	1	1	FRAME
14	1088 0803 08		1	1	1	1	1	1		1	1	1	1	1	1		1	1	1	1	1	1		1	1	1	1	1	1	GROMMET
15	0989 4220 08				2	2	2					2	2	2					2	2	2					2	2	2		GROMMET
16	2202 9539 00		2	2	2	2	2			2	2	2	2	2	2		2	2	2	2	2	2		2	2	2	2	2	2	STIRRUP
17	0147 1362 03		4	4	4	4	4	4		4	4	4	4	4	4		4	4	4	4	4	4		4	4	4	4	4	4	SCREW
18	0300 0274 17		8	8	8	8	8	8		8	8	8	8	8	8		8	8	8	8	8	8		8	8	8	8	8	8	WASHER
19	0266 2111 00		4	4	4	4	4	4		4	4	4	4	4	4		4	4	4	4	4	4		4	4	4	4	4	4	NUT
20	0571 0035 52		1	1	1	1	1	1		1	1	1	1	1	1		1	1	1	1	1	1		1	1	1	1	1	1	NIPPLE
21	2200 7509 11		2	2	2	2	2			2	2	2	2	2	2		2	2	2	2	2	2		2	2	2	2	2	2	PLUG
22	2202 8891 03		1	1	1	1				1	1		1	1			1	1		1	1			1	1		1	1		SAFETY VALVE
22	2202 8891 02			1							1							1							1				1	SAFETY VALVE
23	2202 9783 47		1	1	1	1	1	1		1	1	1	1	1	1		1	1	1	1	1	1		1	1	1	1	1	1	AIR RECEIVER
24	0605 9500 42		1	1	1	1	1	1		1	1	1	1	1	1		1	1	1	1	1	1		1	1	1	1	1	1	ELBOW COUPLING
25	0070 6002 64		X	X	X	X	X	X		X	X	X	X	X	X		X	X	X	X	X	X		X	X	X	X	X	X	HOSE (IN METERS)
26	0583 8100 89		2	2	2	2	2	2		2	2	2	2	2	2		2	2	2	2	2	2		2	2	2	2	2	2	COUPLING
27	0852 0010 09		1	1	1	1	1	1		1	1	1	1	1	1		1	1	1	1	1	1		1	1	1	1	1	1	BALL VALVE
28	0607 1150 08		1	1	1	1	1	1		1	1	1	1	1	1		1	1	1	1	1	1		1	1	1	1	1	1	SLEEVE
29	0147 1400 03		1	1	1	1	1	1		1	1	1	1	1	1		1	1	1	1	1	1		1	1	1	1	1	1	SCREW
30	0266 2112 00		1	1	1	1	1	1		1	1	1	1	1	1		1	1	1	1	1	1		1	1	1	1	1	1	NUT
31	2202 9663 00		1	1	1	1	1	1		1	1	1	1	1	1		1	1	1	1	1	1		1	1	1	1	1	1	STIRRUP
32	0216 1957 73		4	4	4	4	4	4		4	4	4	4	4	4		4	4	4	4	4	4		4	4	4	4	4	4	SCREW
36	0989 4220 47		1	1	1	1	1	1		1	1	1	1	1	1		1	1	1	1	1	1		1	1	1	1	1	1	GROMMET
37	0989 4220 08				1	1	1	1				1	1	1	1				1	1	1	1				1	1	1	1	GROMMET
38	1088 0803 07		1	1	1	1	1	1		1	1	1	1	1	1		1	1	1	1	1	1		1	1	1	1	1	1	GROMMET
39	2202 9476 00		1	1	1	1	1	1		1	1	1	1	1	1		1	1	1	1	1	1		1	1	1	1	1	1	STIRRUP FOR LEFT PANEL
40	2200 5402 76		2	2	2	2	2	2		2	2	2	2	2	2		2	2	2	2	2	2		2	2	2	2	2	2	DOOR LOCK
41	2202 2512 59		2	2	2	2	2	2		2	2	2	2	2	2		2	2	2	2	2	2		2	2	2	2	2	2	DRAW LATCH
42	2200 5402 64		1	1	1	1	1	1		1	1	1	1	1	1		1	1	1	1	1	1		1	1	1	1	1	1	KEY

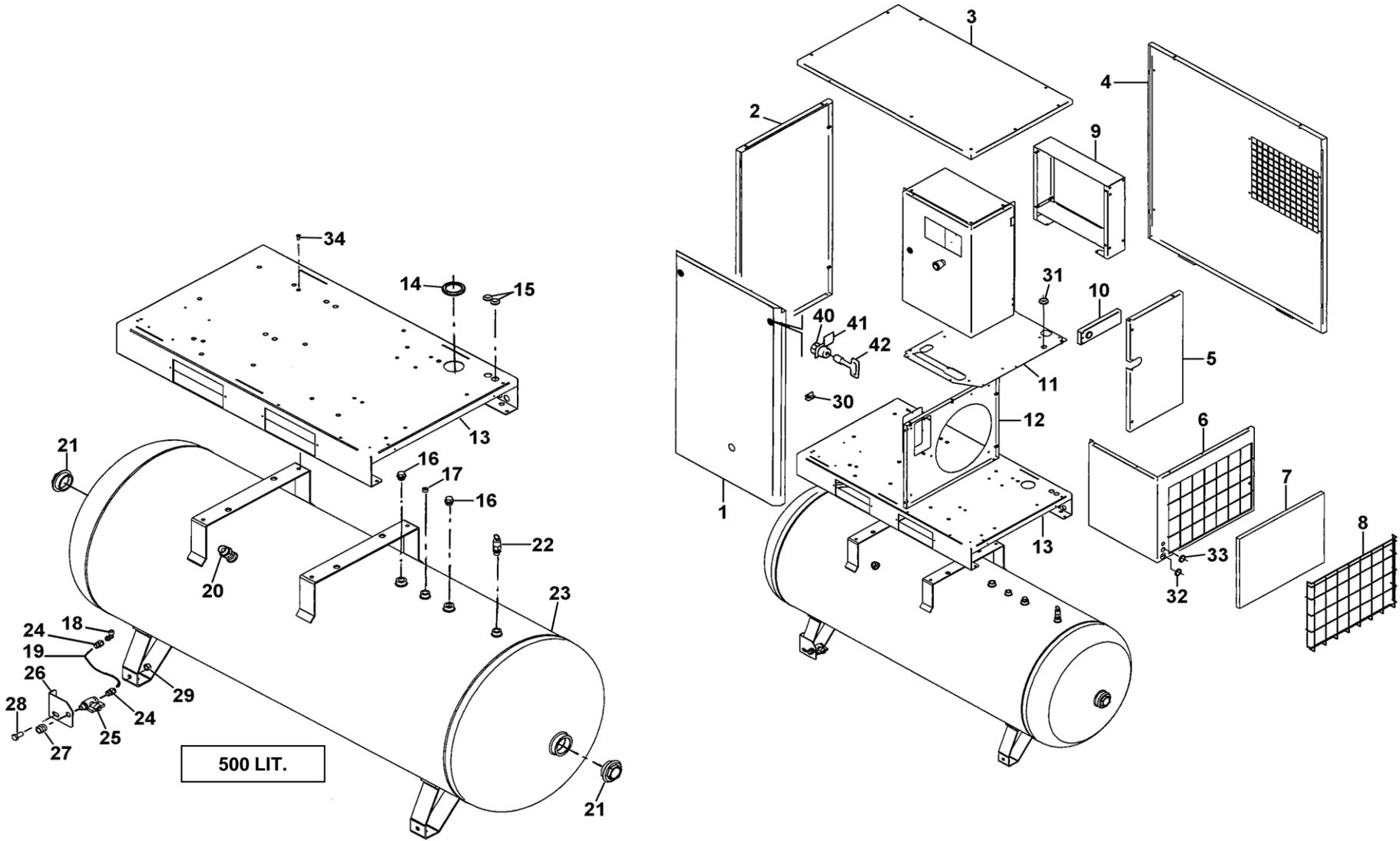











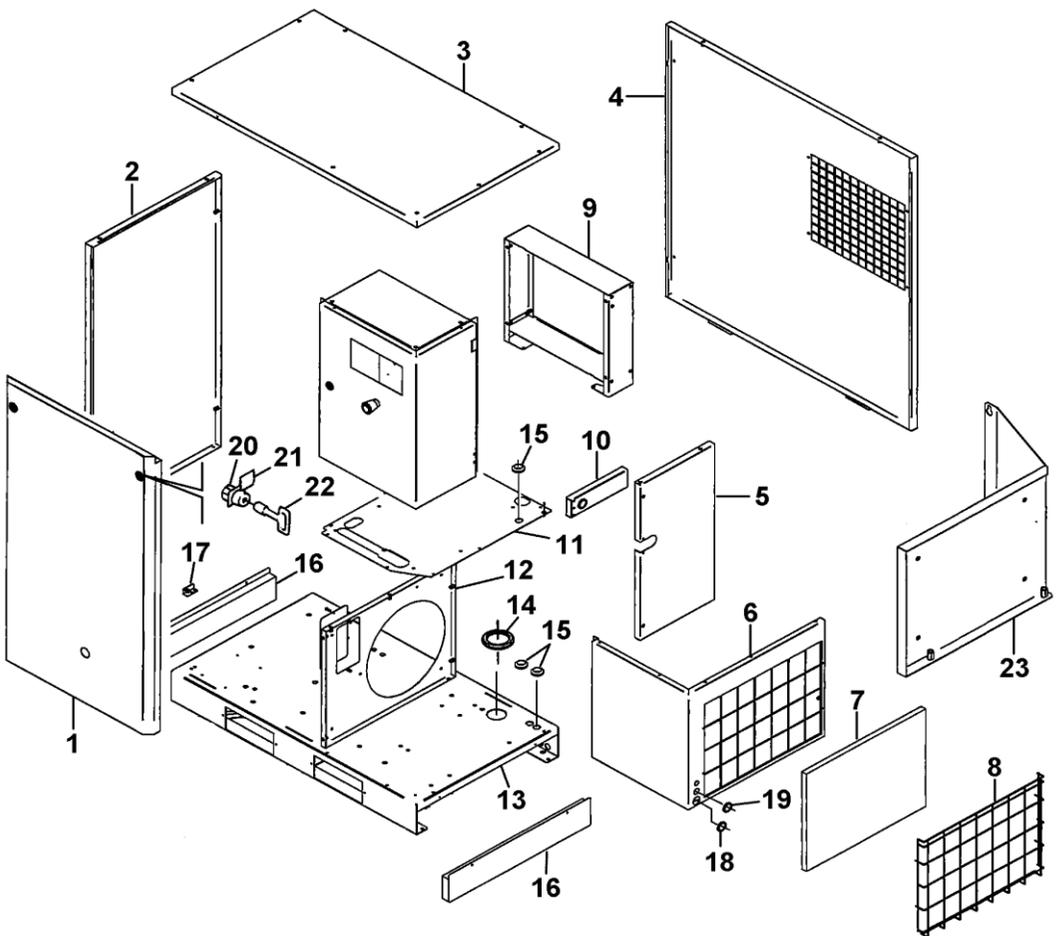



TAB. 3			Q.tà - Qty - Q.té - Anz. - Cant.																				Carenatura - Pannelli fono assorbenti (senza serbatoio) / Casing - Sound-damping panels (without receiver) / Carenage- panneaux insonorisants (sans reservoir) / Stander für die Verkleidung akustische Platten (ohne behälter) / Carenado - Paneles fonoabsorbentes (sin deposito)																
Rif. N. Ref. No Nr. Réf. Bild Nr. Rif. N.	N. ordinaz. Part. num. Nr. Pièce Teil num. Codigo	Nota-Note-Note- Ann.-Nota	HP 7,5 / kW 5,5 (230/60 Hz)				HP 7,5 / kW 5,5 (380-440/60 Hz)				HP 10 / kW 7,5 (230/60 Hz)				HP 10 / kW 7,5 (380-440/60 Hz)				HP 15 / kW 11 (230/60 Hz)				HP 15 / kW 11 (380-440/60 Hz)				DESCRIZIONE - DESCRIPTION - DESIGNATION - BESCHREIBUNG - DESIGNACION												
			4152 0251 60	4152 0251 61	4152 0251 68	4152 0251 69	4152 0252 08	4152 0252 09	4152 0252 16	4152 0252 17	4152 0251 62	4152 0251 63	4152 0251 64	4152 0251 70	4152 0251 71	4152 0251 72	4152 0252 10	4152 0252 11	4152 0252 12	4152 0252 18	4152 0252 19	4152 0252 20	4152 0251 65	4152 0251 66	4152 0251 67	4152 0251 73		4152 0251 74	4152 0251 75	4152 0252 13	4152 0252 14	4152 0252 15	4152 0252 21	4152 0252 22	4152 0252 23				
1	2202 9461 88		1	1	1	1		1	1	1	1		1	1	1	1	1	1	1	1	1		1	1	1	1	1	1	1	1	1	1	1	1	1	PANEL			
2	2203 0583 17		1	1	1	1		1	1	1	1		1	1	1	1	1	1	1	1	1		1	1	1	1	1	1	1	1	1	1	1	1	1	PANEL			
3	2202 9530 16		1	1	1	1		1	1	1	1		1	1	1	1	1	1	1	1	1		1	1	1	1	1	1	1	1	1	1	1	1	1	COVER			
4	2203 0582 17		1	1	1	1		1	1	1	1		1	1	1	1	1	1	1	1	1		1	1	1	1	1	1	1	1	1	1	1	1	1	PANEL			
5	2203 0584 16		1	1	1	1		1	1	1	1		1	1	1	1	1	1	1	1	1		1	1	1	1	1	1	1	1	1	1	1	1	1	PANEL			
6	2202 9533 16		1	1	1	1		1	1	1	1		1	1	1	1	1	1	1	1	1		1	1	1	1	1	1	1	1	1	1	1	1	1	PANEL			
7	2202 2512 10		1	1	1	1		1	1	1	1		1	1	1	1	1	1	1	1	1		1	1	1	1	1	1	1	1	1	1	1	1	1	FILTER ELEMENT			
8	2202 2512 09		1	1	1	1		1	1	1	1		1	1	1	1	1	1	1	1	1		1	1	1	1	1	1	1	1	1	1	1	1	1	GRATING			
9	2202 9475 01		1	1	1	1		1	1	1	1																									STIRRUP SUPPORT COOLER			
9	2202 9475 02												1	1	1	1	1	1	1	1	1														STIRRUP SUPPORT COOLER				
9	2202 9474 00																						1	1	1	1	1	1	1	1	1	1	1	1	1	STIRRUP SUPPORT COOLER			
10	2202 9472 16		1	1	1	1		1	1	1	1		1	1	1	1	1	1	1	1	1		1	1	1	1	1	1	1	1	1	1	1	1	1	STIRRUP SUPPORT			
11	2204 1021 16		1	1	1	1		1	1	1	1		1	1	1	1	1	1	1	1	1		1	1	1	1	1	1	1	1	1	1	1	1	1	BAFFLE UNDER CUBICLE			
12	2202 9470 04		1	1	1	1		1	1	1	1		1	1	1	1	1	1	1	1	1		1	1	1	1	1	1	1	1	1	1	1	1	1	BAFFLE CONVEYOR			
13	2202 9460 16		1	1	1	1		1	1	1	1		1	1	1	1	1	1	1	1	1		1	1	1	1	1	1	1	1	1	1	1	1	1	FRAME			
14	1088 0803 08		1	1	1	1		1	1	1	1		1	1	1	1	1	1	1	1	1		1	1	1	1	1	1	1	1	1	1	1	1	1	GROMMET			
15	0989 4220 08				2	2				2	2					2	2	2																	2	2	2	GROMMET	
16	2202 8941 16		1	1	1	1		1	1	1	1		1	1	1	1	1	1	1	1	1		1	1	1	1	1	1	1	1	1	1	1	1	1	PANEL			
17	2202 9476 00		1	1	1	1		1	1	1	1		1	1	1	1	1	1	1	1	1		1	1	1	1	1	1	1	1	1	1	1	1	1	STIRRUP FOR LEFT PANEL			
18	0989 4220 47		1	1	1	1		1	1	1	1		1	1	1	1	1	1	1	1	1		1	1	1	1	1	1	1	1	1	1	1	1	1	GROMMET			
19	0989 4220 08				1	1				1	1					1	1	1																		1	1	1	GROMMET
20	2200 5402 76		2	2	2	2		2	2	2	2		2	2	2	2	2	2	2	2	2		2	2	2	2	2	2	2	2	2	2	2	2	2	2	DOOR LOCK		
21	2202 2512 59		2	2	2	2		2	2	2	2		2	2	2	2	2	2	2	2	2		2	2	2	2	2	2	2	2	2	2	2	2	2	2	DRAW LATCH		
22	2200 5402 64		1	1	1	1		1	1	1	1		1	1	1	1	1	1	1	1	1		1	1	1	1	1	1	1	1	1	1	1	1	1	1	KEY		
23	2202 9664 04		1	1				1	1				1	1	1		1	1	1				1	1	1				1	1	1					PANEL FAN PROTECTION			

TAB. 3

Q.tà - Qty - Q.té - Anz. - Cant.

Carenatura - Pannelli fono assorbenti (senza serbatoio) / Casing - Sound-damping panels (without receiver) / Carenage-panneaux insonorisants (sans reservoir) / Stander für die Verkleidung akustische Platten (ohne behälter) / Carenado - Paneles fonoabsorbentes (sin deposito)

HP 20 / kW 15 (400/50 Hz)      HP 20 / kW 15 (230/50 Hz)      HP 20 / kW 15 (230/60 Hz)      HP 20 / kW 15 (380-440/60 Hz)

Rif. N. Ref. No Nr. Réf. Bild Nr. Rif. N.	N. ordinaz. Part. num. Nr. Pièce Teil num. Codigo	Nota-Note-Note- Anm.-Nota	4152 0252 74	4152 0252 75	4152 0252 76	4152 0252 77	4152 0252 78	4152 0252 79	4152 0252 56	4152 0252 57	4152 0252 58	4152 0252 59	4152 0252 60	4152 0252 61	4152 0253 16	4152 0253 17	4152 0253 18	4152 0253 19	4152 0253 20	4152 0253 21	4152 0253 34	4152 0253 35	4152 0253 36	4152 0253 37	4152 0253 38	4152 0253 39	DESCRIZIONE - DESCRIPTION - DESIGNATION - BESCHREIBUNG - DESIGNACION
1	2202 9461 88		1	1	1	1	1	1	1	1	1	1	1	1	1	1	1	1	1	1	1	1	1	1	1	PANEL	
2	2203 0583 17		1	1	1	1	1	1	1	1	1	1	1	1	1	1	1	1	1	1	1	1	1	1	1	PANEL	
3	2202 9530 16		1	1	1	1	1	1	1	1	1	1	1	1	1	1	1	1	1	1	1	1	1	1	1	COVER	
4	2203 0582 17		1	1	1	1	1	1	1	1	1	1	1	1	1	1	1	1	1	1	1	1	1	1	1	PANEL	
5	2203 0584 16		1	1	1	1	1	1	1	1	1	1	1	1	1	1	1	1	1	1	1	1	1	1	1	PANEL	
6	2202 9533 16		1	1	1	1	1	1	1	1	1	1	1	1	1	1	1	1	1	1	1	1	1	1	1	PANEL	
7	2202 2512 10		1	1	1	1	1	1	1	1	1	1	1	1	1	1	1	1	1	1	1	1	1	1	1	FILTER ELEMENT	
8	2202 2512 09		1	1	1	1	1	1	1	1	1	1	1	1	1	1	1	1	1	1	1	1	1	1	1	GRATING	
9	2202 9473 00		1	1	1	1	1	1	1	1	1	1	1	1	1	1	1	1	1	1	1	1	1	1	1	STIRRUP SUPPORT COOLER	
10	2202 9472 16		1	1	1	1	1	1	1	1	1	1	1	1	1	1	1	1	1	1	1	1	1	1	1	STIRRUP SUPPORT	
11	2204 1021 16		1	1	1	1	1	1	1	1	1	1	1	1	1	1	1	1	1	1	1	1	1	1	1	BAFFLE UNDER CUBICLE	
12	2202 9470 24		1	1	1	1	1	1	1	1	1	1	1	1	1	1	1	1	1	1	1	1	1	1	1	BAFFLE CONVEYOR	
12	2202 947004														1	1	1	1	1	1	1	1	1	1	1	BAFFLE CONVEYOR	
13	2202 9460 16		1	1	1	1	1	1	1	1	1	1	1	1	1	1	1	1	1	1	1	1	1	1	1	FRAME	
14	1088 0803 08		1	1	1	1	1	1	1	1	1	1	1	1	1	1	1	1	1	1	1	1	1	1	1	GROMMET	
15	0989 4220 08				2	2	2				2	2	2				2	2	2				2	2	2	GROMMET	
16	2202 8941 16		1	1	1	1	1	1	1	1	1	1	1	1	1	1	1	1	1	1	1	1	1	1	1	PANEL	
17	2202 9476 00		1	1	1	1	1	1	1	1	1	1	1	1	1	1	1	1	1	1	1	1	1	1	1	STIRRUP FOR LEFT PANEL	
18	0989 4220 47		1	1	1	1	1	1	1	1	1	1	1	1	1	1	1	1	1	1	1	1	1	1	1	GROMMET	
19	0989 4220 08					1	1	1				1	1	1				1	1	1			1	1	1	GROMMET	
20	2200 5402 76		2	2	2	2	2	2	2	2	2	2	2	2	2	2	2	2	2	2	2	2	2	2	2	DOOR LOCK	
21	2202 2512 59		2	2	2	2	2	2	2	2	2	2	2	2	2	2	2	2	2	2	2	2	2	2	2	DRAW LATCH	
22	2200 5402 64		1	1	1	1	1	1	1	1	1	1	1	1	1	1	1	1	1	1	1	1	1	1	1	KEY	
23	2202 9664 04		1	1	1				1	1	1				1	1	1				1	1	1			PANEL FAN PROTECTION	

Cod. 9828093196 00 - Ediz. - Edil. - Edit. - Ausg. - Edic. 10/2017 - 21

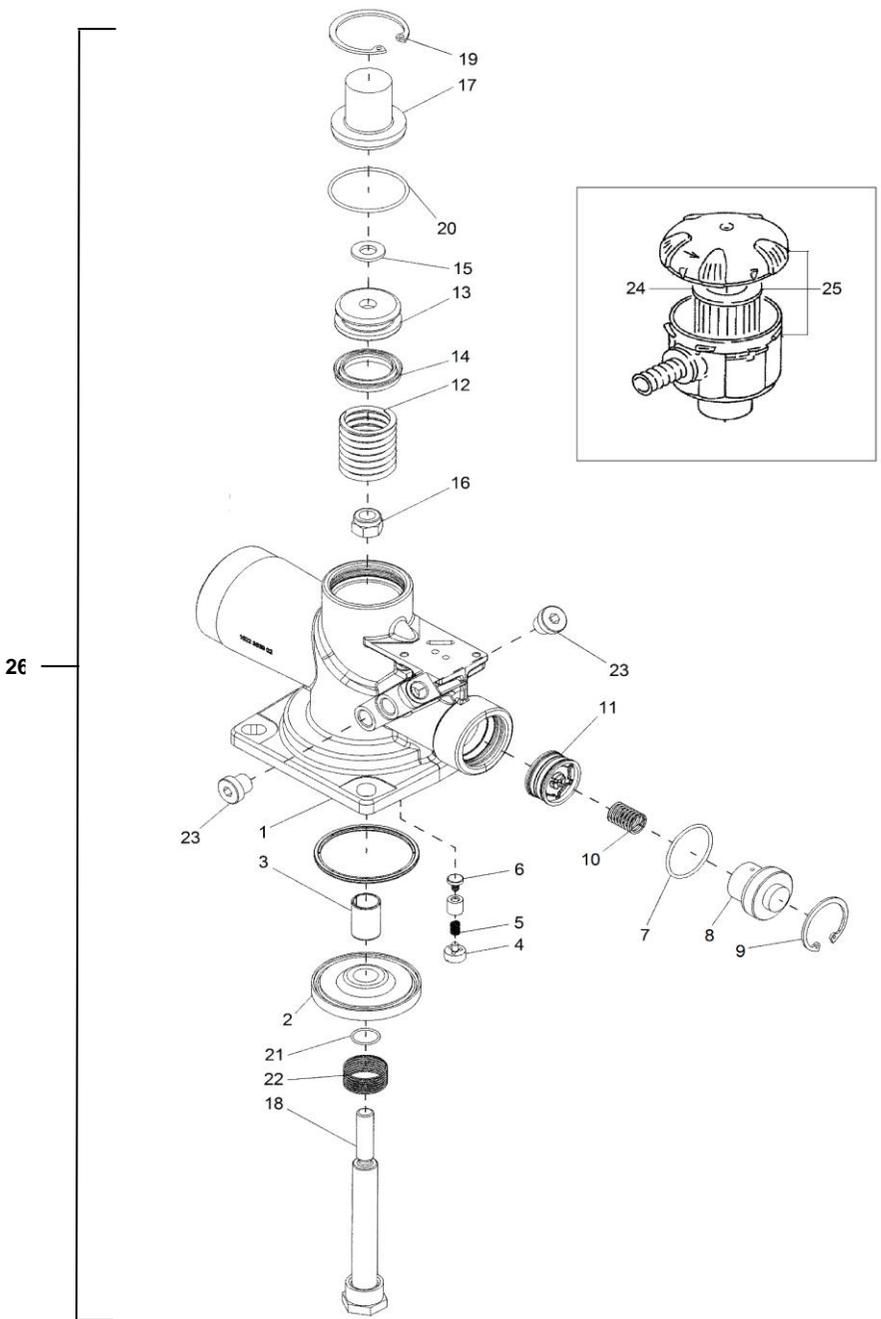

# TAB. 4

## Filtro aspirazione regolatore di portata - Flow regulator intake filter - Filtre d'aspiration régulateur de débit Saugfilter Mengenregler - Filtro de aspiración regulador de caudal Q.tà - Qty - Q.té - Anz. - Cant. HP 7,5 / kW 5,5 (230/50Hz - 400/50 Hz - 230/60Hz - 380-440/60Hz)

### DESCRIZIONE - DESCRIPTION - DESIGNATION - BESCHREIBUNG - DESIGNACION

Rif. N. Ref. No Nr. Réf. Bild Nr. Rif. N.	N. ordinaz. Part. num. Nr. Pièce Teil num. Codigo	Note-Note-Note- Anm.-Nota	4152 0250 64	4152 0250 65	4152 0250 80	4152 0250 81	4152 0250 16	4152 0250 17	4152 0250 32	4152 0250 33	4152 0252 24	4152 0252 25	4152 0252 40	4152 0252 41	4152 0251 76	4152 0251 77	4152 0251 92	4152 0251 93	4152 0250 72	4152 0250 73	4152 0250 88	4152 0250 89	4152 0250 24	4152 0250 25	4152 0250 40	4152 0250 41	4152 0251 12	4152 0251 13	4152 0251 20	4152 0251 21
1	1622 3539 05		1	1	1	1	1	1	1	1	1	1	1	1	1	1	1	1	1	1	1	1	1	1	1	1	1	1	1	1
2	1622 5128 80		1	1	1	1	1	1	1	1	1	1	1	1	1	1	1	1	1	1	1	1	1	1	1	1	1	1	1	1
3	1622 5129 00		1	1	1	1	1	1	1	1	1	1	1	1	1	1	1	1	1	1	1	1	1	1	1	1	1	1	1	1
4	1622 5127 10		1	1	1	1	1	1	1	1	1	1	1	1	1	1	1	1	1	1	1	1	1	1	1	1	1	1	1	1
5	1622 5144 00		1	1	1	1	1	1	1	1	1	1	1	1	1	1	1	1	1	1	1	1	1	1	1	1	1	1	1	1
6	1604 0389 00		1	1	1	1	1	1	1	1	1	1	1	1	1	1	1	1	1	1	1	1	1	1	1	1	1	1	1	1
7	0663 6129 00	•	1	1	1	1	1	1	1	1	1	1	1	1	1	1	1	1	1	1	1	1	1	1	1	1	1	1	1	1
8	1622 5121 00		1	1	1	1	1	1	1	1	1	1	1	1	1	1	1	1	1	1	1	1	1	1	1	1	1	1	1	1
9	0335 2130 00	•	1	1	1	1	1	1	1	1	1	1	1	1	1	1	1	1	1	1	1	1	1	1	1	1	1	1	1	1
10	1622 5122 02	•	1	1	1	1	1	1	1	1	1	1	1	1	1	1	1	1	1	1	1	1	1	1	1	1	1	1	1	1
11	1622 3575 23	•	1	1	1	1	1	1	1	1	1	1	1	1	1	1	1	1	1	1	1	1	1	1	1	1	1	1	1	1
12	1622 5117 00		1	1	1	1	1	1	1	1	1	1	1	1	1	1	1	1	1	1	1	1	1	1	1	1	1	1	1	1
13	1622 5119 00		1	1	1	1	1	1	1	1	1	1	1	1	1	1	1	1	1	1	1	1	1	1	1	1	1	1	1	1
14	1622 5118 00	•	1	1	1	1	1	1	1	1	1	1	1	1	1	1	1	1	1	1	1	1	1	1	1	1	1	1	1	1
15	0301 2135 01		1	1	1	1	1	1	1	1	1	1	1	1	1	1	1	1	1	1	1	1	1	1	1	1	1	1	1	1
16	5541 5510 00		1	1	1	1	1	1	1	1	1	1	1	1	1	1	1	1	1	1	1	1	1	1	1	1	1	1	1	1
17	1622 5120 00		1	1	1	1	1	1	1	1	1	1	1	1	1	1	1	1	1	1	1	1	1	1	1	1	1	1	1	1
18	1622 5115 01		1	1	1	1	1	1	1	1	1	1	1	1	1	1	1	1	1	1	1	1	1	1	1	1	1	1	1	1
19	0335 2136 00	•	1	1	1	1	1	1	1	1	1	1	1	1	1	1	1	1	1	1	1	1	1	1	1	1	1	1	1	1
20	0663 7132 00	•	1	1	1	1	1	1	1	1	1	1	1	1	1	1	1	1	1	1	1	1	1	1	1	1	1	1	1	1
21	0663 2105 13	•	1	1	1	1	1	1	1	1	1	1	1	1	1	1	1	1	1	1	1	1	1	1	1	1	1	1	1	1
22	1622 5116 00	•	1	1	1	1	1	1	1	1	1	1	1	1	1	1	1	1	1	1	1	1	1	1	1	1	1	1	1	1
23	0686 3718 14		2	2	2	2	2	2	2	2	2	2	2	2	2	2	2	2	2	2	2	2	2	2	2	2	2	2	2	2
24	6211 4723 50		1	1	1	1	1	1	1	1	1	1	1	1	1	1	1	1	1	1	1	1	1	1	1	1	1	1	1	1
25	2202 9256 50		1	1	1	1	1	1	1	1	1	1	1	1	1	1	1	1	1	1	1	1	1	1	1	1	1	1	1	1
•	2901 0298 01		1	1	1	1	1	1	1	1	1	1	1	1	1	1	1	1	1	1	1	1	1	1	1	1	1	1	1	1
26	1622 3539 86		1	1	1	1	1	1	1	1	1	1	1	1	1	1	1	1	1	1	1	1	1	1	1	1	1	1	1	1

	HOUSING
	VALVE
	BUSHING
	PLUG
	SPRING
	SEAT
	O-RING
	COVER
	CIRCLIP HOLE
	SPRING
	PISTON
	SPRING
	PISTON
	RING
	PLAIN WASHER
	LOCK NUT
	COVER
	ROD
	CIRCLIP HOLE
	O-RING
	O-RING
	SPRING
	PLUG
	FILTER ELEMENT
	AIR FILTER ASSEMBLY
	KIT UNLOADER
	UNLOADER

<p><b>TAB. 4</b></p>			<p><b>Filtro aspirazione regolatore di portata - Flow regulator intake filter - Filtre d'aspiration régulateur de débit</b>  <b>Saugfilter Mengenregler - Filtro de aspiración regulador de caudal</b></p>																	<p>DESCRIZIONE - DESCRIPTION - DESIGNATION - BESCHREIBUNG - DESIGNACION</p>																												
			<p>Q.tà - Qty - Q.té - Anz. - Cant.</p>																																													
			<p>HP 7,5 / kW 5,5 (230/50Hz - 400/50 Hz - 230/60Hz - 380-440/60Hz)</p>																																													
Rif. N. Ref. No Nr. Réf. Bild Nr. Rif. N.	N. ordinaz. Part. num. Nr. Pièce Teil num. Codigo	Nota-Note-Note- Anm.-Nota	4152 0251 44	4152 0251 45	4152 0251 52	4152 0251 53	4152 0251 84	4152 0251 85	4152 0252 00	4152 0252 01	4152 0252 32	4152 0252 33	4152 0252 48	4152 0252 49	4152 0250 48	4152 0250 49	4152 0250 56	4152 0250 57	4152 0250 00	4152 0250 01	4152 0250 08	4152 0250 09	4152 0251 60	4152 0251 61	4152 0251 68	4152 0251 69	4152 0252 08	4152 0252 09	4152 0252 16	4152 0252 17																		
1	1622 3539 05		1	1	1	1	1	1	1	1	1	1	1	1	1	1	1	1	1	1	1	1	1	1	1	1	1	1	1	1	1	1	1						HOUSING									
2	1622 5128 80		1	1	1	1	1	1	1	1	1	1	1	1	1	1	1	1	1	1	1	1	1	1	1	1	1	1	1	1	1	1	1	1	1	1	1	1			VALVE							
3	1622 5129 00		1	1	1	1	1	1	1	1	1	1	1	1	1	1	1	1	1	1	1	1	1	1	1	1	1	1	1	1	1	1	1	1	1	1	1	1	1			BUSHING						
4	1622 5127 10		1	1	1	1	1	1	1	1	1	1	1	1	1	1	1	1	1	1	1	1	1	1	1	1	1	1	1	1	1	1	1	1	1	1	1	1	1	1			PLUG					
5	1622 5144 00		1	1	1	1	1	1	1	1	1	1	1	1	1	1	1	1	1	1	1	1	1	1	1	1	1	1	1	1	1	1	1	1	1	1	1	1	1	1			SPRING					
6	1604 0389 00		1	1	1	1	1	1	1	1	1	1	1	1	1	1	1	1	1	1	1	1	1	1	1	1	1	1	1	1	1	1	1	1	1	1	1	1	1	1			SEAT					
7	0663 6129 00	•	1	1	1	1	1	1	1	1	1	1	1	1	1	1	1	1	1	1	1	1	1	1	1	1	1	1	1	1	1	1	1	1	1	1	1	1	1	1	1			O-RING				
8	1622 5121 00		1	1	1	1	1	1	1	1	1	1	1	1	1	1	1	1	1	1	1	1	1	1	1	1	1	1	1	1	1	1	1	1	1	1	1	1	1	1	1			COVER				
9	0335 2130 00	•	1	1	1	1	1	1	1	1	1	1	1	1	1	1	1	1	1	1	1	1	1	1	1	1	1	1	1	1	1	1	1	1	1	1	1	1	1	1	1	1			CIRCLIP HOLE			
10	1622 5122 02	•	1	1	1	1	1	1	1	1	1	1	1	1	1	1	1	1	1	1	1	1	1	1	1	1	1	1	1	1	1	1	1	1	1	1	1	1	1	1	1	1			SPRING			
11	1622 3575 23	•	1	1	1	1	1	1	1	1	1	1	1	1	1	1	1	1	1	1	1	1	1	1	1	1	1	1	1	1	1	1	1	1	1	1	1	1	1	1	1	1			PISTON			
12	1622 5117 00		1	1	1	1	1	1	1	1	1	1	1	1	1	1	1	1	1	1	1	1	1	1	1	1	1	1	1	1	1	1	1	1	1	1	1	1	1	1	1	1	1			SPRING		
13	1622 5119 00		1	1	1	1	1	1	1	1	1	1	1	1	1	1	1	1	1	1	1	1	1	1	1	1	1	1	1	1	1	1	1	1	1	1	1	1	1	1	1	1	1			PISTON		
14	1622 5118 00	•	1	1	1	1	1	1	1	1	1	1	1	1	1	1	1	1	1	1	1	1	1	1	1	1	1	1	1	1	1	1	1	1	1	1	1	1	1	1	1	1	1	1			RING	
15	0301 2135 01		1	1	1	1	1	1	1	1	1	1	1	1	1	1	1	1	1	1	1	1	1	1	1	1	1	1	1	1	1	1	1	1	1	1	1	1	1	1	1	1	1			PLAIN WASHER		
16	5541 5510 00		1	1	1	1	1	1	1	1	1	1	1	1	1	1	1	1	1	1	1	1	1	1	1	1	1	1	1	1	1	1	1	1	1	1	1	1	1	1	1	1	1	1			LOCK NUT	
17	1622 5120 00		1	1	1	1	1	1	1	1	1	1	1	1	1	1	1	1	1	1	1	1	1	1	1	1	1	1	1	1	1	1	1	1	1	1	1	1	1	1	1	1	1	1			COVER	
18	1622 5115 01		1	1	1	1	1	1	1	1	1	1	1	1	1	1	1	1	1	1	1	1	1	1	1	1	1	1	1	1	1	1	1	1	1	1	1	1	1	1	1	1	1	1			ROD	
19	0335 2136 00	•	1	1	1	1	1	1	1	1	1	1	1	1	1	1	1	1	1	1	1	1	1	1	1	1	1	1	1	1	1	1	1	1	1	1	1	1	1	1	1	1	1	1			CIRCLIP HOLE	
20	0663 7132 00	•	1	1	1	1	1	1	1	1	1	1	1	1	1	1	1	1	1	1	1	1	1	1	1	1	1	1	1	1	1	1	1	1	1	1	1	1	1	1	1	1	1	1			O-RING	
21	0663 2105 13	•	1	1	1	1	1	1	1	1	1	1	1	1	1	1	1	1	1	1	1	1	1	1	1	1	1	1	1	1	1	1	1	1	1	1	1	1	1	1	1	1	1	1			O-RING	
22	1622 5116 00	•	1	1	1	1	1	1	1	1	1	1	1	1	1	1	1	1	1	1	1	1	1	1	1	1	1	1	1	1	1	1	1	1	1	1	1	1	1	1	1	1	1	1			SPRING	
23	0686 3718 14		2	2	2	2	2	2	2	2	2	2	2	2	2	2	2	2	2	2	2	2	2	2	2	2	2	2	2	2	2	2	2	2	2	2	2	2	2	2	2	2	2	2	2			PLUG
24	6211 4723 50		1	1	1	1	1	1	1	1	1	1	1	1	1	1	1	1	1	1	1	1	1	1	1	1	1	1	1	1	1	1	1	1	1	1	1	1	1	1	1	1	1	1			FILTER ELEMENT	
25	2202 9256 50		1	1	1	1	1	1	1	1	1	1	1	1	1	1	1	1	1	1	1	1	1	1	1	1	1	1	1	1	1	1	1	1	1	1	1	1	1	1	1	1	1	1			AIR FILTER ASSEMBLY	
	• 2901 0298 01		1	1	1	1	1	1	1	1	1	1	1	1	1	1	1	1	1	1	1	1	1	1	1	1	1	1	1	1	1	1	1	1	1	1	1	1	1	1	1	1	1	1			KIT UNLOADER	
26	1622 3539 86		1	1	1	1	1	1	1	1	1	1	1	1	1	1	1	1	1	1	1	1	1	1	1	1	1	1	1	1	1	1	1	1	1	1	1	1	1	1	1	1	1	1			UNLOADER	















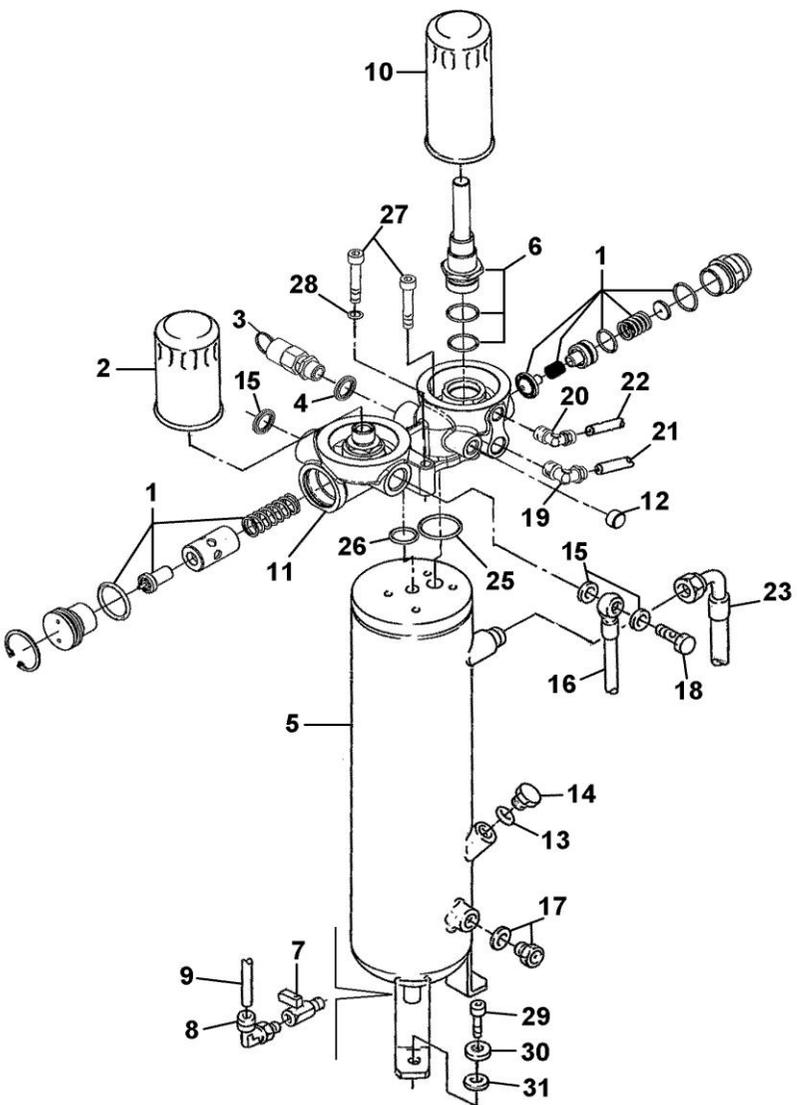

**TAB. 5**

**Serbatoio-separatore aria/olio raffreddatore aria/olio Reservoir-separateur air/huile refroidisseur air/huile / Air/oil tank-separator air/oil cooler / Reservoir-separateur air/huile refroidisseur air/huile / Luft/Öl Behälter-Abscheider Luft/Öl / Depósito de aceite separador aire/aceite refrigerador aire/aceite**

Q.tà - Qty - Q.té - Anz. - Cant.

HP 7,5 / kW 5,5 (230/50Hz - 400/50 Hz - 230/60Hz - 380-440/60Hz)

DESCRIZIONE - DESCRIPTION - DESIGNATION - BESCHREIBUNG - DESIGNACION

Rif. N. Ref. No Nr. Rêf. Bild Nr. Rif. N.	N. ordinaz. Part. num. Nr. Pièce Teil num. Codigo	Note-Note-Note- Anm.-Nota	4152 0250 64	4152 0250 65	4152 0250 80	4152 0250 81	4152 0250 16	4152 0250 17	4152 0250 32	4152 0250 33	4152 0252 24	4152 0252 25	4152 0252 40	4152 0252 41	4152 0251 76	4152 0251 77	4152 0251 92	4152 0251 93	4152 0250 72	4152 0250 73	4152 0250 88	4152 0250 89	4152 0250 24	4152 0250 25	4152 0250 40	4152 0250 41	4152 0251 12	4152 0251 13	4152 0251 20	4152 0251 21						
1	2901 1095 00		1	1	1	1	1	1	1	1	1	1	1	1	1	1	1	1	1	1	1	1	1	1	1	1	1	1	1	1						KIT THERMOSTATIC VALVE / KIT MINIMUM PRESSURE VALVE
2	6211 4726 50		1	1	1	1	1	1	1	1	1	1	1	1	1	1	1	1	1	1	1	1	1	1	1	1	1	1	1	1						OIL FILTER
3	2202 8891 01		1	1	1	1	1	1	1	1	1	1	1	1	1	1	1	1	1	1	1	1	1	1	1	1	1	1	1	1						SAFETY VALVE
4	0661 1000 40		1	1	1	1	1	1	1	1	1	1	1	1	1	1	1	1	1	1	1	1	1	1	1	1	1	1	1	1						WASHER
5	2202 2512 16		1	1	1	1	1	1	1	1	1	1	1	1	1	1	1	1	1	1	1	1	1	1	1	1	1	1	1	1						OIL TANK
6	2200 7517 35		1	1	1	1	1	1	1	1	1	1	1	1	1	1	1	1	1	1	1	1	1	1	1	1	1	1	1	1						KIT NIPPLE-OR
7	0852 0010 45		1	1	1	1	1	1	1	1	1	1	1	1	1	1	1	1	1	1	1	1	1	1	1	1	1	1	1	1						DRAIN COCK
8	0583 8120 22		1	1	1	1	1	1	1	1	1	1	1	1	1	1	1	1	1	1	1	1	1	1	1	1	1	1	1	1						ELBOW UNION
9	0070 6002 15		X	X	X	X	X	X	X	X	X	X	X	X	X	X	X	X	X	X	X	X	X	X	X	X	X	X	X	X						HOSE (IN METERS)
10	6221 3728 50		1	1	1	1	1	1	1	1	1	1	1	1	1	1	1	1	1	1	1	1	1	1	1	1	1	1	1	1						SEPARATOR AIR-OIL
11	2202 9992 03		1	1	1	1	1	1	1	1	1	1	1	1	1	1	1	1	1	1	1	1	1	1	1	1	1	1	1	1						VALVES ASSEMBLY
12	0686 3718 12		1	1	1	1	1	1	1	1	1	1	1	1	1	1	1	1	1	1	1	1	1	1	1	1	1	1	1	1						PLUG
13	0663 2105 90		1	1	1	1	1	1	1	1	1	1	1	1	1	1	1	1	1	1	1	1	1	1	1	1	1	1	1	1						O-RING
14	2202 2124 21		1	1	1	1	1	1	1	1	1	1	1	1	1	1	1	1	1	1	1	1	1	1	1	1	1	1	1	1						PLUG
15	0661 1000 39		3	3	3	3	3	3	3	3	3	3	3	3	3	3	3	3	3	3	3	3	3	3	3	3	3	3	3	3						WASHER
16	2202 7050 07		1	1	1	1	1	1	1	1	1	1	1	1	1	1	1	1	1	1	1	1	1	1	1	1	1	1	1	1						FLEXIBLE TUBE
17	2200 7599 10		1	1	1	1	1	1	1	1	1	1	1	1	1	1	1	1	1	1	1	1	1	1	1	1	1	1	1	1						OIL GAUGE
18	0627 5100 05		1	1	1	1	1	1	1	1	1	1	1	1	1	1	1	1	1	1	1	1	1	1	1	1	1	1	1	1						SCREW
19	2202 7639 01		1	1	1	1	1	1	1	1	1	1	1	1	1	1	1	1	1	1	1	1	1	1	1	1	1	1	1	1						ELBOW UNION
20	9740 2004 32		1	1	1	1	1	1	1	1	1	1	1	1	1	1	1	1	1	1	1	1	1	1	1	1	1	1	1	1						ELBOW UNION
21	0070 6002 09		X	X	X	X	X	X	X	X	X	X	X	X	X	X	X	X	X	X	X	X	X	X	X	X	X	X	X	X						HOSE (IN METERS)
22	0070 6002 48		X	X	X	X	X	X	X	X	X	X	X	X	X	X	X	X	X	X	X	X	X	X	X	X	X	X	X	X						HOSE (IN METERS)
23	2202 7050 05		1	1	1	1	1	1	1	1	1	1	1	1	1	1	1	1	1	1	1	1	1	1	1	1	1	1	1	1						FLEXIBLE TUBE
25	2204 1321 02		1	1	1	1	1	1	1	1	1	1	1	1	1	1	1	1	1	1	1	1	1	1	1	1	1	1	1	1						O-RING
26	2204 1321 01		1	1	1	1	1	1	1	1	1	1	1	1	1	1	1	1	1	1	1	1	1	1	1	1	1	1	1	1						O-RING
27	0211 1329 03		4	4	4	4	4	4	4	4	4	4	4	4	4	4	4	4	4	4	4	4	4	4	4	4	4	4	4	4						SCREW
28	0333 3100 17		2	2	2	2	2	2	2	2	2	2	2	2	2	2	2	2	2	2	2	2	2	2	2	2	2	2	2	2						WASHER
29	0211 1325 03		2	2	2	2	2	2	2	2	2	2	2	2	2	2	2	2	2	2	2	2	2	2	2	2	2	2	2	2						SCREW
30	0333 4232 00		2	2	2	2	2	2	2	2	2	2	2	2	2	2	2	2	2	2	2	2	2	2	2	2	2	2	2	2						WASHER
31	0300 8019 00		2	2	2	2	2	2	2	2	2	2	2	2	2	2	2	2	2	2	2	2	2	2	2	2	2	2	2	2						WASHER

















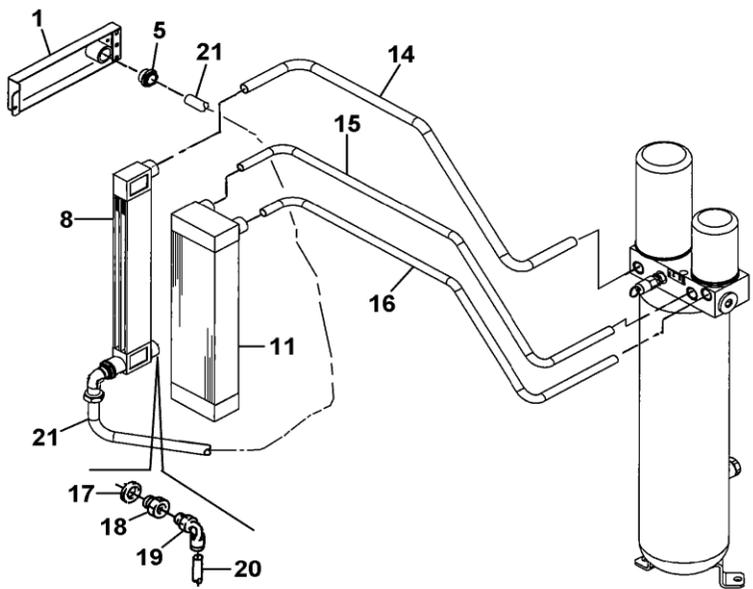
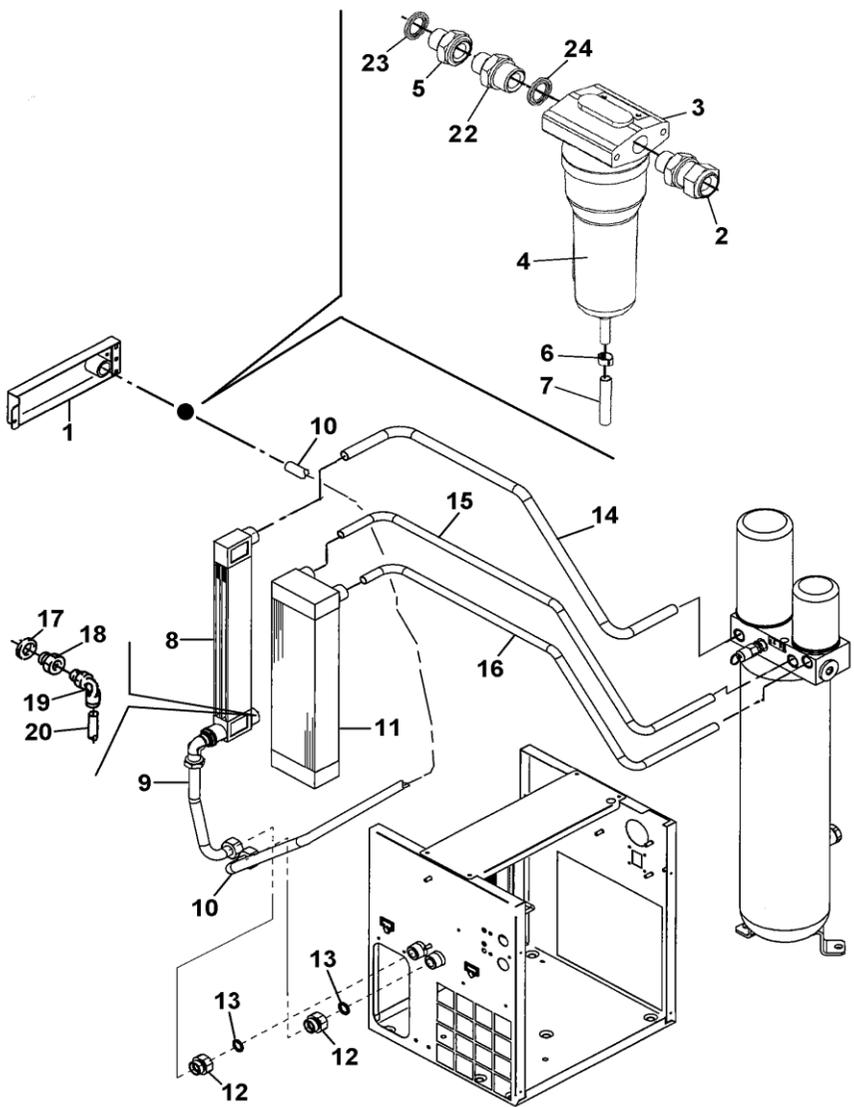

**TAB. 6**

Q.tà - Qty - Q.té - Anz. - Cant.

**Rraffreddatore aria-olio / Refroidisseur air/huile / Air-oil cooler / Refroidisseur air/huile / Abscheider Luft-Öl / Refrigerador aire/aceite**

HP 7,5 / kW 5,5  
(400/50 Hz - 380-440/60Hz)

HP 7,5 / kW 5,5  
(230/50 Hz - 230/60Hz)

Rif. N. Ref. No Nr. Réf. Bild Nr. Rif. N.	N. ordinaz. Part. num. Nr. Pièce Teil num. Codigo	Nota-Note-Note- Ann.-Nota	4152 0250 48	4152 0250 49	4152 0250 56	4152 0250 57	4152 0252 08	4152 0252 09	4152 0252 16	4152 0252 17	4152 0250 00	4152 0250 01	4152 0250 08	4152 0250 09	4152 0251 60	4152 0251 61	4152 0251 68	4152 0251 69	DESCRIZIONE - DESCRIPTION - DESIGNATION - BESCHREIBUNG - DESIGNACION	
1	2202 9472 16		1	1	1	1	1	1	1	1	1	1	1	1	1	1	1	1	STIRRUP	
2	0580 0014 52				1	1					1	1					1	1	NIPPLE	
3	8102 8425 34				1	1						1	1						FILTER ASSEMBLY	
4	2258 2901 14				1	1							1	1					FILTER ELEMENT	
5	2202 8858 00		1	1	1	1	1	1	1	1	1	1	1	1	1	1	1	1	REDUCTION	
6	0347 6103 00				1	1							1	1					HOSE CLAMP	
7	0070 6002 49				1	1							1	1					HOSE (IN METERS)	
8	2202 8302 01		1	1	1	1	1	1	1	1	1	1	1	1	1	1	1	1	AIR COOLER	
9	2202 9486 00				1	1							1	1					PIPE AIR DRYER (IN)	
10	2202 9456 01				1	1							1	1					PIPE AIR DRYER (OUT)	
11	1091 6319 32		1	1	1	1	1	1	1	1	1	1	1	1	1	1	1	1	OIL COOLER	
12	2202 9264 00				2	2							2	2				2	2	ADAPTER
13	0661 1000 40				2	2							2	2					SEAL WASHER	
14	2202 9485 00		1	1	1	1	1	1	1	1	1	1	1	1	1	1	1	1	PIPE AIR OUTLET	
15	2202 9484 00		1	1	1	1	1	1	1	1	1	1	1	1	1	1	1	1	PIPE OIL DELIVERY	
16	2202 9483 00		1	1	1	1	1	1	1	1	1	1	1	1	1	1	1	1	PIPE OIL RETURN	
17	0661 1000 39		1	1	1	1	1	1	1	1	1	1	1	1	1	1	1	1	WASHER	
18	2200 7505 48		1	1	1	1	1	1	1	1	1	1	1	1	1	1	1	1	REDUCTION	
19	9090 1519 00		1	1	1	1	1	1	1	1	1	1	1	1	1	1	1	1	ELBOW UNION	
20	0070 7250 04		X	X	X	X	X	X	X	X	X	X	X	X	X	X	X	X	HOSE (IN METERS)	
21	2202 9459 00		1	1			1	1			1	1			1	1			PIPE AIR OUTLET	
22	1503 1225 00				1	1							1	1					NIPPLE	
23	0661 1000 43				1	1							1	1					SEAL WASHER	
24	0661 1000 39				1	1							1	1					SEAL WASHER	





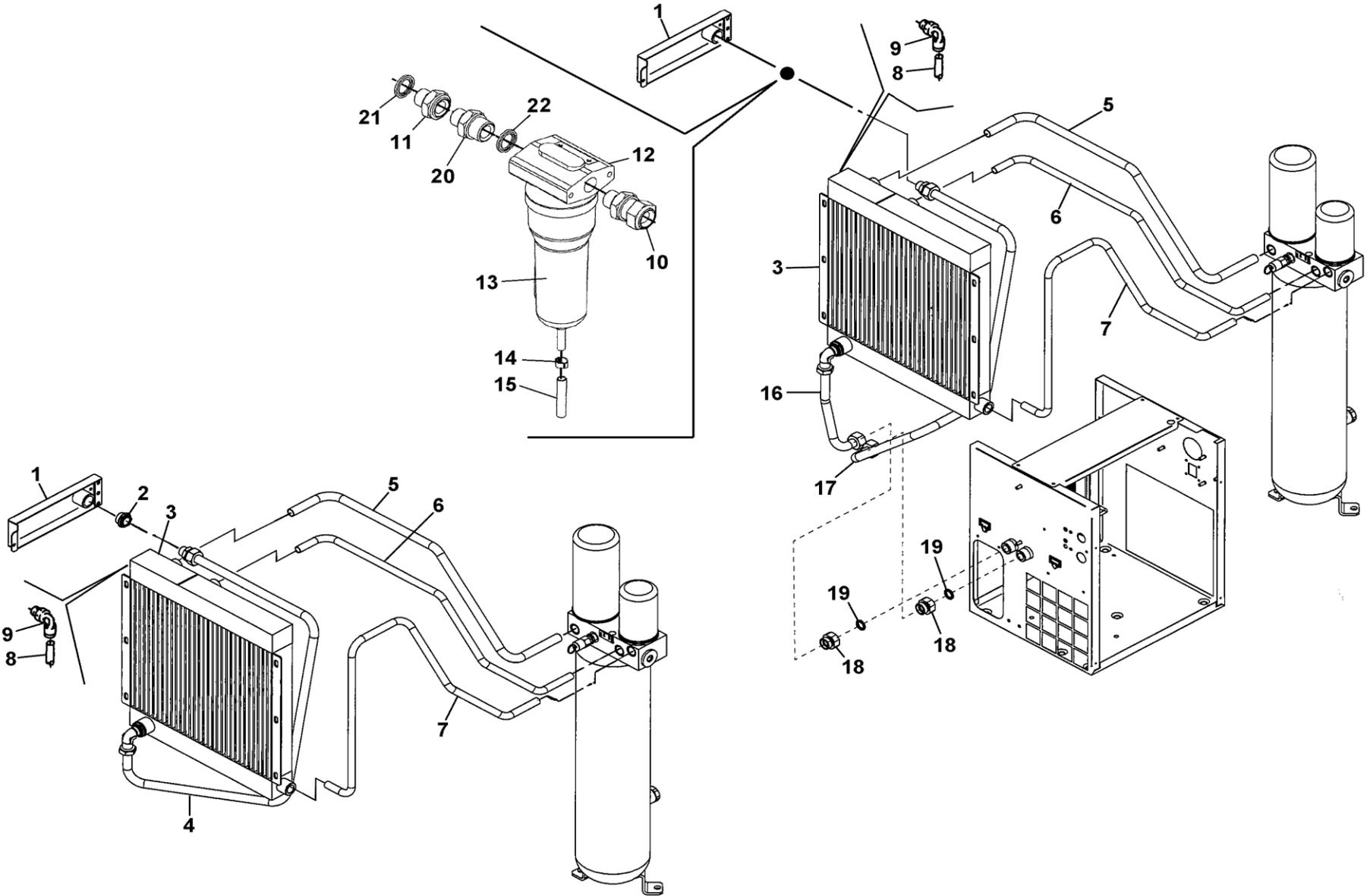

# TAB. 7

Q.tà - Qty - Q.té - Anz. - Cant.

**Raffreddatore aria-olio / Refroidisseur air/huile / Air-oil cooler / Refroidisseur air/huile / Abscheider Luft-Öl / Refrigerador aire/aceite**

HP 15 / kW 11  
(400/50 Hz - 380-440/60Hz)

HP 15 / kW 11  
(230/50 Hz - 230/60Hz)

Rif. N. Ref. No Nr. Réf. Bild Nr. Rif. N.	N. ordinaz. Part. num. Nr. Pièce Teil num. Codigo	Nota-Note-Note- Ann.-Nota	HP 15 / kW 11 (400/50 Hz - 380-440/60Hz)											HP 15 / kW 11 (230/50 Hz - 230/60Hz)											DESCRIZIONE - DESCRIPTION - DESIGNATION - BESCHREIBUNG - DESIGNACION				
			4152 0250 53	4152 0250 54	4152 0250 55	4152 0250 61	4152 0250 62	4152 0250 63	4152 0252 13	4152 0252 14	4152 0252 15	4152 0252 21	4152 0252 22	4152 0252 23	4152 0250 05	4152 0250 06	4152 0250 07	4152 0250 13	4152 0250 14	4152 0250 15	4152 0251 65	4152 0251 66	4152 0251 67	4152 0251 73		4152 0251 74	4152 0251 75		
1	2202 9472 16		1	1	1	1	1	1	1	1	1	1				1	1	1	1	1	1	1	1	1				STIRRUP	
2	2202 8858 00		1	1	1							1	1	1						1	1	1						REDUCTION	
3	2202 8588 01		1	1	1	1	1	1	1	1	1	1	1	1	1	1	1	1	1	1	1	1	1	1	1	1		AIR-OIL COOLER	
4	2202 9459 00		1	1	1						1	1	1						1	1	1							PIPE AIR OUT	
5	2202 9482 00		1	1	1	1	1	1	1	1	1	1	1	1	1	1	1	1	1	1	1	1	1	1	1	1		PIPE AIR OUTLET	
6	2202 9481 00		1	1	1	1	1	1	1	1	1	1	1	1	1	1	1	1	1	1	1	1	1	1	1	1	1	1	PIPE OIL DELIVERY
7	2202 9480 02		1	1	1	1	1	1	1	1	1	1	1	1	1	1	1	1	1	1	1	1	1	1	1	1	1	1	PIPE OIL RETURN
8	0070 7250 04	X	X	X	X	X	X	X	X	X	X	X	X	X	X	X	X	X	X	X	X	X	X	X	X	X	X	X	HOSE (IN METERS)
9	9090 1519 00		1	1	1	1	1	1	1	1	1	1	1	1	1	1	1	1	1	1	1	1	1	1	1	1	1	1	ELBOW UNION
10	0580 0014 52					1	1	1	1	1	1	1	1	1	1	1	1	1	1	1	1	1	1	1	1	1	1	1	NIPPLE
11	2202 8858 00					1	1	1					1	1	1							1	1	1				REDUCTION	
12	8102 8425 34					1	1	1					1	1	1							1	1	1				FILTER ASSEMBLY	
13	2258 2901 14					1	1	1					1	1	1							1	1	1				FILTER ELEMENT	
14	0347 6103 00					1	1	1					1	1	1							1	1	1				HOSE CLAMP	
15	0070 6002 49					1	1	1					1	1	1							1	1	1				HOSE (IN METERS)	
16	2202 9486 00					1	1	1					1	1	1							1	1	1				PIPE AIR DRYER (IN)	
17	2202 9456 01					1	1	1					1	1	1							1	1	1				PIPE AIR DRYER (OUT)	
18	2202 9264 00					2	2	2					2	2	2							2	2	2				ADAPTER	
19	0661 1000 40					2	2	2					2	2	2							2	2	2				SEAL WASHER	
20	1503 1225 00					1	1	1					1	1	1							1	1	1				NIPPLE	
21	0661 1000 43					1	1	1					1	1	1							1	1	1				SEAL WASHER	
22	0661 1000 39					1	1	1					1	1	1							1	1	1				SEAL WASHER	





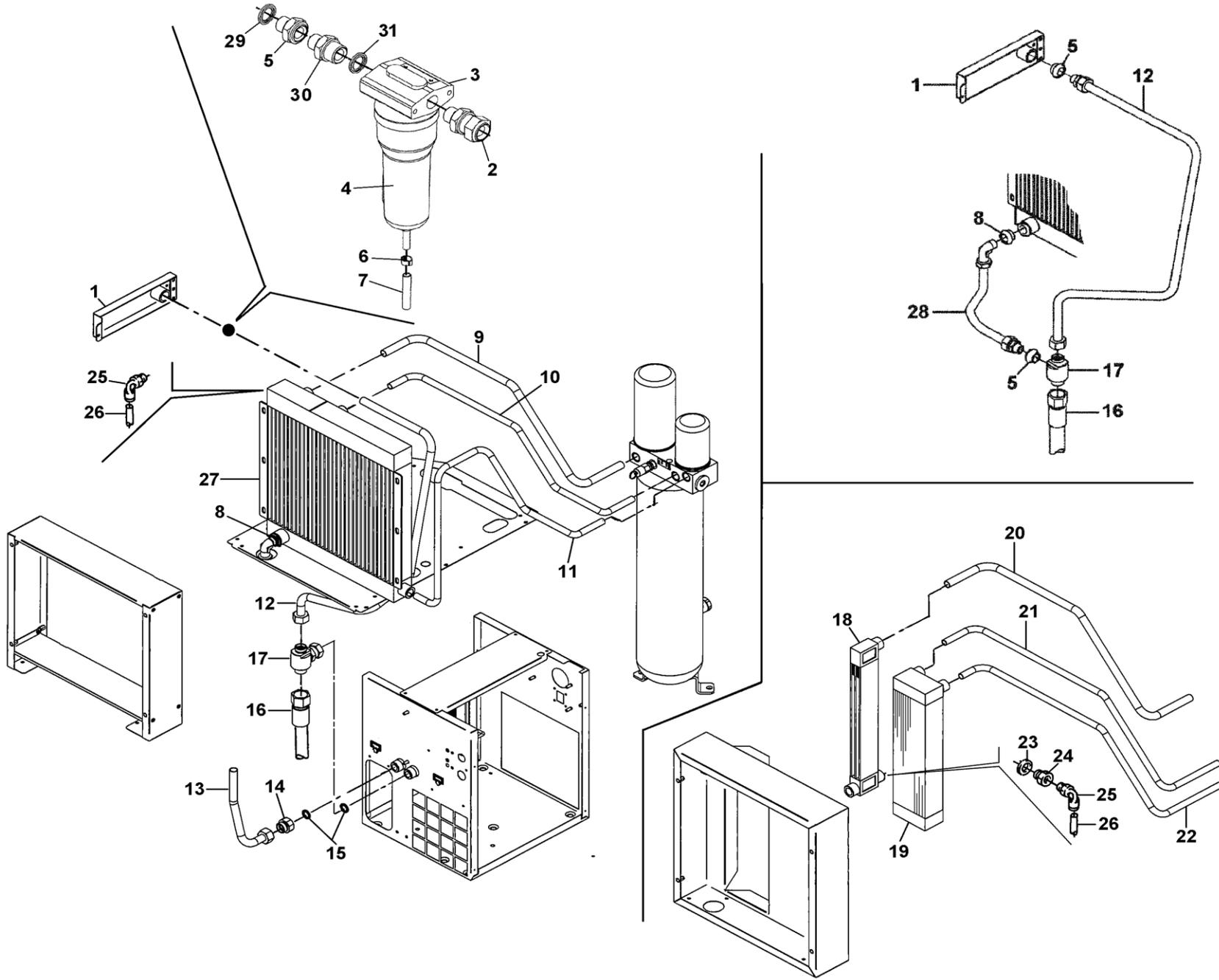

**TAB. 8**

Q.tà - Qty - Qté - Anz. - Cant. **(270 Lit.)**

HP 7,5 / kW 5,5  
(400/50 Hz - 380-440/60Hz)

HP 7,5 / kW 5,5  
(230/50 Hz - 230/60Hz)

**Rraffreddatore aria-olio / Refroidisseur air/huile / Air-oil cooler / Refroidisseur air/huile /  
Abscheider Luft-Öl / Refrigerador aire/aceite**

Rif. N. Ref. No Nr. Rêf. Bild Nr. Rif. N.	N. ordinaz. Part. num. Nr. Pièce Teil num. Codigo	Note-Note- Anm.-Nota	4152 0250 64	4152 0250 65	4152 0250 80	4152 0250 81	4152 0252 24	4152 0252 25	4152 0252 40	4152 0252 41							4152 0250 16	4152 0250 17	4152 0250 32	4152 0250 33	4152 0251 76	4152 0251 77	4152 0251 92	4152 0251 93							DESCRIZIONE - DESCRIPTION - DESIGNATION - BESCHREIBUNG - DESIGNACION										
1	2202 9472 16		1	1	1	1	1	1	1	1							1	1	1	1	1	1	1	1						STIRRUP											
2	0580 0014 52				1	1				1	1								1	1			1	1						NIPPLE											
3	8102 8425 34				1	1				1	1								1	1			1	1						FILTER ASSEMBLY											
4	2258 2901 14				1	1				1	1								1	1			1	1						FILTER ELEMENT											
5	2202 8858 00		2	2	2	2	2	2	2	2	2						2	2	2	2	2	2	2	2						REDUCTION											
6	0347 6103 00				1	1				1	1								1	1			1	1						HOSE CLAMP											
7	0070 6002 49				1	1				1	1								1	1			1	1						HOSE (IN METERS)											
12	2202 9754 00		1	1			1	1									1	1			1	1								PIPE AIR DRYER (OUT)											
12	2202 9487 01				1	1				1	1								1	1			1	1						PIPE AIR DRYER (OUT)											
13	2202 9486 00				1	1				1	1								1	1			1	1						PIPE AIR DRYER (IN)											
14	2202 9264 00				1	1				1	1								1	1			1	1						ADAPTER											
15	0661 1000 40				2	2				2	2								2	2			2	2						SEAL WASHER											
16	2202 8681 07		1	1	1	1	1	1	1	1	1						1	1	1	1	1	1	1	1						FLEXIBLE TUBE											
17	2202 9458 00		1	1			1	1									1	1			1	1								TEE ASS.											
17	2202 9458 80				1	1				1	1								1	1			1	1						TEE ASS.											
18	2202 8302 01		1	1	1	1	1	1	1	1	1						1	1	1	1	1	1	1	1						AIR COOLER											
19	1091 6319 32		1	1	1	1	1	1	1	1	1						1	1	1	1	1	1	1	1						OIL COOLER											
20	2202 9485 00		1	1	1	1	1	1	1	1	1						1	1	1	1	1	1	1	1						PIPE AIR OUTLET											
21	2202 9484 00		1	1	1	1	1	1	1	1	1						1	1	1	1	1	1	1	1						PIPE OIL DELIVERY											
22	2202 9483 00		1	1	1	1	1	1	1	1	1						1	1	1	1	1	1	1	1						PIPE OIL RETURN											
23	0661 1000 39		1	1	1	1	1	1	1	1	1						1	1	1	1	1	1	1	1						WASHER											
24	2200 7505 48		1	1	1	1	1	1	1	1	1						1	1	1	1	1	1	1	1						REDUCTION											
25	9090 1519 00		1	1	1	1	1	1	1	1	1						1	1	1	1	1	1	1	1						ELBOW UNION											
26	0070 7250 04		1	1	1	1	1	1	1	1	1						1	1	1	1	1	1	1	1						HOSE (IN METERS)											
28	2202 9753 00		1	1			1	1									1	1			1	1								PIPE AIR											



**TAB. 8**

Q.tà - Qty - Qté - Anz. - Cant. (270 Lit.)

**Raffreddatore aria-olio / Refroidisseur air/huile / Air-oil cooler / Refroidisseur air/huile / Abscheider Luft-Öl / Refrigerador aire/aceite**

HP 15 / kW 11  
(400/50 Hz - 380-440/60Hz)

HP 15 / kW 11  
(230/50 Hz - 230/60Hz)

DESCRIZIONE - DESCRIPTION - DESIGNATION - BESCHREIBUNG - DESIGNACION

Rif. N. Ref. No Nr. Réf. Bild Nr. Rif. N.	N. ordinaz. Part. num. Nr. Pièce Teil num. Codigo	Nota-Note-Note- Anm.-Nota	4152 0250 69	4152 0250 70	4152 0250 85	4152 0250 86	4152 0250 87	4152 0252 29	4152 0252 30	4152 0252 31	4152 0252 45	4152 0252 46	4152 0252 47	4152 0250 21	4152 0250 22	4152 0250 23	4152 0250 37	4152 0250 38	4152 0250 39	4152 0251 81	4152 0251 82	4152 0251 83	4152 0250 37	4152 0250 38	4152 0250 39	4152 0251 97	4152 0251 98	4152 0251 99					
1	2202 9472 16		1	1	1	1	1	1	1	1	1	1	1	1	1	1	1	1	1	1	1	1	1	1	1	1	1	1	1	1	1	1	STIRRUP
2	0603 4105 03				1	1	1			1	1	1				1	1	1					1	1	1	1	1	1	1	1	1	NIPPLE	
3	8102 8425 34				1	1	1			1	1	1				1	1	1					1	1	1	1	1	1	1	1	1	FILTER ASSEMBLY	
4	2258 2901 14				1	1	1			1	1	1				1	1	1					1	1	1	1	1	1	1	1	1	FILTER ELEMENT	
5	2202 8858 00		2	2	2	2	2	2	2	2	2	2	2	2	2	2	2	2	2	2	2	2	2	2	2	2	2	2	2	2	2	2	REDUCTION
6	0347 6103 00				1	1	1			1	1	1				1	1	1					1	1	1	1	1	1	1	1	1	HOSE CLAMP	
7	0070 6002 49				1	1	1			1	1	1				1	1	1					1	1	1	1	1	1	1	1	1	HOSE (IN METERS)	
8	2202 8858 00		1	1	1	1	1	1	1	1	1	1	1	1	1	1	1	1	1	1	1	1	1	1	1	1	1	1	1	1	1	REDUCTION	
9	2202 9482 00		1	1	1	1	1	1	1	1	1	1	1	1	1	1	1	1	1	1	1	1	1	1	1	1	1	1	1	1	1	1	PIPE AIR OUTLET
10	2202 9481 00		1	1	1	1	1	1	1	1	1	1	1	1	1	1	1	1	1	1	1	1	1	1	1	1	1	1	1	1	1	1	PIPE OIL DELIVERY
11	2202 9480 02		1	1	1	1	1	1	1	1	1	1	1	1	1	1	1	1	1	1	1	1	1	1	1	1	1	1	1	1	1	1	PIPE OIL RETURN
12	2202 9754 00		1	1	1			1	1	1				1	1	1					1	1	1										PIPE AIR DRYER (OUT)
12	2202 9487 01				1	1	1			1	1	1		1	1	1	1	1	1	1	1	1	1	1	1	1	1	1	1	1	1	1	PIPE AIR DRYER (OUT)
13	2202 9486 00				1	1	1			1	1	1			1	1	1						1	1	1	1	1	1	1	1	1	1	PIPE AIR DRYER (IN)
14	2202 9264 00				1	1	1			1	1	1				1	1	1					1	1	1	1	1	1	1	1	1	1	ADAPTER
15	0661 1000 40				2	2	2			2	2	2				2	2	2					2	2	2	2	2	2	2	2	2	2	SEAL WASHER
16	2202 8681 07		1	1	1	1	1	1	1	1	1	1	1	1	1	1	1	1	1	1	1	1	1	1	1	1	1	1	1	1	1	1	FLEXIBLE TUBE
17	2202 9458 00		1	1	1			1	1	1				1	1	1				1	1	1											TEE ASS.
17	2202 9458 80				1	1	1			1	1	1				1	1	1					1	1	1	1	1	1	1	1	1	1	TEE ASS.
25	9090 1519 00		1	1	1	1	1	1	1	1	1	1	1	1	1	1	1	1	1	1	1	1	1	1	1	1	1	1	1	1	1	1	ELBOW UNION
26	0070 7250 04		1	1	1	1	1	1	1	1	1	1	1	1	1	1	1	1	1	1	1	1	1	1	1	1	1	1	1	1	1	1	HOSE (IN METERS)
27	2202 8588 01		1	1	1	1	1	1	1	1	1	1	1	1	1	1	1	1	1	1	1	1	1	1	1	1	1	1	1	1	1	1	AIR-OIL COOLER
28	2202 9753 00		1	1	1			1	1	1				1	1	1																	PIPE AIR

TAB. 8			Q.tà - Qty - Qté - Anz. - Cant. (270 Lit.)																		Rraffreddatore aria-olio / Refroidisseur air/huile / Air-oil cooler / Refroidisseur air/huile / Abscheider Luft-Öl / Refrigerador aire/aceite										
			HP 20 / kW 15 (400/50 Hz - 380-440/60Hz)									HP 20 / kW 15 (230/50 Hz - 230/60Hz)																			
Rif. N. Ref. No Nr. Ref. Bild Nr. Rif. N.	N. ordinaz. Part. num. Nr. Pièce Teil num. Codigo	Note-Note-Nota Anm.-Nota	4152 0252 80	4152 0252 81	4152 0252 82	4152 0252 86	4152 0252 87	4152 0252 88	4152 0253 40	4152 0253 41	4152 0253 42	4152 0253 46	4152 0253 47	4152 0253 48	4152 0252 62	4152 0252 63	4152 0252 64	4152 0252 68	4152 0252 69	4152 0252 70	4152 0253 22	4152 0253 23	4152 0253 24	4152 0253 28	4152 0253 29	4152 0253 30	DESCRIZIONE - DESCRIPTION - DESIGNATION - BESCHREIBUNG - DESIGNACION				
1	2202 9472 16		1	1	1	1	1	1	1	1	1	1	1	1															STIRRUP		
2	0603 4105 03						1	1	1			1	1	1				1	1	1				1	1	1		NIPPLE			
3	8102 8425 34					1	1	1				1	1	1				1	1	1				1	1	1		FILTER ASSEMBLY			
4	2258 2901 14					1	1	1				1	1	1				1	1	1				1	1	1		FILTER ELEMENT			
5	2202 8858 00		2	2	2	2	2	2	2	2	2	2	2	2		2	2	2	2	2	2	2	2	2	2	2	2	2	REDUCTION		
6	0347 6103 00					1	1	1				1	1	1				1	1	1				1	1	1		HOSE CLAMP			
7	0070 6002 49					1	1	1				1	1	1				1	1	1				1	1	1		HOSE (IN METERS)			
8	2202 8858 00		1	1	1	1	1	1	1	1	1	1	1	1		1	1	1	1	1	1	1	1	1	1	1	1	REDUCTION			
9	2202 9482 00		1	1	1	1	1	1	1	1	1	1	1	1		1	1	1	1	1	1	1	1	1	1	1	1	PIPE AIR OUTLET			
10	2202 9481 00		1	1	1	1	1	1	1	1	1	1	1	1		1	1	1	1	1	1	1	1	1	1	1	1	PIPE OIL DELIVERY			
11	2202 9480 01		1	1	1	1	1	1	1	1	1	1	1	1		1	1	1	1	1	1	1	1	1	1	1	1	PIPE OIL RETURN			
12	2202 9754 00		1	1	1				1	1	1					1	1	1					1	1	1			PIPE AIR DRYER (OUT)			
12	2202 9487 01					1	1	1				1	1	1				1	1	1				1	1	1		PIPE AIR DRYER (OUT)			
13	2202 9486 00					1	1	1				1	1	1				1	1	1				1	1	1		PIPE AIR DRYER (IN)			
14	2202 9264 00					1	1	1				1	1	1				1	1	1				1	1	1		ADAPTER			
15	0661 1000 40					2	2	2				2	2	2				2	2	2				2	2	2		SEAL WASHER			
16	2202 8681 07		1	1	1	1	1	1	1	1	1	1	1	1		1	1	1	1	1	1	1	1	1	1	1	1	FLEXIBLE TUBE			
17	2202 9458 00		1	1	1				1	1	1					1	1	1					1	1	1			TEE ASS.			
17	2202 9458 80					1	1	1				1	1	1				1	1	1				1	1	1		TEE ASS.			
25	9090 1519 00		1	1	1	1	1	1	1	1	1	1	1	1		1	1	1	1	1	1	1	1	1	1	1	1	ELBOW UNION			
26	0070 7250 04		1	1	1	1	1	1	1	1	1	1	1	1		1	1	1	1	1	1	1	1	1	1	1	1	HOSE (IN METERS)			
27	2202 8589 01		1	1	1	1	1	1	1	1	1	1	1	1		1	1	1	1	1	1	1	1	1	1	1	1	AIR-OIL COOLER			
28	2202 9753 00		1	1	1				1	1	1					1	1	1					1	1	1			PIPE AIR			











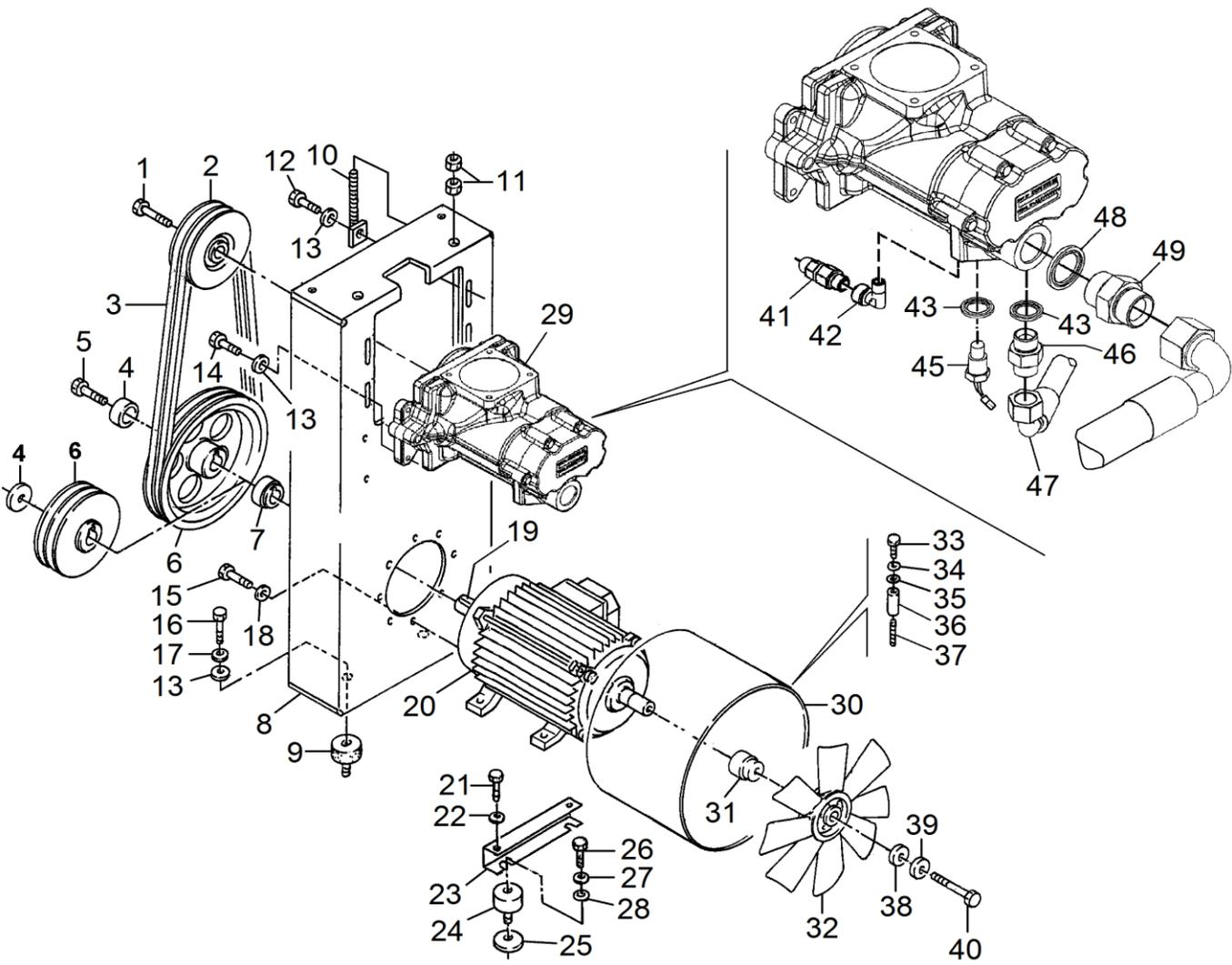























**TAB. 9**

**Staffa porta motore elettrico compressore a vite - Trasmissione / Screw compressor and electric motor metal support-Transmission / Étrier supporte moteur électrique compresseur a vis -  
Transmission / Schraubenkompressor-und Eletromotorstütze Riementrieb / Estribo soporte motor eléctrico compresor de tornillo - Transmisión por correa**

Q.tà - Qty - Qté - Anz. - Cant.

HP 15 / kW 11 (230/60 Hz - 380-440/60Hz)

DESCRIZIONE - DESCRIPTION - DESIGNATION - BESCHREIBUNG -  
DESIGNACION

Rif. N. Ref. No Nr. Réf. Bild Nr. Rif. N.	N. ordinaz. Part. num. Nr. Pièce Teil num. Codigo	Note-Note-Note- Ann.-Nota	4152 0252 13	4152 0252 14	4152 0252 15	4152 0252 21	4152 0252 22	4152 0252 23	4152 0252 29	4152 0252 30	4152 0252 31	4152 0252 45	4152 0252 46	4152 0252 47	4152 0252 37	4152 0252 38	4152 0252 39	4152 0252 33	4152 0252 54	4152 0252 55		4152 0251 65	4152 0251 66	4152 0251 67	4152 0251 73	4152 0251 74	4152 0251 75	4152 0251 81	4152 0251 82	4152 0251 83	4152 0251 97	4152 0251 98	4152 0251 99	4152 0251 89	4152 0251 90	4152 0251 91	4152 0252 05	4152 0252 06	4152 0252 07	
42	1503 2565 01		1	1	1	1	1	1	1	1	1	1	1	1	1	1	1	1	1	1	1	1	1	1	1	1	1	1	1	1	1	1	1	1	1	1	1	1	1	1
43	0661 1000 39		2	2	2	2	2	2	2	2	2	2	2	2	2	2	2	2	2	2	2	2	2	2	2	2	2	2	2	2	2	2	2	2	2	2	2	2	2	2
45	2204 1417 00		1	1	1	1	1	1	1	1	1	1	1	1	1	1	1	1	1	1	1	1	1	1	1	1	1	1	1	1	1	1	1	1	1	1	1	1	1	1
46	0571 0035 76		1	1	1	1	1	1	1	1	1	1	1	1	1	1	1	1	1	1	1	1	1	1	1	1	1	1	1	1	1	1	1	1	1	1	1	1	1	1
47	2202 7050 07		1	1	1	1	1	1	1	1	1	1	1	1	1	1	1	1	1	1	1	1	1	1	1	1	1	1	1	1	1	1	1	1	1	1	1	1	1	1
48	0661 1000 44		1	1	1	1	1	1	1	1	1	1	1	1	1	1	1	1	1	1	1	1	1	1	1	1	1	1	1	1	1	1	1	1	1	1	1	1	1	1
49	0571 0035 77		1	1	1	1	1	1	1	1	1	1	1	1	1	1	1	1	1	1	1	1	1	1	1	1	1	1	1	1	1	1	1	1	1	1	1	1	1	1
	3001 5334 49		1	1	1	1	1	1	1	1	1	1	1	1	1	1	1	1	1	1	1	1	1	1	1	1	1	1	1	1	1	1	1	1	1	1	1	1	1	1
	2901 3500 00		1	1	1	1	1	1	1	1	1	1	1	1	1	1	1	1	1	1	1	1	1	1	1	1	1	1	1	1	1	1	1	1	1	1	1	1	1	1

ELBOW COUPLING  
SEAL WASHER  
SENSOR TEMPERATURE  
NIPPLE  
FLEXIBLE TUBE  
SEAL WASHER  
NIPPLE  
ELEMENT OVERHAUL KIT  
SHAFT SEAL KIT



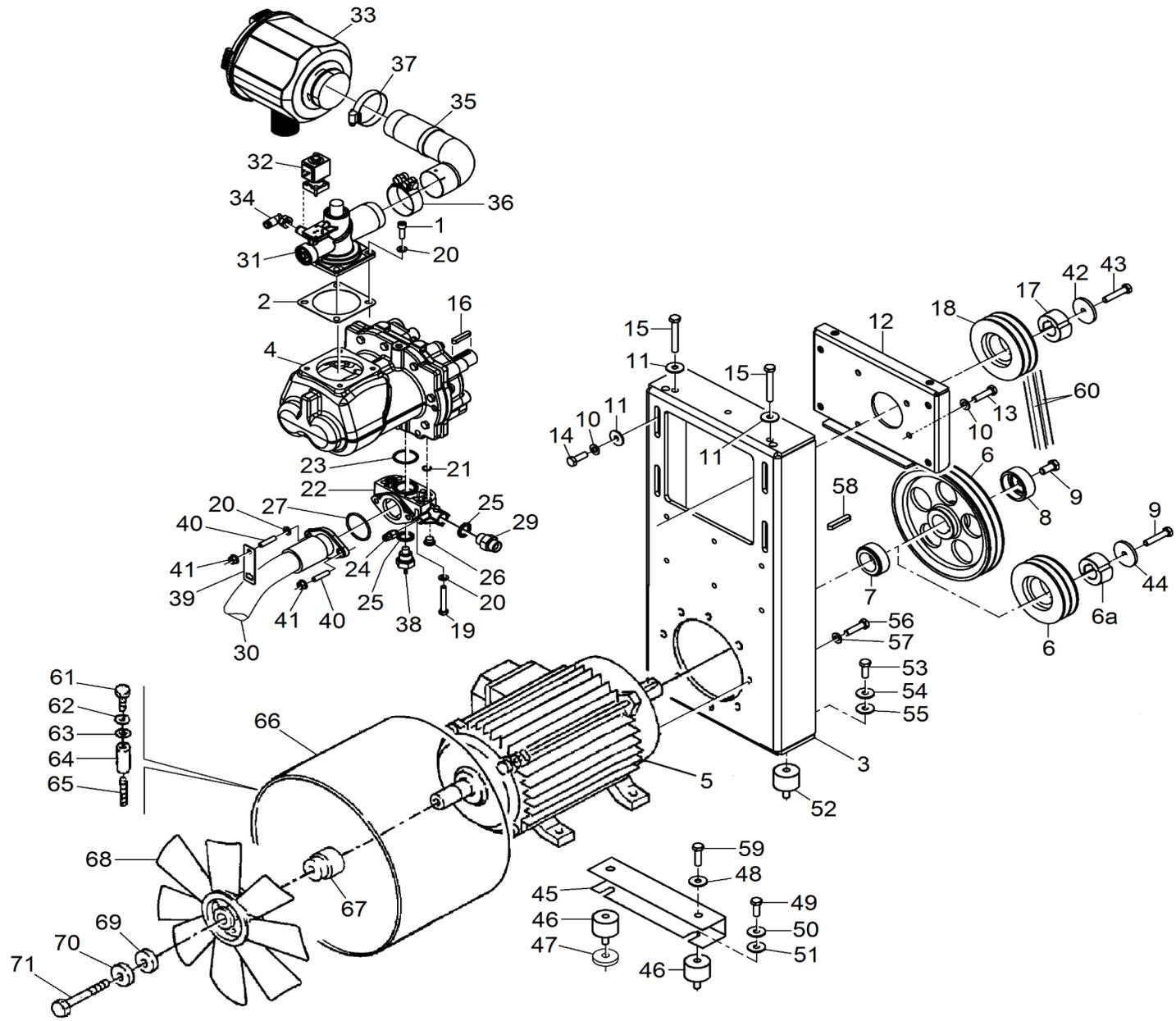











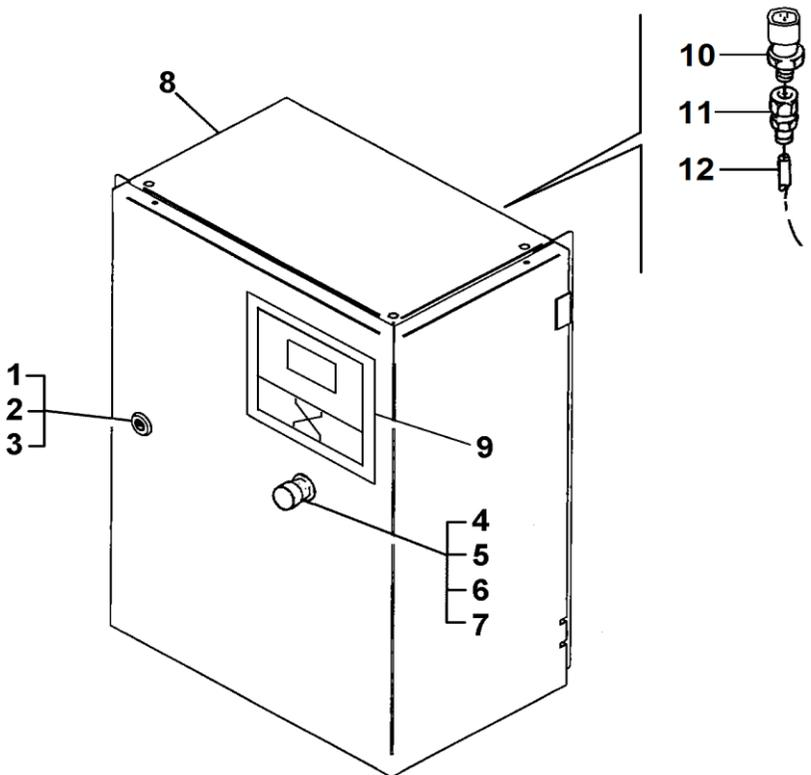

**TAB. 11**

**Pannello comandi e quadro elettrico Electric board control panel Panneau de commandes tableau électrique Elektrische schalttafel Panel de mandos y tablero eléctrico**

Q.tà - Qty - Q.té - Anz. - Cant.

HP 7,5 / kW 5,5 (230/50Hz - 400/50 Hz - 230/60Hz - 380-440/60Hz)

Rif. N. Ref. No Nr. Rêf. Bild Nr. Rif. N.	N. ordinaz. Part. num. Nr. Pièce Teil num. Codigo	Note-Note- Anm.-Nota	4152 0250 64	4152 0250 65	4152 0250 80	4152 0250 81	4152 0250 16	4152 0250 17	4152 0250 32	4152 0250 33	4152 0252 24	4152 0252 25	4152 0252 40	4152 0252 41	4152 0251 76	4152 0251 77	4152 0251 92	4152 0251 93	4152 0250 72	4152 0250 73	4152 0250 88	4152 0250 89	4152 0250 24	4152 0250 25	4152 0250 40	4152 0250 41	4152 0251 12	4152 0251 13	4152 0251 20	4152 0251 21					DESCRIZIONE - DESCRIPTION - DESIGNATION - BESCHREIBUNG - DESIGNACION			
1	2200 5402 64		1	1	1	1	1	1	1	1	1	1	1	1	1	1	1	1	1	1	1	1	1	1	1	1	1	1	1	1	1	1	1	1	1	KEY		
2	2202 2512 59		1	1	1	1	1	1	1	1	1	1	1	1	1	1	1	1	1	1	1	1	1	1	1	1	1	1	1	1	1	1	1	1	1	DRAW LATCH		
3	2200 5402 76		1	1	1	1	1	1	1	1	1	1	1	1	1	1	1	1	1	1	1	1	1	1	1	1	1	1	1	1	1	1	1	1	1	DOOR LOCK		
4	1089 9513 34		1	1	1	1	1	1	1	1	1	1	1	1	1	1	1	1	1	1	1	1	1	1	1	1	1	1	1	1	1	1	1	1	1	EMERGENCY STOP		
5	1089 9513 30		2	2	2	2	2	2	2	2	2	2	2	2	2	2	2	2	2	2	2	2	2	2	2	2	2	2	2	2	2	2	2	2	2	NC CONTACT		
6	1089 9513 28		1	1	1	1	1	1	1	1	1	1	1	1	1	1	1	1	1	1	1	1	1	1	1	1	1	1	1	1	1	1	1	1	1	BUTTON SUPPORT		
7	1089 9125 13		1	1	1	1	1	1	1	1	1	1	1	1	1	1	1	1	1	1	1	1	1	1	1	1	1	1	1	1	1	1	1	1	1	YELLOW RING		
8	2205 0135 51		1	1															1	1															1	CUBICLE		
8	2205 0135 55				1	1															1	1													1	CUBICLE		
8	2205 0135 21						1	1							1	1							1	1												CUBICLE		
8	2205 0135 23								1	1							1	1							1	1											CUBICLE	
8	2205 0135 81										1	1																									CUBICLE	
8	2205 0135 83												1	1																							CUBICLE	
9	1900 5200 77		1	1	1	1	1	1	1	1	1	1	1	1	1	1	1	1	1	1	1	1	1	1	1	1	1	1	1	1	1	1	1	1	1	1	ELEKTRONIKON STD ES4000	
10	2204 1039 00		1	1	1	1	1	1	1	1	1	1	1	1	1	1	1	1	1	1	1	1	1	1	1	1	1	1	1	1	1	1	1	1	1	1	PRESSURE TRANSMITTER	
11	2204 1407 00		1	1	1	1	1	1	1	1	1	1	1	1	1	1	1	1	1	1	1	1	1	1	1	1	1	1	1	1	1	1	1	1	1	1	1	STRAIGHT FEMALE FITTING
12	0070 7250 04		X	X	X	X	X	X	X	X	X	X	X	X	X	X	X	X	X	X	X	X	X	X	X	X	X	X	X	X	X	X	X	X	X	X	HOSE (IN METERS)	



# TAB. 11

Pannello comandi e quadro elettrico Electric board control panel Panneau de commandes tableau électrique Elektrische schalttafel Panel de mandos y tablero eléctrico

Q.tà - Qty - Q.té - Anz. - Cant.

HP 10 / kW 7,5 (230/50Hz - 400/50 Hz - 230/60Hz - 380-440/60Hz)

DESCRIZIONE - DESCRIPTION - DESIGNATION -  
BESCHREIBUNG - DESIGNACION

Rif. N. Ref. No Nr. Rêf. Bild Nr. Rif. N.	N. ordinaz. Part. num. Nr. Pièce Teil num. Codigo	Note-Note-Note- Anm.-Nota	4152 0250 66	4152 0250 67	4152 0250 68	4152 0250 82	4152 0250 83	4152 0250 84	4152 0250 18	4152 0250 19	4152 0250 20	4152 0250 34	4152 0250 35	4152 0250 36	4152 0252 26	4152 0252 27	4152 0252 28	4152 0252 42	4152 0252 43	4152 0252 44	4152 0251 78	4152 0251 79	4152 0251 80	4152 0251 94	4152 0251 95	4152 0251 96	4152 0250 74	4152 0250 75	4152 0250 76	4152 0250 90	4152 0250 91	4152 0250 92	4152 0250 26	4152 0250 27	4152 0250 28	4152 0250 42	4152 0250 43	4152 0250 44	4152 0251 14	4152 0251 15	4152 0251 16	4152 0251 22	4152 0251 23	4152 0251 24			
1	2200 5402 64		1	1	1	1	1	1	1	1	1	1	1	1	1	1	1	1	1	1	1	1	1	1	1	1	1	1	1	1	1	1	1	1	1	1	1	1	1	1	1	1	1	1			
2	2202 2512 59		1	1	1	1	1	1	1	1	1	1	1	1	1	1	1	1	1	1	1	1	1	1	1	1	1	1	1	1	1	1	1	1	1	1	1	1	1	1	1	1	1	1			
3	2200 5402 76		1	1	1	1	1	1	1	1	1	1	1	1	1	1	1	1	1	1	1	1	1	1	1	1	1	1	1	1	1	1	1	1	1	1	1	1	1	1	1	1	1	1			
4	1089 9513 34		1	1	1	1	1	1	1	1	1	1	1	1	1	1	1	1	1	1	1	1	1	1	1	1	1	1	1	1	1	1	1	1	1	1	1	1	1	1	1	1	1	1			
5	1089 9513 30		2	2	2	2	2	2	2	2	2	2	2	2	2	2	2	2	2	2	2	2	2	2	2	2	2	2	2	2	2	2	2	2	2	2	2	2	2	2	2	2	2	2			
6	1089 9513 28		1	1	1	1	1	1	1	1	1	1	1	1	1	1	1	1	1	1	1	1	1	1	1	1	1	1	1	1	1	1	1	1	1	1	1	1	1	1	1	1	1	1			
7	1089 9125 13		1	1	1	1	1	1	1	1	1	1	1	1	1	1	1	1	1	1	1	1	1	1	1	1	1	1	1	1	1	1	1	1	1	1	1	1	1	1	1	1	1	1			
8	2205 0135 52		1	1	1																							1	1	1											1	1	1				
8	2205 0135 56					1	1	1																									1	1	1												
8	2205 0135 21							1	1	1												1	1	1																							
8	2205 0135 23										1	1	1											1	1	1																					
8	2205 0135 81												1	1	1																																
8	2205 0135 83															1	1	1																													
9	1900 5200 77		1	1	1	1	1	1	1	1	1	1	1	1	1	1	1	1	1	1	1	1	1	1	1	1	1	1	1	1	1	1	1	1	1	1	1	1	1	1	1	1	1	1	1		
10	2204 1039 00		1	1	1	1	1	1	1	1	1	1	1	1	1	1	1	1	1	1	1	1	1	1	1	1	1	1	1	1	1	1	1	1	1	1	1	1	1	1	1	1	1	1	1		
11	2204 1407 00		1	1	1	1	1	1	1	1	1	1	1	1	1	1	1	1	1	1	1	1	1	1	1	1	1	1	1	1	1	1	1	1	1	1	1	1	1	1	1	1	1	1	1	1	
12	0070 7250 04		X	X	X	X	X	X	X	X	X	X	X	X	X	X	X	X	X	X	X	X	X	X	X	X	X	X	X	X	X	X	X	X	X	X	X	X	X	X	X	X	X	X	X	X	







# TAB. 11

Pannello comandi e quadro elettrico Electric board control panel Panneau de commandes tableau électrique Elektrische schalttafel Panel de mandos y tablero eléctrico

Q.tà - Qty - Q.té - Anz. - Cant.

HP 20 / kW 15 (230/50Hz - 400/50 Hz - 230/60Hz - 380-440/60Hz)

DESCRIZIONE - DESCRIPTION - DESIGNATION -  
BESCHREIBUNG - DESIGNACION

Rif. N. Ref. No Nr. Rêf. Bild Nr. Rif. N.	N. ordinaz. Part. num. Nr. Pièce Teil num. Codigo	Note-Note-Note- Anm.-Nota	4152 0252 80	4152 0252 81	4152 0252 82	4152 0252 86	4152 0252 87	4152 0252 88	4152 0252 62	4152 0252 63	4152 0252 64	4152 0252 68	4152 0252 69	4152 0252 70	4152 0253 22	4152 0253 23	4152 0253 24	4152 0253 28	4152 0253 29	4152 0253 30	4152 0253 40	4152 0253 41	4152 0253 42	4152 0253 46	4152 0253 47	4152 0253 48	4152 0252 83	4152 0252 84	4152 0252 85	4152 0252 98	4152 0252 99	4152 0253 00	4152 0252 89	4152 0252 90	4152 0252 91	4152 0253 01	4152 0253 02	4152 0253 03	4152 0252 65	4152 0252 66	4152 0252 67	4152 0252 71	4152 0252 72	4152 0252 73							
1	2200 5402 64		1	1	1	1	1	1	1	1	1	1	1	1	1	1	1	1	1	1	1	1	1	1	1	1	1	1	1	1	1	1	1	1	1	1	1	1	1	1	1	1	1	1	1	1	1	KEY			
2	2202 2512 59		1	1	1	1	1	1	1	1	1	1	1	1	1	1	1	1	1	1	1	1	1	1	1	1	1	1	1	1	1	1	1	1	1	1	1	1	1	1	1	1	1	1	1	1	1	1	DRAW LATCH		
3	2200 5402 76		1	1	1	1	1	1	1	1	1	1	1	1	1	1	1	1	1	1	1	1	1	1	1	1	1	1	1	1	1	1	1	1	1	1	1	1	1	1	1	1	1	1	1	1	1	1	1	DOOR LOCK	
4	1089 9513 34		1	1	1	1	1	1	1	1	1	1	1	1	1	1	1	1	1	1	1	1	1	1	1	1	1	1	1	1	1	1	1	1	1	1	1	1	1	1	1	1	1	1	1	1	1	1	1	EMERGENCY STOP	
5	1089 9513 30		2	2	2	2	2	2	2	2	2	2	2	2	2	2	2	2	2	2	2	2	2	2	2	2	2	2	2	2	2	2	2	2	2	2	2	2	2	2	2	2	2	2	2	2	2	2	2	NC CONTACT	
6	1089 9513 28		1	1	1	1	1	1	1	1	1	1	1	1	1	1	1	1	1	1	1	1	1	1	1	1	1	1	1	1	1	1	1	1	1	1	1	1	1	1	1	1	1	1	1	1	1	1	1	BUTTON SUPPORT	
7	1089 9125 13		1	1	1	1	1	1	1	1	1	1	1	1	1	1	1	1	1	1	1	1	1	1	1	1	1	1	1	1	1	1	1	1	1	1	1	1	1	1	1	1	1	1	1	1	1	1	1	YELLOW RING	
8	2205 0135 54		1	1	1																																													CUBICLE	
8	2205 0135 58					1	1	1																																										CUBICLE	
8	2205 0135 22								1	1	1				1	1	1																																		CUBICLE
8	2205 0135 24											1	1	1			1	1	1																																CUBICLE
8	2205 0135 82																			1	1	1																													CUBICLE
8	2205 0135 84																				1	1	1																											CUBICLE	
9	1900 5200 77		1	1	1	1	1	1	1	1	1	1	1	1	1	1	1	1	1	1	1	1	1	1	1	1	1	1	1	1	1	1	1	1	1	1	1	1	1	1	1	1	1	1	1	1	1	1	1	ELEKTRONIKON STD ES4000	
10	2204 1039 00		1	1	1	1	1	1	1	1	1	1	1	1	1	1	1	1	1	1	1	1	1	1	1	1	1	1	1	1	1	1	1	1	1	1	1	1	1	1	1	1	1	1	1	1	1	1	1	PRESSURE TRANSMITTER	
11	2204 1407 00		1	1	1	1	1	1	1	1	1	1	1	1	1	1	1	1	1	1	1	1	1	1	1	1	1	1	1	1	1	1	1	1	1	1	1	1	1	1	1	1	1	1	1	1	1	1	1	STRAIGHT FEMALE FITTING	
12	0070 7250 04		X	X	X	X	X	X	X	X	X	X	X	X	X	X	X	X	X	X	X	X	X	X	X	X	X	X	X	X	X	X	X	X	X	X	X	X	X	X	X	X	X	X	X	X	X	X	HOSE (IN METERS)		





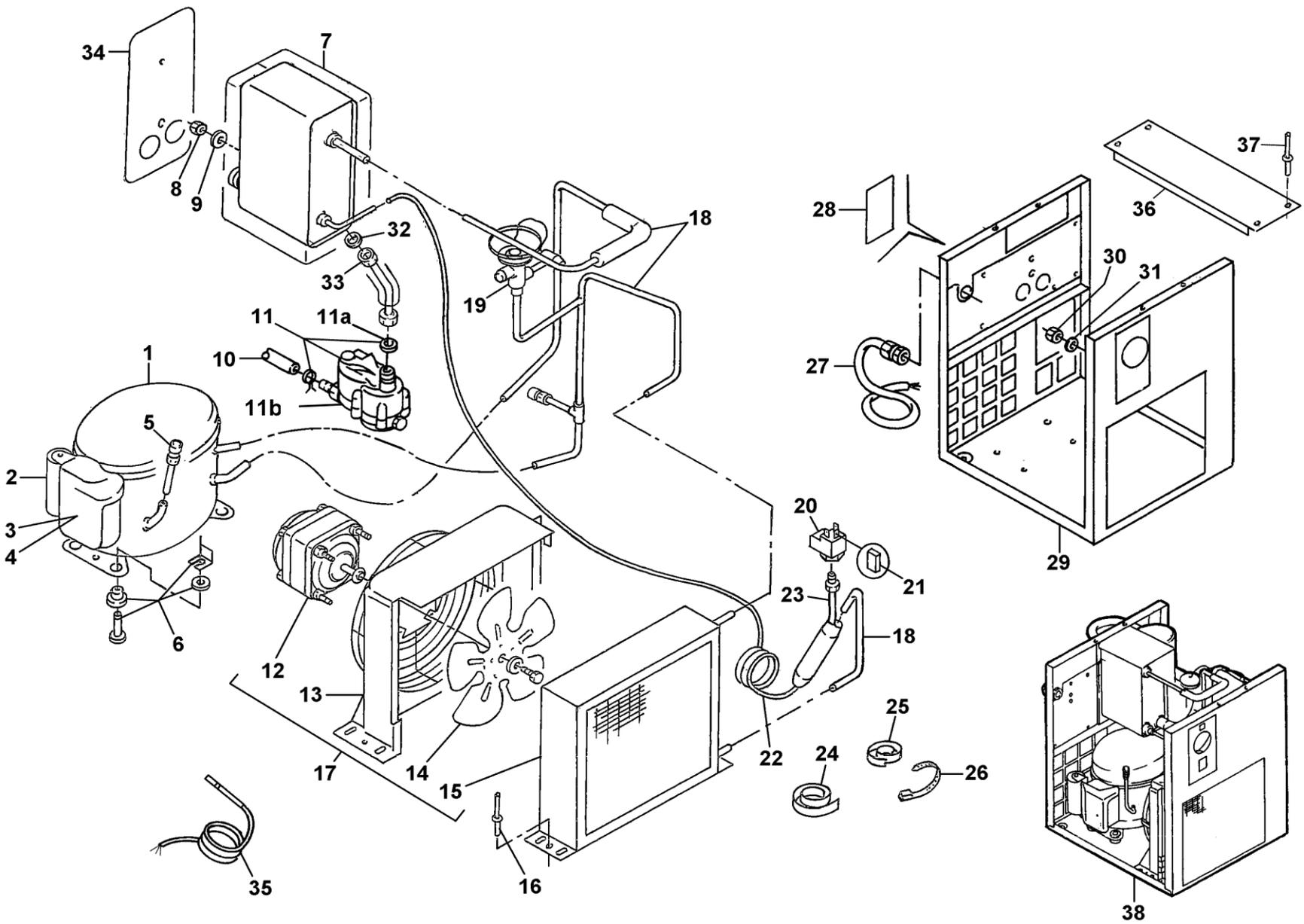

Table with 38 rows and multiple columns. Columns include: Rif. N., N. ordinaz., Note-Note-Ann., HP 7,5 / kW 5,5 (400/50 Hz), HP 7,5 / kW 5,5 (230/50 Hz), HP 10 / kW 7,5 (400/50 Hz), HP 10 / kW 7,5 (230/50 Hz), and DESCRIZIONE - DESCRIPTION - DESIGNATION - BESCHREIBUNG - DESIGNACION. Row 1: 1624 9123 17, COMPRESSOR. Row 38: 2200 9029 51, DRYER V.230/50.

TAB. 12

Essiccatore d'aria / Air dryer / Secheur d'air / Lufttrockner / Secador de aire

Q.tà - Qty - Q.té - Anz. - Cant.

HP 7,5 / kW 5,5 (400/50 Hz) HP 7,5 / kW 5,5 (230/50 Hz) HP 10 / kW 7,5 (400/50 Hz) HP 10 / kW 7,5 (230/50 Hz)

DESCRIZIONE - DESCRIPTION - DESIGNATION - BESCHREIBUNG - DESIGNACION

Rif. N. Ref. No. Nr. Réf. Bild Nr. Rif. N. N. ordinaz. Part. num. Nr. Pièce Teil num. Codigo

4152 0250 56 4152 0250 57 4152 0250 80 4152 0250 81 4152 0250 88 4152 0250 89 4152 0251 20 4152 0251 21 4152 0251 52 4152 0251 53 4152 0250 08 4152 0250 09 4152 0250 32 4152 0250 33 4152 0250 40 4152 0250 41 4152 0250 58 4152 0250 59 4152 0250 60 4152 0250 82 4152 0250 83 4152 0250 84 4152 0250 90 4152 0250 91 4152 0250 92 4152 0251 22 4152 0251 23 4152 0251 24 4152 0251 54 4152 0251 55 4152 0251 56 4152 0250 10 4152 0250 11 4152 0250 12 4152 0250 34 4152 0250 35 4152 0250 36 4152 0250 42 4152 0250 44

Main data table with 38 rows corresponding to components. Each row contains a grid of '1' and 'X' characters aligned with the headers in the previous block. Row 1: 1 1624 9123 17. Row 2: 2 1617 1549 22. Row 3: 3 1617 1551 69. Row 4: 4 1617 1550 77. Row 5: 5 2200 5997 43. Row 6: 6 2200 9026 81. Row 7: 7 2202 8922 84. Row 8: 8 0291 1128 15. Row 9: 9 0300 0274 64. Row 10: 10 0070 6002 49. Row 11: 11 2202 7547 01. Row 11a: 0663 9096 00. Row 11b: 2200 9020 17. Row 12: 2202 7622 01. Row 13: 2202 7621 03. Row 14: 2202 7623 02. Row 15: 2202 7620 03. Row 16: 0129 3270 42. Row 17: 2202 7512 81. Row 18: 2202 9091 81. Row 19: 2202 7324 04. Row 20: 2200 6006 78. Row 21: 2200 7099 06. Row 22: 2202 7584 04. Row 23: 2202 7569 04. Row 24: 2202 7587 01. Row 25: 0017 9862 67. Row 26: 0348 0101 20. Row 27: 2205 0221 01. Row 28: 1079 9926 55. Row 29: 2202 9758 81. Row 30: 0266 2108 00. Row 31: 0333 4220 00. Row 32: 2202 8924 00. Row 33: 2202 8895 01. Row 34: 2202 8930 00. Row 35: 2202 8870 02. Row 36: 2202 7662 00. Row 37: 0129 3270 40. Row 38: 2200 9029 51.



# TAB. 12

Essiccatore d'aria / Air dryer / Secheur d'air / Lufttrockner / Secador de aire

Q.tà - Qty - Q.té - Anz. - Cant.

HP 7,5 / kW 5,5 (230/60 Hz - 380-440/60Hz)

HP 10 / kW 7,5 (230/60 Hz - 380-440/60Hz)

DESCRIZIONE - DESCRIPTION - DESIGNATION - BESCHREIBUNG -  
DESIGNACION

Rif. N. Ref. No Nr. Réf. Bild Nr. Rif. N.	N. ordinaz. Part. num. Nr. Pièce Teil num. Codigo	Nota-Note-Note- Ann.-Nota	4152 0252 16	4152 0252 17	4152 0252 40	4152 0252 41	4152 0252 48	4152 0252 49			4152 0251 68	4152 0251 69	4152 0251 92	4152 0251 93	4152 0252 00	4152 0252 01				4152 0252 18	4152 0252 19	4152 0252 20	4152 0252 42	4152 0252 43	4152 0252 44	4152 0252 50	4152 0252 51	4152 0252 52			4152 0251 70	4152 0251 71	4152 0251 72	4152 0251 94	4152 0251 95	4152 0251 96	4152 0252 02	4152 0252 03	4152 0252 04									
1	1624 9123 15		1	1	1	1	1	1			1	1	1	1	1	1	1	1	1	1	1	1	1	1	1	1	1	1	1	1	1	1	1	1	1	1	1	1	1	1	1	1	1	1	COMPRESSOR			
2	1617 1549 21		1	1	1	1	1	1			1	1	1	1	1	1	1	1	1	1	1	1	1	1	1	1	1	1	1	1	1	1	1	1	1	1	1	1	1	1	1	1	1	1	1	START CAPACITOR		
3	1617 1551 66		1	1	1	1	1	1			1	1	1	1	1	1	1	1	1	1	1	1	1	1	1	1	1	1	1	1	1	1	1	1	1	1	1	1	1	1	1	1	1	1	1	1	START RELAY	
4	1617 1550 79		1	1	1	1	1	1			1	1	1	1	1	1	1	1	1	1	1	1	1	1	1	1	1	1	1	1	1	1	1	1	1	1	1	1	1	1	1	1	1	1	1	1	OVERLOAD PROTECTOR	
5	2200 5997 43		1	1	1	1	1	1			1	1	1	1	1	1	1	1	1	1	1	1	1	1	1	1	1	1	1	1	1	1	1	1	1	1	1	1	1	1	1	1	1	1	1	1	CHECK VALVE	
6	2200 9026 81		1	1	1	1	1	1			1	1	1	1	1	1	1	1	1	1	1	1	1	1	1	1	1	1	1	1	1	1	1	1	1	1	1	1	1	1	1	1	1	1	1	1	SNUP-ON	
7	2202 8922 84		1	1	1	1	1	1			1	1	1	1	1	1	1	1	1	1	1	1	1	1	1	1	1	1	1	1	1	1	1	1	1	1	1	1	1	1	1	1	1	1	1	1	EXCHANGER	
8	0291 1128 15		2	2	2	2	2	2			2	2	2	2	2	2	2	2	2	2	2	2	2	2	2	2	2	2	2	2	2	2	2	2	2	2	2	2	2	2	2	2	2	2	2	2	NUT	
9	0300 0274 64		2	2	2	2	2	2			2	2	2	2	2	2	2	2	2	2	2	2	2	2	2	2	2	2	2	2	2	2	2	2	2	2	2	2	2	2	2	2	2	2	2	2	WASHER	
10	0070 6002 49		X	X	X	X	X	X			X	X	X	X	X	X	X	X	X	X	X	X	X	X	X	X	X	X	X	X	X	X	X	X	X	X	X	X	X	X	X	X	X	X	X	HOSE (IN METERS)		
11	2202 7547 01		1	1	1	1	1	1			1	1	1	1	1	1	1	1	1	1	1	1	1	1	1	1	1	1	1	1	1	1	1	1	1	1	1	1	1	1	1	1	1	1	1	CONDENSATE DRAIN		
11a	0663 9096 00		1	1	1	1	1	1			1	1	1	1	1	1	1	1	1	1	1	1	1	1	1	1	1	1	1	1	1	1	1	1	1	1	1	1	1	1	1	1	1	1	1	O-RING		
11b	2200 9020 17		1	1	1	1	1	1			1	1	1	1	1	1	1	1	1	1	1	1	1	1	1	1	1	1	1	1	1	1	1	1	1	1	1	1	1	1	1	1	1	1	1	1	KIT CONDENSATE DRAIN	
12	2202 7622 02		1	1	1	1	1	1			1	1	1	1	1	1	1	1	1	1	1	1	1	1	1	1	1	1	1	1	1	1	1	1	1	1	1	1	1	1	1	1	1	1	1	1	FAN MOTOR	
13	2202 7621 03		1	1	1	1	1	1			1	1	1	1	1	1	1	1	1	1	1	1	1	1	1	1	1	1	1	1	1	1	1	1	1	1	1	1	1	1	1	1	1	1	1	1	PROTECTION	
14	2202 7623 02		1	1	1	1	1	1			1	1	1	1	1	1	1	1	1	1	1	1	1	1	1	1	1	1	1	1	1	1	1	1	1	1	1	1	1	1	1	1	1	1	1	1	1	FAN
15	2202 7620 03		1	1	1	1	1	1			1	1	1	1	1	1	1	1	1	1	1	1	1	1	1	1	1	1	1	1	1	1	1	1	1	1	1	1	1	1	1	1	1	1	1	1	1	CONDENSER
16	0129 3270 42		2	2	2	2	2	2			2	2	2	2	2	2	2	2	2	2	2	2	2	2	2	2	2	2	2	2	2	2	2	2	2	2	2	2	2	2	2	2	2	2	2	2	2	BLIND RIVET
17	2202 7512 82		1	1	1	1	1	1			1	1	1	1	1	1	1	1	1	1	1	1	1	1	1	1	1	1	1	1	1	1	1	1	1	1	1	1	1	1	1	1	1	1	1	1	CONDENSER UNIT	
18	2202 9091 81		1	1	1	1	1	1			1	1	1	1	1	1	1	1	1	1	1	1	1	1	1	1	1	1	1	1	1	1	1	1	1	1	1	1	1	1	1	1	1	1	1	1	1	PIPE ASS.
19	2202 7324 04		1	1	1	1	1	1			1	1	1	1	1	1	1	1	1	1	1	1	1	1	1	1	1	1	1	1	1	1	1	1	1	1	1	1	1	1	1	1	1	1	1	1	1	BY-PASS VALVE
20	2200 6006 78		1	1	1	1	1	1			1	1	1	1	1	1	1	1	1	1	1	1	1	1	1	1	1	1	1	1	1	1	1	1	1	1	1	1	1	1	1	1	1	1	1	1	1	PRESSOSTAT
21	2200 7099 06		1	1	1	1	1	1			1	1	1	1	1	1	1	1	1	1	1	1	1	1	1	1	1	1	1	1	1	1	1	1	1	1	1	1	1	1	1	1	1	1	1	1	1	CAP PROTECTION
22	2202 7584 04		1	1	1	1	1	1			1	1	1	1	1	1	1	1	1	1	1	1	1	1	1	1	1	1	1	1	1	1	1	1	1	1	1	1	1	1	1	1	1	1	1	1	1	CAPILLARY TUBE
23	2202 7569 04		1	1	1	1	1	1			1	1	1	1	1	1	1	1	1	1	1	1	1	1	1	1	1	1	1	1	1	1	1	1	1	1	1	1	1	1	1	1	1	1	1	1	1	FILTER-DRYER
24	2202 7587 01		1	1	1	1	1	1			1	1	1	1	1	1	1	1	1	1	1	1	1	1	1	1	1	1	1	1	1	1	1	1	1	1	1	1	1	1	1	1	1	1	1	1	1	TAPE (IN METERS)
25	0017 9862 67		1	1	1	1	1	1			1	1	1	1	1	1	1	1	1	1	1	1	1	1	1	1	1	1	1	1	1	1	1	1	1	1	1	1	1	1	1	1	1	1	1	1	1	TAPE (IN METERS)
26	0348 0101 20		9	9	9	9	9	9			9	9	9	9	9	9	9	9	9	9	9	9	9	9	9	9	9	9	9	9	9	9	9	9	9	9	9	9	9	9	9	9	9	9	9	9	9	CABLE TIE
27	2205 0221 01		1	1	1	1	1	1			1	1	1	1	1	1	1	1	1	1	1	1	1	1	1	1	1	1	1	1	1	1	1	1	1	1	1	1	1	1	1	1	1	1	1	1	1	ELECTRIC CABLES
28	1079 9926 55		1	1	1	1	1	1			1	1	1	1	1	1	1	1	1	1	1	1	1	1	1	1	1	1	1	1	1	1	1	1	1	1	1	1	1	1	1	1	1	1	1	1	LABEL	
29	2202 9758 81		1	1	1	1	1	1			1	1	1	1	1	1	1	1	1	1	1	1	1	1	1	1	1	1	1	1	1	1	1	1	1	1	1	1	1	1	1	1	1	1	1	1	PANEL BASE	
30	0266 2108 00		1	1	1	1	1	1			1	1	1	1	1	1	1	1	1	1	1	1	1	1	1	1	1	1	1	1	1	1	1	1	1	1	1	1	1	1	1	1	1	1	1	1	NUT	
31	0333 4220 00		2	2	2	2	2	2			2	2	2	2	2	2	2	2	2	2	2	2	2	2	2	2	2	2	2	2	2	2	2	2	2	2	2	2	2	2	2	2	2	2	2	2	2	WASHER
32	2202 8924 00		1	1	1	1	1	1			1	1	1	1	1	1	1	1	1	1	1	1	1	1	1	1	1	1	1	1	1	1	1	1	1	1	1	1	1	1	1	1	1	1	1	1	1	GASKET
33	2202 8895 01		1	1	1	1	1	1			1	1	1	1	1	1	1	1	1	1	1	1	1	1	1	1	1	1	1	1	1	1	1	1	1	1	1	1	1	1	1	1	1	1	1	1	1	PIPE
34	2202 8930 00		1	1	1	1	1	1			1	1	1	1	1	1	1	1	1	1	1	1	1	1	1	1	1	1	1	1	1	1	1	1	1	1	1	1	1	1	1	1	1	1	1	1	1	INSULATION SET
35	2202 8870 02		1	1																																												





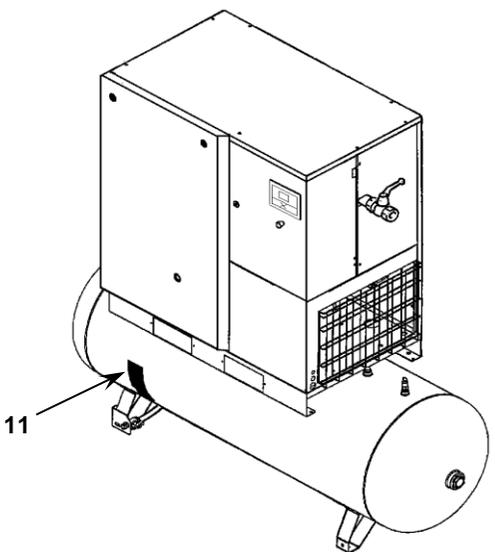
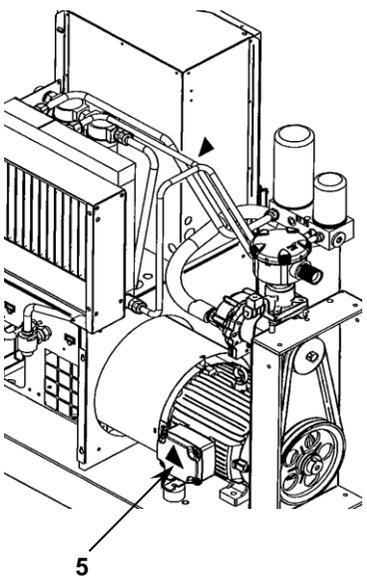
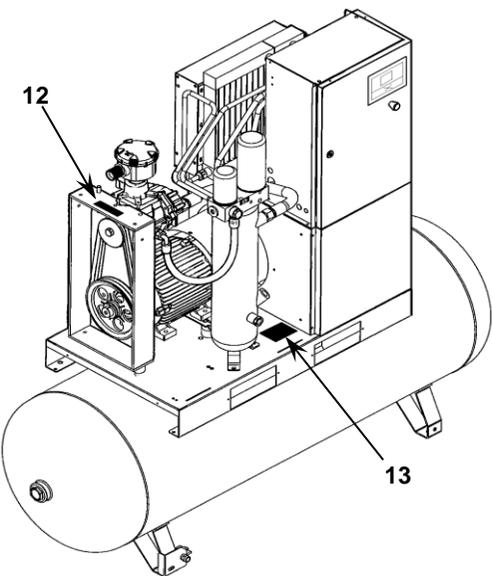
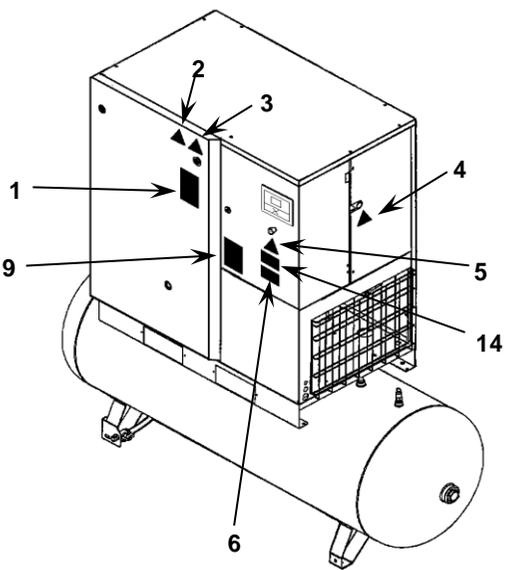
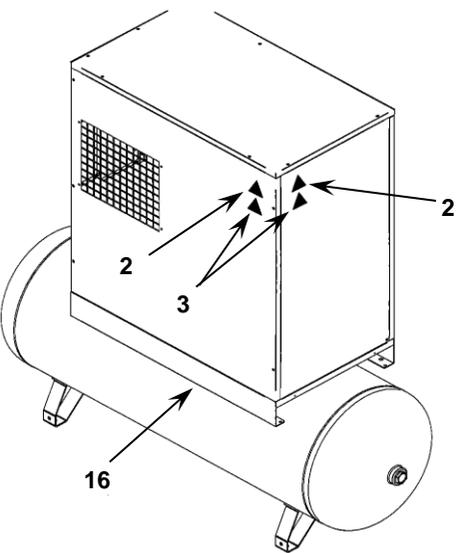
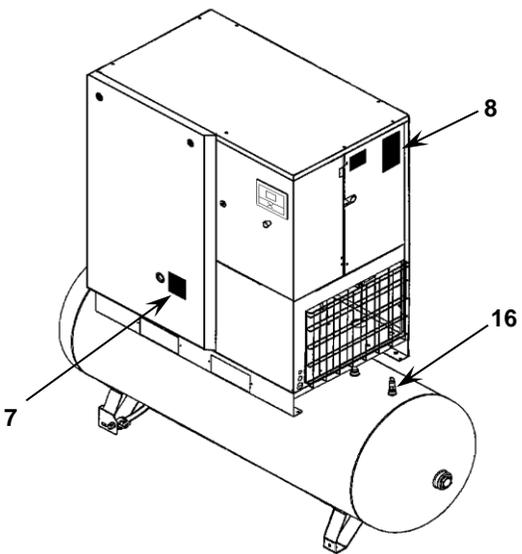

**TAB. 13**

**Targhette / Labels / Plaque / Schild / Placa**

Q.tà - Qty - Q.té - Anz. - Cant.

HP 7,5 / kW 5,5 (230/50Hz - 400/50 Hz - 230/60Hz - 380-440/60Hz)

DESCRIZIONE - DESCRIPTION - DESIGNATION - BESCHREIBUNG - DESIGNACION

Rif. N. Ref. No Nr. Rêf. Bild Nr. Rif. N.	N. ordinaz. Part. num. Nr. Pièce Teil num. Codigo	Note-Note-Note- Anm.-Nota	4152 0250 64	4152 0250 65	4152 0250 80	4152 0250 81	4152 0250 16	4152 0250 17	4152 0250 32	4152 0250 33	4152 0252 24	4152 0252 25	4152 0252 40	4152 0252 41	4152 0251 76	4152 0251 77	4152 0251 92	4152 0251 93	4152 0250 72	4152 0250 73	4152 0250 88	4152 0250 89	4152 0250 24	4152 0250 25	4152 0250 40	4152 0250 41	4152 0251 12	4152 0251 13	4152 0251 20	4152 0251 21	
1	2202 2607 91		4	4	4	4	4	4	4	4	4	4	4	4	4	4	4	4	4	4	4	4	4	4	4	4	4	4	4	4	4
2	2202 2607 91		3	3	3	3	3	3	3	3	3	3	3	3	3	3	3	3	3	3	3	3	3	3	3	3	3	3	3	3	3
3	2202 2607 91		3	3	3	3	3	3	3	3	3	3	3	3	3	3	3	3	3	3	3	3	3	3	3	3	3	3	3	3	3
4	2202 2607 91		1	1	1	1	1	1	1	1	1	1	1	1	1	1	1	1	1	1	1	1	1	1	1	1	1	1	1	1	1
5	1088 1001 02		1	1	1	1	1	1	1	1	1	1	1	1	1	1	1	1	1	1	1	1	1	1	1	1	1	1	1	1	1
6	2202 8731 01			1	1	1	1	1	1	1					1	1	1	1			1	1	1	1	1				1	1	
7	2202 2512 93		1	1	1	1	1	1	1	1	1	1	1	1	1	1	1	1	1	1	1	1	1	1	1	1	1	1	1	1	1
8	2204 1818 13		1	1			1	1			1	1			1	1			1	1			1	1			1	1			
8	2204 1818 03			1	1				1	1			1	1			1	1			1	1			1	1			1	1	
9	2200 2607 91		1	1	1	1	1	1	1	1	1	1	1	1	1	1	1	1	1	1	1	1	1	1	1	1	1	1	1	1	1
11	1079 9931 29		1	1	1	1	1	1	1	1	1	1	1	1	1	1	1	1	1	1	1	1	1	1	1	1	1	1	1	1	1
12	2202 2607 91		1	1	1	1	1	1	1	1	1	1	1	1	1	1	1	1	1	1	1	1	1	1	1	1	1	1	1	1	1
13	2202 2042 89		1	1	1	1	1	1	1	1	1	1	1	1	1	1	1	1	1	1	1	1	1	1	1	1	1	1	1	1	1
14	2202 8731 00			1	1	1	1	1	1						1	1	1	1			1	1	1	1	1				1	1	1

WARNING LABEL
LABEL
LABEL
LABEL
LABEL
LABEL
LABEL 1-PH
LABEL OIL LEVEL
LABEL SERVICE
LABEL SERVICE
LABEL AUTOMATIC START
LABEL PURGE CONDENSATE
LABEL
LABEL
LABEL 3-PH





# TAB. 13

Targhette / Labels / Plaque / Schild / Placa

Q.tà - Qty - Q.té - Anz. - Cant.

HP 10 / kW 7,5 (230/50Hz - 400/50 Hz - 230/60Hz - 380-440/60Hz)

DESCRIZIONE - DESCRIPTION - DESIGNATION -  
BESCHREIBUNG - DESIGNACION

Rif. N. Ref. No Nr. Réf. Bild Nr. Rif. N.	N. ordinaz. Part. num. Nr. Pièce Teil num. Codigo	Note-Note-Note- Anm.-Nota	4152 0251 46	4152 0251 47	4152 0251 48	4152 0251 54	4152 0251 55	4152 0251 56	4152 0251 86	4152 0251 87	4152 0251 88	4152 0252 02	4152 0252 03	4152 0252 04	4152 0252 34	4152 0252 35	4152 0252 36	4152 0252 50	4152 0252 51	4152 0252 52	4152 0250 50	4152 0250 51	4152 0250 52	4152 0250 58	4152 0250 59	4152 0250 60	4152 0250 02	4152 0250 03	4152 0250 04	4152 0250 10	4152 0250 11	4152 0250 12	4152 0251 62	4152 0251 63	4152 0251 64	4152 0251 70	4152 0251 71	4152 0251 72	4152 0252 10	4152 0252 11	4152 0252 12	4152 0252 18	4152 0252 19	4152 0252 20	
1	2202 2607 91		4	4	4	4	4	4	4	4	4	4	4	4	4	4	4	4	4	4	4	4	4	4	4	4	4	4	4	4	4	4	4	4	4	4	4	4	4	4	4	4	4	4	
2	2202 2607 91		3	3	3	3	3	3	3	3	3	3	3	3	3	3	3	3	3	3	3	3	3	3	3	3	3	3	3	3	3	3	3	3	3	3	3	3	3	3	3	3	3	3	
3	2202 2607 91		3	3	3	3	3	3	3	3	3	3	3	3	3	3	3	3	3	3	3	3	3	3	3	3	3	3	3	3	3	3	3	3	3	3	3	3	3	3	3	3	3	3	
4	2202 2607 91		1	1	1	1	1	1	1	1	1	1	1	1	1	1	1	1	1	1	1	1	1	1	1	1	1	1	1	1	1	1	1	1	1	1	1	1	1	1	1	1	1	1	
5	1088 1001 02		1	1	1	1	1	1	1	1	1	1	1	1	1	1	1	1	1	1	1	1	1	1	1	1	1	1	1	1	1	1	1	1	1	1	1	1	1	1	1	1	1	1	
6	2202 8731 01					1	1	1	1	1	1	1	1	1																															
7	2202 2512 93		1	1	1	1	1	1	1	1	1	1	1	1	1	1	1	1	1	1	1	1	1	1	1	1	1	1	1	1	1	1	1	1	1	1	1	1	1	1	1	1	1	1	
8	2204 1818 13		1	1	1				1	1	1				1	1	1											1	1	1															
8	2204 1818 03					1	1	1				1	1	1				1	1	1				1	1	1				1	1	1							1	1	1				
9	2200 2607 91		1	1	1	1	1	1	1	1	1	1	1	1	1	1	1	1	1	1	1	1	1	1	1	1	1	1	1	1	1	1	1	1	1	1	1	1	1	1	1	1	1	1	1
11	1079 9931 29		1	1	1	1	1	1	1	1	1	1	1	1	1	1	1																												
12	2202 2607 91		1	1	1	1	1	1	1	1	1	1	1	1	1	1	1	1	1	1	1	1	1	1	1	1	1	1	1	1	1	1	1	1	1	1	1	1	1	1	1	1	1	1	1
13	2202 2042 89		1	1	1	1	1	1	1	1	1	1	1	1	1	1	1	1	1	1	1	1	1	1	1	1	1	1	1	1	1	1	1	1	1	1	1	1	1	1	1	1	1	1	1
14	2202 8731 00					1	1	1	1	1	1	1	1	1											1	1	1	1	1	1	1	1	1	1	1	1	1	1	1	1	1	1	1	1	1

WARNING LABEL  
 LABEL  
 LABEL  
 LABEL  
 LABEL  
 LABEL 1-PH  
 LABEL OIL LEVEL  
 LABEL SERVICE  
 LABEL SERVICE  
 LABEL AUTOMATIC START  
 LABEL PURGE CONDENSATE  
 LABEL  
 LABEL  
 LABEL 3-PH



TAB. 13

Targhette / Labels / Plaque / Schild / Placa

Q.tà - Qty - Q.té - Anz. - Cant.

HP 15 / kW 11 (230/50Hz - 400/50 Hz - 230/60Hz - 380-440/60Hz)

Rif. N. Ref. No Nr. Rêf. Bild Nr. Rif. N.	N. ordinaz. Part. num. Nr. Pièce Teil num. Codigo	Note-Note-Note- Ann.-Nota	4152 0250 69	4152 0250 70	4152 0250 71	4152 0250 85	4152 0250 86	4152 0250 87	4152 0250 21	4152 0250 22	4152 0250 23	4152 0250 37	4152 0250 38	4152 0250 39	4152 0252 29	4152 0252 30	4152 0252 31	4152 0252 45	4152 0252 46	4152 0252 47	4152 0251 81	4152 0251 82	4152 0251 83	4152 0251 97	4152 0251 98	4152 0251 99	4152 0250 77	4152 0250 78	4152 0250 79	4152 0250 93	4152 0250 94	4152 0250 95	4152 0250 29	4152 0250 30	4152 0250 31	4152 0250 45	4152 0250 46	4152 0250 47	4152 0251 17	4152 0251 18	4152 0251 19	4152 0251 25	4152 0251 26	4152 0251 27		DESCRIZIONE - DESCRIPTION - DESIGNATION - BESCHREIBUNG - DESIGNACION			
1	2202 2607 91		4	4	4	4	4	4	4	4	4	4	4	4	4	4	4	4	4	4	4	4	4	4	4	4	4	4	4	4	4	4	4	4	4	4	4	4	4	4	4	4	4	4	4	4		WARNING LABEL	
2	2202 2607 91		3	3	3	3	3	3	3	3	3	3	3	3	3	3	3	3	3	3	3	3	3	3	3	3	3	3	3	3	3	3	3	3	3	3	3	3	3	3	3	3	3	3	3	3		LABEL	
3	2202 2607 91		3	3	3	3	3	3	3	3	3	3	3	3	3	3	3	3	3	3	3	3	3	3	3	3	3	3	3	3	3	3	3	3	3	3	3	3	3	3	3	3	3	3	3	3		LABEL	
4	2202 2607 91		1	1	1	1	1	1	1	1	1	1	1	1	1	1	1	1	1	1	1	1	1	1	1	1	1	1	1	1	1	1	1	1	1	1	1	1	1	1	1	1	1	1	1	1		LABEL	
5	1088 1001 02		1	1	1	1	1	1	1	1	1	1	1	1	1	1	1	1	1	1	1	1	1	1	1	1	1	1	1	1	1	1	1	1	1	1	1	1	1	1	1	1	1	1	1	1		LABEL	
6	2202 8731 01					1	1	1					1	1	1	1	1	1	1	1					1	1	1														1	1	1	1	1	1		LABEL 1-PH	
7	2202 2512 93		1	1	1	1	1	1	1	1	1	1	1	1	1	1	1	1	1	1	1	1	1	1	1	1	1	1	1	1	1	1	1	1	1	1	1	1	1	1	1	1	1	1	1	1		LABEL OIL LEVEL	
8	2204 1818 13		1	1	1				1	1	1				1	1	1				1	1	1				1	1	1											1	1	1	1	1	1		LABEL SERVICE		
8	2204 1818 03					1	1	1					1	1	1				1	1	1				1	1	1													1	1	1	1	1	1		LABEL SERVICE		
9	2200 2607 91		1	1	1	1	1	1	1	1	1	1	1	1	1	1	1	1	1	1	1	1	1	1	1	1	1	1	1	1	1	1	1	1	1	1	1	1	1	1	1	1	1	1	1	1		LABEL AUTOMATIC START	
11	1079 9931 29		1	1	1	1	1	1	1	1	1	1	1	1	1	1	1	1	1	1	1	1	1	1	1	1	1	1	1	1	1	1	1	1	1	1	1	1	1	1	1	1	1	1	1	1		LABEL PURGE CONDENSATE	
12	2202 2607 91		1	1	1	1	1	1	1	1	1	1	1	1	1	1	1	1	1	1	1	1	1	1	1	1	1	1	1	1	1	1	1	1	1	1	1	1	1	1	1	1	1	1	1	1		LABEL	
13	2202 2042 89		1	1	1	1	1	1	1	1	1	1	1	1	1	1	1	1	1	1	1	1	1	1	1	1	1	1	1	1	1	1	1	1	1	1	1	1	1	1	1	1	1	1	1	1		LABEL	
14	2202 8731 00					1	1	1					1	1	1	1	1	1	1	1					1	1	1															1	1	1	1	1	1		LABEL 3-PH

TAB. 13

Targhette / Labels / Plaque / Schild / Placa

Q.tà - Qty - Q.té - Anz. - Cant.

HP 20 / kW 15 (230/50Hz - 400/50 Hz - 230/60Hz - 380-440/60Hz)

DESCRIZIONE - DESCRIPTION - DESIGNATION -  
BESCHREIBUNG - DESIGNACION

Rif. N. Ref. No Nr. Rêf. Bild Nr. Rif. N.	N. ordinaz. Part. num. Nr. Pièce Teil num. Codigo	Note-Note- Ann.-Nota	4152 0252 80	4152 0252 81	4152 0252 82	4152 0252 86	4152 0252 87	4152 0252 88	4152 0252 62	4152 0252 63	4152 0252 64	4152 0252 68	4152 0252 69	4152 0252 70	4152 0253 22	4152 0253 23	4152 0253 24	4152 0253 28	4152 0253 29	4152 0253 30	4152 0253 40	4152 0253 41	4152 0253 42	4152 0253 46	4152 0253 47	4152 0253 48	4152 0252 83	4152 0252 84	4152 0252 85	4152 0252 98	4152 0252 99	4152 0253 00	4152 0252 89	4152 0252 90	4152 0252 91	4152 0253 01	4152 0253 02	4152 0253 03	4152 0252 65	4152 0252 66	4152 0252 67	4152 0252 71	4152 0252 72	4152 0252 73								
1	2202 2607 91		4	4	4	4	4	4	4	4	4	4	4	4	4	4	4	4	4	4	4	4	4	4	4	4	4	4	4	4	4	4	4	4	4	4	4	4	4	4	4	4	4	4	4	4	4	4				
2	2202 2607 91		3	3	3	3	3	3	3	3	3	3	3	3	3	3	3	3	3	3	3	3	3	3	3	3	3	3	3	3	3	3	3	3	3	3	3	3	3	3	3	3	3	3	3	3	3	3	3			
3	2202 2607 91		3	3	3	3	3	3	3	3	3	3	3	3	3	3	3	3	3	3	3	3	3	3	3	3	3	3	3	3	3	3	3	3	3	3	3	3	3	3	3	3	3	3	3	3	3	3	3	3		
4	2202 2607 91		1	1	1	1	1	1	1	1	1	1	1	1	1	1	1	1	1	1	1	1	1	1	1	1	1	1	1	1	1	1	1	1	1	1	1	1	1	1	1	1	1	1	1	1	1	1	1	1		
5	1088 1001 02		1	1	1	1	1	1	1	1	1	1	1	1	1	1	1	1	1	1	1	1	1	1	1	1	1	1	1	1	1	1	1	1	1	1	1	1	1	1	1	1	1	1	1	1	1	1	1	1		
6	2202 8731 01		1	1	1	1	1	1					1	1	1			1	1	1	1	1	1	1	1	1	1	1	1	1	1	1	1	1	1	1	1	1	1	1	1	1	1	1	1	1	1	1	1			
7	2202 2512 93		1	1	1	1	1	1	1	1	1	1	1	1	1	1	1	1	1	1	1	1	1	1	1	1	1	1	1	1	1	1	1	1	1	1	1	1	1	1	1	1	1	1	1	1	1	1	1	1		
8	2204 1818 14		1	1	1				1	1	1				1	1	1				1	1	1				1	1	1	1	1	1	1	1	1	1	1	1	1	1		1	1	1	1	1	1	1	1			
8	2204 1818 04					1	1	1				1	1	1			1	1	1				1	1	1			1	1	1	1	1	1	1	1	1	1	1	1	1		1	1	1	1	1	1	1	1	1		
9	2200 2607 91		1	1	1	1	1	1	1	1	1	1	1	1	1	1	1	1	1	1	1	1	1	1	1	1	1	1	1	1	1	1	1	1	1	1	1	1	1	1	1	1	1	1	1	1	1	1	1	1	1	1
11	1079 9931 29		1	1	1	1	1	1	1	1	1	1	1	1	1	1	1	1	1	1	1	1	1	1	1	1	1	1	1	1	1	1	1	1	1	1	1	1	1	1	1	1	1	1	1	1	1	1	1	1	1	1
12	2202 2607 91		1	1	1	1	1	1	1	1	1	1	1	1	1	1	1	1	1	1	1	1	1	1	1	1	1	1	1	1	1	1	1	1	1	1	1	1	1	1	1	1	1	1	1	1	1	1	1	1	1	1
13	2202 2042 89		1	1	1	1	1	1	1	1	1	1	1	1	1	1	1	1	1	1	1	1	1	1	1	1	1	1	1	1	1	1	1	1	1	1	1	1	1	1	1	1	1	1	1	1	1	1	1	1	1	1
14	2202 8731 00		1	1	1	1	1	1				1	1	1			1	1	1	1	1	1	1	1	1	1	1	1	1	1	1	1	1	1	1	1	1	1	1	1	1	1	1	1	1	1	1	1	1	1	1	1

**TAB. 13**

Targhette / Labels / Plaque / Schild / Placa

Q.tà - Qty - Q.té - Anz. - Cant.

HP 20 / kW 15 (230/50Hz - 400/50 Hz - 230/60Hz - 380-440/60Hz)

DESCRIZIONE - DESCRIPTION - DESIGNATION -  
BESCHREIBUNG - DESIGNACION

Rif. N. Ref. No Nr. Réf. Bild Nr. Rif. N.	N. ordinaz. Part. num. Nr. Pièce Teil num. Codigo	Note-Note-Note- Ann.-Nota	4152 0253 25	4152 0253 26	4152 0253 27	4152 0253 31	4152 0253 32	4152 0253 33	4152 0253 43	4152 0253 44	4152 0253 45	4152 0253 49	4152 0253 50	4152 0253 51	4152 0253 10	4152 0253 11	4152 0253 12	4152 0253 13	4152 0253 14	4152 0253 15	4152 0252 74	4152 0252 75	4152 0252 76	4152 0252 77	4152 0252 78	4152 0252 79	4152 0252 56	4152 0252 57	4152 0252 58	4152 0252 59	4152 0252 60	4152 0252 61	4152 0253 16	4152 0253 17	4152 0253 18	4152 0253 19	4152 0253 20	4152 0253 21	4152 0253 34	4152 0253 35	4152 0253 36	4152 0253 37	4152 0253 38	4152 0253 39																
1	2202 2607 91		4	4	4	4	4	4	4	4	4	4	4	4	4	4	4	4	4	4	4	4	4	4	4	4	4	4	4	4	4	4	4	4	4	4	4	4	4	4	4	4	4	4	4	4	4	4	4	4	4	4								
2	2202 2607 91		3	3	3	3	3	3	3	3	3	3	3	3	3	3	3	3	3	3	3	3	3	3	3	3	3	3	3	3	3	3	3	3	3	3	3	3	3	3	3	3	3	3	3	3	3	3	3	3	3	3	3							
3	2202 2607 91		3	3	3	3	3	3	3	3	3	3	3	3	3	3	3	3	3	3	3	3	3	3	3	3	3	3	3	3	3	3	3	3	3	3	3	3	3	3	3	3	3	3	3	3	3	3	3	3	3	3	3	3						
4	2202 2607 91		1	1	1	1	1	1	1	1	1	1	1	1	1	1	1	1	1	1	1	1	1	1	1	1	1	1	1	1	1	1	1	1	1	1	1	1	1	1	1	1	1	1	1	1	1	1	1	1	1	1	1	1						
5	1088 1001 02		1	1	1	1	1	1	1	1	1	1	1	1	1	1	1	1	1	1	1	1	1	1	1	1	1	1	1	1	1	1	1	1	1	1	1	1	1	1	1	1	1	1	1	1	1	1	1	1	1	1	1	1						
6	2202 8731 01								1	1	1	1	1	1	1	1	1	1	1	1	1	1	1	1	1	1	1	1	1	1	1	1	1	1	1	1	1	1	1	1	1	1	1	1	1	1	1	1	1	1	1	1	1	1						
7	2202 2512 93		1	1	1	1	1	1	1	1	1	1	1	1	1	1	1	1	1	1	1	1	1	1	1	1	1	1	1	1	1	1	1	1	1	1	1	1	1	1	1	1	1	1	1	1	1	1	1	1	1	1	1	1						
8	2204 1818 14		1	1	1				1	1	1				1	1	1				1	1	1					1	1	1												1	1	1	1	1	1	1	1	1	1	1	1	1						
8	2204 1818 04					1	1	1				1	1	1					1	1	1				1	1	1																1	1	1	1	1	1	1	1	1	1	1	1	1					
9	2200 2607 91		1	1	1	1	1	1	1	1	1	1	1	1	1	1	1	1	1	1	1	1	1	1	1	1	1	1	1	1	1	1	1	1	1	1	1	1	1	1	1	1	1	1	1	1	1	1	1	1	1	1	1	1	1	1				
11	1079 9931 29		1	1	1	1	1	1	1	1	1	1	1	1	1	1	1	1	1	1	1	1	1	1	1	1	1	1	1	1	1	1	1	1	1	1	1	1	1	1	1	1	1	1	1	1	1	1	1	1	1	1	1	1	1	1	1			
12	2202 2607 91		1	1	1	1	1	1	1	1	1	1	1	1	1	1	1	1	1	1	1	1	1	1	1	1	1	1	1	1	1	1	1	1	1	1	1	1	1	1	1	1	1	1	1	1	1	1	1	1	1	1	1	1	1	1	1	1		
13	2202 2042 89		1	1	1	1	1	1	1	1	1	1	1	1	1	1	1	1	1	1	1	1	1	1	1	1	1	1	1	1	1	1	1	1	1	1	1	1	1	1	1	1	1	1	1	1	1	1	1	1	1	1	1	1	1	1	1	1	1	
14	2202 8731 00								1	1	1	1	1	1	1	1	1	1	1	1	1	1	1	1	1	1	1	1	1	1	1	1	1	1	1	1	1	1	1	1	1	1	1	1	1	1	1	1	1	1	1	1	1	1	1	1	1	1	1	1

WARNING LABEL
LABEL
LABEL
LABEL
LABEL
LABEL
LABEL 1-PH
LABEL OIL LEVEL
LABEL SERVICE
LABEL SERVICE
LABEL AUTOMATIC START
LABEL PURGE CONDENSATE
LABEL
LABEL
LABEL 3-PH



**TAB. 14**

KIT DI MANUTENZIONE / SERVICE KIT / KIT DE MAINTENANCE / WARTUNGSAUFBAUSATZ / KIT DE MANTENIMIENTO	
<b>Kit</b> Valvola termostatica / Thermostatic valve / Valve thermostatique / Thermostatisches Ventil / Válvula termostática )	
Codice / Code / Codice / Kode / Código	<b>CPA HP 7,5 - 10 - 15 - 20 / kW 5,5 - 7,5 - 11 - 15</b>
<b>2901 1095 00</b>	
<b>Kit</b> Valvola di scarico / Unloading valve / Soupape de décharge / Entlastungsventil / Válvula de descarga )	
Codice / Code / Codice / Kode / Código	<b>CPA HP 7,5 - 10 - 15 - 20 / kW 5,5 - 7,5 - 11 - 15</b>
<b>2901 0298 01</b>	
<b>Kit 2000</b> ( Ore / Hours / Heures / Betriebsstunden / Horas de servicio )	
Codice / Code / Codice / Kode / Código	<b>CPA ( HP 7,5 - 10 - 15 / kW 5,5 - 7,5 - 11 )</b> <i>Con essiccatore - With dryer - Avec sécheur - Mit Trokner - Con secador</i>
<b>2200 9032 66</b>	
<b>Kit 4000</b> ( Ore / Hours / Heures / Betriebsstunden / Horas de servicio )	
Codice / Code / Codice / Kode / Código	<b>CPA ( HP 7,5 - 10 - 15 / kW 5,5 - 7,5 - 11 )</b> <i>Con essiccatore - With dryer - Avec sécheur - Mit Trokner - Con secador</i>
<b>2200 9032 67</b>	
<b>Kit 2000</b> ( Ore / Hours / Heures / Betriebsstunden / Horas de servicio )	
Codice / Code / Codice / Kode / Código	<b>CPA ( HP 7,5 - 10 - 15 / kW 5,5 - 7,5 - 11 )</b>
<b>2200 9032 83</b>	
<b>Kit 4000</b> ( Ore / Hours / Heures / Betriebsstunden / Horas de servicio )	
Codice / Code / Codice / Kode / Código	<b>CPA ( HP 7,5 - 10 - 15 / kW 5,5 - 7,5 - 11 )</b>
<b>2200 9025 93</b>	
<b>Kit 8000</b> ( Ore / Hours / Heures / Betriebsstunden / Horas de servicio )	
Codice / Code / Codice / Kode / Código	<b>CPA ( HP 7,5 - 10 - 15 / kW 5,5 - 7,5 - 11 )</b> <i>Con essiccatore - With dryer - Avec sécheur - Mit Trokner - Con secador</i>
<b>2200 9032 81</b>	
<b>Kit 8000</b> ( Ore / Hours / Heures / Betriebsstunden / Horas de servicio )	
Codice / Code / Codice / Kode / Código	<b>CPA ( HP 7,5 - 10 - 15 / kW 5,5 - 7,5 - 11 )</b>
<b>2200 9032 70</b>	

**TAB. 14**

**KIT DI MANUTENZIONE / SERVICE KIT / KIT DE MAINTENANCE / WARTUNGSAUFBAUSATZ / KIT DE MANTENIMIENTO**

<b>Kit</b> <i>Valvola termostatica / Thermostatic valve / Valve thermostatique / Thermostatisches Ventil / Válvula termostática</i>	
Codice / Code / Codice / Kode / Código	<b>CPA HP 7,5 - 10 - 15 - 20 / kW 5,5 - 7,5 - 11 - 15</b>
<b>2901 1095 00</b>	

<b>Kit</b> <i>Valvola di scarico / Unloading valve / Soupape de décharge / Entlastungsventil / Válvula de descarga</i>	
Codice / Code / Codice / Kode / Código	<b>CPA HP 7,5 - 10 - 15 - 20 / kW 5,5 - 7,5 - 11 - 15</b>
<b>2901 0298 01</b>	

<b>Kit 2000</b> ( Ore / Hours / Heures / Betriebsstunden / Horas de servicio )	
Codice / Code / Codice / Kode / Código	<b>CPA ( HP 20 - kW 15 )</b> <i>Con essiccatore - With dryer - Avec sécheur - Mit Trokner - Con secador</i>
<b>2200 9032 68</b>	

<b>Kit 4000</b> ( Ore / Hours / Heures / Betriebsstunden / Horas de servicio )	
Codice / Code / Codice / Kode / Código	<b>CPA ( HP 20 - kW 15 )</b> <i>Con essiccatore - With dryer - Avec sécheur - Mit Trokner - Con secador</i>
<b>2200 9032 69</b>	

<b>Kit 2000</b> ( Ore / Hours / Heures / Betriebsstunden / Horas de servicio )	
Codice / Code / Codice / Kode / Código	<b>CPA ( HP 20 - kW 15 )</b>
<b>2200 9032 84</b>	

<b>Kit 4000</b> ( Ore / Hours / Heures / Betriebsstunden / Horas de servicio )	
Codice / Code / Codice / Kode / Código	<b>CPA ( HP 20 - kW 15 )</b>
<b>2200 9025 95</b>	

<b>Kit 8000</b> ( Ore / Hours / Heures / Betriebsstunden / Horas de servicio )	
Codice / Code / Codice / Kode / Código	<b>CPA ( HP 20 - kW 15 )</b> <i>Con essiccatore - With dryer - Avec sécheur - Mit Trokner - Con secador</i>
<b>2200 9032 82</b>	

<b>Kit 8000</b> ( Ore / Hours / Heures / Betriebsstunden / Horas de servicio )	
Codice / Code / Codice / Kode / Código	<b>CPA ( HP 20 - kW 15 )</b>
<b>2200 9032 71</b>	

<b>Tabella olio / Tab. oil / Tab. huile / Abb. Öl / Tab. aceite</b>	
<b>Rotair</b>	
<b>5 L</b>	<b>6215 7140 00</b>
<b>20 L</b>	<b>6215 7141 00</b>
<b>209 L</b>	<b>6215 7142 00</b>

<b>Rotair FOOD GRADE (Option)</b>	
<b>5 L</b>	<b>1630 0821 00</b>
<b>20 L</b>	<b>1630 0605 00</b>

<b>Rotair Xtra (Option 8000 Hrs Oil)</b>	
<b>5 L</b>	<b>6215 7148 00</b>
<b>20 L</b>	<b>6215 7149 00</b>
<b>209 L</b>	<b>6215 7150 00</b>

**Tabella cingie / Tab. driving belt / Tab. courroie / Abb. Treibriemen / Tab. correa trasmisora**

HP / kW	bar / psi	50 Hz		60 Hz					
		Codice / Code / Code / Kode / Codigo	Q.tà Q.ty Q.té Anz. Cant.	Codice / Code / Code / Kode / Codigo	Q.tà Q.ty Q.té Anz. Cant.				
<b>CPA 5,5 7,5 / 5,5</b>	8	<b>2204 1556 54</b>	<b>1</b>	<b>2204 1556 53</b>	<b>1</b>				
	10	<b>2204 1556 54</b>	<b>1</b>	<b>2204 1556 54</b>	<b>1</b>				
	13								
<b>CPA 7,5 10 / 7,5</b>	8	<b>2204 1556 58</b>	<b>1</b>	<b>2204 1556 57</b>	<b>1</b>				
	10	<b>2204 1556 57</b>	<b>1</b>	<b>2204 1556 56</b>	<b>1</b>				
	13	<b>2204 1556 56</b>	<b>1</b>	<b>2204 1556 55</b>	<b>1</b>				
<b>CPA 11 15 / 11</b>	8	<b>2204 1556 58</b>	<b>1</b>	<b>2204 1556 57</b>	<b>1</b>				
	10	<b>2204 1556 58</b>	<b>1</b>	<b>2204 1556 57</b>	<b>1</b>				
	13	<b>2204 1556 58</b>	<b>1</b>	<b>2204 1556 57</b>	<b>1</b>				
<b>CPA 15 20 / 15</b>	8	<b>2200 6605 26</b>	<b>2</b>	<b>2200 6605 26</b>	<b>2</b>				
	10	<b>2200 6604 06</b>	<b>2</b>	<b>2200 6605 25</b>	<b>2</b>				
	13	<b>2200 6605 25</b>	<b>2</b>	<b>2200 6605 25</b>	<b>2</b>				

